

EOSW-100 Series RF Wall Switches

Single and dual relay
120/277 VAC RF-enabled
switches

Replace standard wall switches
for energy code compliance
without the need for rewiring



Receiver for wireless
communication with RF occupancy
sensors and remote switches

Default settings for most energy efficient
operating mode out of the box

Loads can be assigned to either
button (dual relay switches)

PROJECT
LOCATION/TYPE

Product Overview

Description

EOSW-100 Series RF Wall Switches work with EOPC-100 wireless occupancy sensors, and optional EORS-100 and EOHR-100 remote switches, to turn lights on and off based on occupancy. Models are available to control one or two switched legs in applications with or without neutral wires at the switch box.

Operation

Both single and dual relay RF wall switches fit in single gang junction boxes for direct control of one or two loads. Each wall switch can be paired with one or more EOPC-100 wireless sensors for occupancy-based control. By default, single relay wall switches operate in manual-on/automatic-off mode. Dual relay switches are factory set for auto-on to 50%; relay 1 is automatic on/off, and relay 2 is manual-on/automatic-off. When occupancy is no longer detected and the time delay elapses, lights automatically turn off. These sequences of operation, and other default settings, may be changed using hidden configuration buttons.

Control Options and RF Communications

EOSW-100 RF dual relay switches allow for separate pairing of each controlled load (relay) to the integral switch buttons. Additionally, each load may be paired with selected wireless occupancy sensors and selected buttons on RF remote switches. The RF transmission range is approximately 50' to 150' depending on product placement.

Applications

RF wall switches are ideal for retrofit applications with or without neutral wires where the switch location is not suitable for sensing occupancy, and it is difficult to install a wired ceiling sensor. Paired with wireless occupancy sensors, EOSW-100 RF switches are perfect for retrofitting small conference rooms, private offices, executives office, hallways and storage rooms.

Features

- RF wall switches work with EOPC-100 wireless occupancy sensors
- Zero-crossing for long relay life
- Choice of manual-on or auto-on operation
- EOSW-111 and EOSW-112 comply with 2011 NEC requirements
- Selectable time delay
- Test mode allows quick and easy set up
- Compatible with decorator wall plates



Specifications

- 120/277VAC; 60 Hz
- Load rating, per relay:
 - Ⓢ 120VAC, 800W ballast, LED driver, ELV, MLV or tungsten, or 1/6hp motor (EOSW-10x, 15W minimum for load 1)
 - Ⓢ 277VAC, 1200W ballast, LED driver, ELV or MLV (EOSW-10x, 30W minimum for load 1)
- Relay Type: Form A latching relay
- 1 or 2 load buttons, each with LED status indicator
- Time Delays: 5, 15, 30 minutes (default 15 min.)
- Memory: Stores up to 10 transmitter IDs
- Frequency: 902MHz, integrated whip antenna
- Operating conditions: for indoor use only; 5-95% RH, non condensing
- Operating temperature: EOSW-10x: 32-104°F (0-40°C); EOSW-11x: 32-131°F (0-55°C)
- UL and cUL listed
- FCC part 15 compliant
- Five year warranty

Controls & Settings

Product Dimensions and Controls

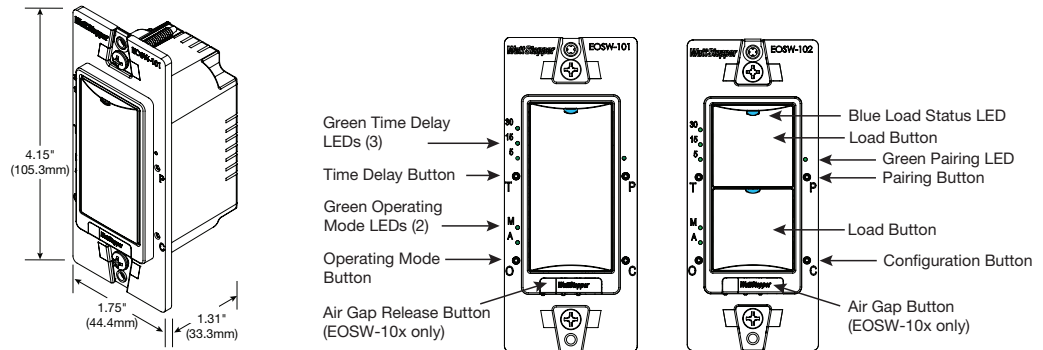

Wiring Diagrams

Dual relay switch, no neutral

Dual relay switch, with neutral wire

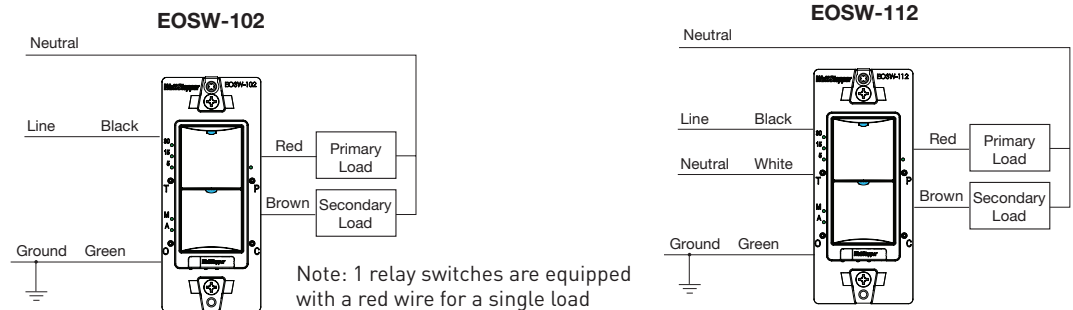

Ordering Information

Catalog No.	Color	Description	Voltage	Load Rating, per relay
<input type="checkbox"/> EOSW-101-W	White	Single relay RF wall switch, no neutral	120/277 VAC; 60 Hz	Load 1: Ⓢ 120VAC, 15-800W or 1/6hp Ⓢ 277VAC, 30-1200W
<input type="checkbox"/> EOSW-101-LA	Lt. Almond			
<input type="checkbox"/> EOSW-101-I	Ivory			
<input type="checkbox"/> EOSW-101-G	Grey			
<input type="checkbox"/> EOSW-101-B	Black	Dual relay RF wall switch, no neutral		Load 2: Ⓢ 120VAC, 0-800W or 1/6hp Ⓢ 277VAC, 0-1200W
<input type="checkbox"/> EOSW-102-W	White			
<input type="checkbox"/> EOSW-102-LA	Lt. Almond			
<input type="checkbox"/> EOSW-102-I	Ivory			
<input type="checkbox"/> EOSW-102-G	Grey	Single relay RF wall switch, with neutral		Loads 1 & 2: Ⓢ 120VAC, 0-800W or 1/6hp Ⓢ 277VAC, 0-1200W
<input type="checkbox"/> EOSW-102-B	Black			
<input type="checkbox"/> EOSW-111-W	White			
<input type="checkbox"/> EOSW-111-LA	Lt. Almond			
<input type="checkbox"/> EOSW-111-I	Ivory	Dual relay RF wall switch, with neutral		
<input type="checkbox"/> EOSW-111-G	Grey			
<input type="checkbox"/> EOSW-111-B	Black			
<input type="checkbox"/> EOSW-112-W	White			
<input type="checkbox"/> EOSW-112-LA	Lt. Almond			
<input type="checkbox"/> EOSW-112-I	Ivory			
<input type="checkbox"/> EOSW-112-G	Grey			
<input type="checkbox"/> EOSW-112-B	Black			

Order wall plate separately.