



# Markel

Products Company

[www.markel-products.com](http://www.markel-products.com)

THE CHOICE OF PROFESSIONALS SINCE 1921

HEATERS

CONTROLS



Scan & View On Your  
Smartphone Or Portable Device.  
(PDF File)



[www.facebook.com/tpicorporation](http://www.facebook.com/tpicorporation)



[@tpicorporation](https://twitter.com/tpicorporation)

PH: 1-800-682-3398 / 1-423-477-4131 | FAX: 1-423-477-0064

ELECTRIC HEAT, CONTROLS, & THERMOSTATS

INDUSTRIAL - COMMERCIAL - RESIDENTIAL

© Copyright 2014; TPI Corporation, P.O. Box 4973, Johnson City, TN 37602  
January 1, 2014; Distribution Products Catalog Revision: 010114-001

**CATEGORY** **Page**

AMPERAGE CHART & WARRANTY	2
ELECTRIC HEAT COMFORT ZONES	3

**HAZARDOUS LOCATION & WASHDOWN**

HLA*	Hazardous Location Fan Forced	4-7
PHLA*	Portable Hazardous Location Fan Forced	7
FEP*	Hazardous Location Convactor	8-9
5500*	Washdown Fan Forced	10-11

**UNIT HEATERS**

UH	Horizontal Fan Forced	12-13
5100	Horizontal or Vertical Fan Forced	14-19
2600	Downflow Fan Forced	20-22
5700	Confined Space Plenum Rated	22
5600	Multiple Wattage Fan Forced	23
6300	Cabinet Fan Forced	24-27

**WALL CONVECTORS**

8500*	Commercial Slope Top	28-29
8800*	Institutional	30-31
4100*	Recessed Commercial	32-33

**CEILING & COVE**

3000	Fan Forced	34
3380	Commercial Fan Forced	34
3480*	Commercial Recessed Fan Forced	35
3470*	Commercial Surface Fan Forced	36
CP/RCP	Radiant Ceiling Panel	37
CVX	Radiant Cove	38

**WALL HEATERS**

3000	Commercial Midsized Fan Forced	39
3320	Commercial Fan Forced	40
4400	Commercial Low Profile Fan Forced	40
3420/50	Heavy Duty Fan Forced	41-43
3310	Residential/Commercial Fan Forced	44-45
3200	Midsized Fan Forced	46
4300	Low Profile Fan Forced	47
4800	Register Style Fan Forced	48

**BASEBOARD HEATERS**

3900	Hydronic Electric	49
3700	Architectural Style Electric	50
	Hydronic/Architectural Accessories	51
2900HA	High Altitude Electric	52
2900S	Stainless Steel Element Electric	53
2900C	Heavy Duty Commercial Electric	54
	Electric Baseboard Accessories	55

**ARCHITECTURAL SILL LINE**

9100*	Radius Front Draft Barrier	56-57
9300*	Radius Front Draft Barrier	58-59
	General Product Information	60
DBT/DBT*	3-1/8" x 4-1/2" Convactor	61
DBCT/DBCF*	3-1/2" x 6" Convactor	61
DBTS*	2-5/8" x 4" Convactor	62
RDBT*	7" x 6" Convactor (Round)	63
CB*	2-5/8" x 4-1/2" Convactor	63
ASHDB*	5-1/2" x 8" thru 20" Tall Convactor	63

*\*Products listed in this section are custom built and subject to 100% cancellation/restocking charges*

Note: The information contained herein is deemed to be as accurate as possible upon the time of printing. However, to insure that you receive the most reliable information contact the factory should a question arise. All prices are given in U.S. Dollar Amounts.

PH: 1-800-682-3398. © Copyright 2012; TPI Corporation.

**CATEGORY** **Page**

**ELECTRIC INFRARED HEATERS**

MR	Heavy Duty Metal Sheath	64-65
TH & THSS	Mul-T-Mount	66-69
OCH	Outdoor/Indoor Rated Quartz	70-71
CH	Indoor/Semi-Protected Rated Quartz	71
RPH	Outdoor Rated Stainless Steel	72
MM	Mitey Midget	72
FFH	Utility Elements, Accessories, & Controls	73-75
FHK	Heavy Duty Metal Sheath Infrared	76
CH	120/240V Quartz Infrared	77
PCH	Portable Quartz Infrared Spot Heater	77
RHG	Portable Infrared Instant "On-Off" Heat Gun	77
HP	Portable Electric Infrared Heat Panels	77

**PORTABLE HEATERS**

FES & YES	Salamander Heat WaveTM	78
198	120V Fan Glo	79
178	120V Ceramic	79
188	120V Milk House	79
170-TS	120V Confined Space	79
483	120V Baseboard	79
474	240V Dual Heat Fan Forced	80
5800	240V Garage/Workshop	80
ICH	240V Construction/Utility	80
680	240V Heavy Duty	80

**SPECIALTY HEATERS**

RPH	Pump House	81
FH	In-Floor Fan Forced	81
TSH	Kick-Space Fan Forced	81

**AIR CURTAIN**

CF/CFH*	Variable Speed Air Curtain	82
---------	----------------------------	----

**THERMOSTATS**

SD	Setback On Demand	82
ET	Line Voltage, 22A, 120-277VAC	83
EPET / HLT	Line Voltage, Haz. Loc., 120-277VAC	83
2000	Line Voltage, 22A, 120-277VAC	83
TW	Line Voltage, 120-277VAC	84
KT	Line Voltage, 120-250VAC	84
L	Line Voltage, 25A Resistive, SPDT H/C	84
H	Humidistat/DeHumidistat, 24-240VAC	85
T	Line Voltage, Precision, 120-277VAC	85
TL	Line Voltage, Programmable	85
RF	Low Voltage, Wireless	85
TH	Low Voltage, Programmable	86
TW	Low Voltage, 2 Stage	86
A	Low Voltage, Round	86
UT	Low Voltage, Vertical/Horizontal Mnt.	87
RK	Low Voltage, Square	87
24A	Low Voltage Relays	87
TG	Thermostat Guards	87

**THERMAL AREA TREATMENT**

TAT*	Area Treatment - Pest Remediation	88-90
------	-----------------------------------	-------

**DUCT HEATERS**

HP*	HotPod Resi. Supplemental Duct Heat	91-92
7200/7300*	Plenum Heaters	93-96
PD*	Packaged (preconfigured) Duct Heat	97
CHMS*	Enclosed Finned Tubular Element	98
HF*	Open Coil Element	99-100
MFH*	Fan Coil Units	101-108

**PRODUCT INDEX**



# Amperage Chart & Electric Heat Products Limited Warranty

K.W Rating	B.T.U.H.	208 Volt AMP Rating		220 Volt AMP Rating		230 Volt AMP Rating		240 Volt AMP Rating		277 Volt AMP Rating	440 Volt AMP Rating	480 Volt AMP Rating	550 Volt AMP Rating
		1 PH	3 PH	1 PH	3 PH	1 PH	3 PH	1 PH	3 PH	1 PH	3 PH	3 PH	3 PH
00.5	1,706	2.4	1.4	2.3	1.3	2.2	1.3	2.1	1.2	1.8	0.6	0.6	0.5
01.0	3,413	4.8	2.8	4.5	2.6	4.3	2.5	4.2	2.4	3.6	1.3	1.2	1.0
02.0	6,826	9.6	5.5	9.1	5.2	8.7	5.0	8.3	4.8	7.2	2.6	2.4	2.1
03.0	10,239	14.4	8.3	13.6	7.9	13.0	7.5	12.5	7.2	10.8	3.9	3.6	3.1
04.0	13,652	19.2	11.1	18.2	10.4	17.5	10.1	16.6	9.6	14.4	5.2	4.8	4.2
05.0	17,065	24.0	13.8	22.7	13.1	21.7	12.6	20.8	12.0	18.1	6.6	6.0	5.2
06.0	20,478	28.8	16.6	27.3	15.7	26.1	15.1	25.0	14.4	21.7	7.9	7.2	6.3
07.0	23,891	33.6	19.4	31.8	18.4	30.4	17.6	29.1	16.8	25.3	9.2	8.4	7.3
08.0	27,304	38.5	22.2	36.4	20.9	34.9	20.1	33.3	19.2	28.9	10.5	9.6	8.4
09.0	30,717	42.8	24.9	40.9	23.3	39.1	22.6	37.7	21.4	32.5	11.8	10.8	9.5
10.0	34,130	48.1	27.4	45.4	26.2	43.5	25.1	41.7	24.0	36.1	13.2	12.0	10.5
11.0	37,543	52.9	30.5	50.0	28.6	47.8	27.6	45.8	26.4	39.7	14.5	13.2	11.6
12.0	40,956	57.7	33.2	54.5	31.5	52.1	30.2	50.0	28.6	43.3	15.8	14.4	12.6
13.0	44,369	62.5	36.0	59.1	34.1	56.9	32.7	54.2	31.3	46.9	17.1	15.6	13.7
14.0	47,782	67.3	38.8	63.6	36.7	60.9	35.2	58.3	33.7	50.5	18.4	16.8	14.7
15.0	51,195	72.1	41.5	68.2	39.1	65.2	37.7	62.5	35.1	54.2	19.8	18.0	15.8
16.0	54,608	76.9	44.3	72.7	41.9	69.6	40.2	66.7	38.5	57.8	21.1	19.2	16.9
17.0	58,021	81.7	47.1	77.3	44.3	73.9	42.7	70.8	40.9	61.4	22.4	20.4	17.9
18.0	61,434	86.5	49.8	81.8	47.2	78.3	45.2	75.0	43.3	65.0	23.7	21.6	19.0
19.0	64,847	91.3	52.6	86.4	49.6	82.6	47.7	79.2	45.7	68.6	25.1	22.8	20.0
20.0	68,260	96.1	55.1	90.9	52.5	86.9	50.3	83.3	48.1	72.2	26.4	24.0	21.1
21.0	71,673	100.0	58.2	95.6	55.1	91.3	52.9	87.5	50.5	75.8	27.7	25.2	22.1
22.0	75,086	105.8	60.9	100.0	57.7	95.7	55.3	91.7	52.9	79.4	29.0	26.4	23.1
23.0	78,499	110.6	63.7	104.5	60.4	100.0	57.9	95.8	55.3	83.0	30.3	27.6	24.3
24.0	81,912	115.4	66.5	109.1	62.9	104.3	60.3	100.0	57.7	86.6	31.7	28.8	25.3
25.0	85,325	120.2	69.2	113.6	65.3	108.6	62.8	104.1	60.1	90.3	33.0	30.1	26.4
26.0	88,738	125.0	72.0	118.2	68.3	113.0	65.3	108.3	62.5	93.9	34.3	31.3	27.4
27.0	92,151	129.8	74.8	122.7	70.9	117.4	67.8	112.5	64.7	97.5	35.6	32.5	28.5
28.0	95,564	134.6	77.2	128.2	73.5	121.7	70.3	116.6	67.3	101.1	36.9	33.7	29.5
29.0	98,977	139.4	80.3	131.8	76.0	126.0	72.9	120.8	69.7	104.7	38.3	34.9	30.6
30.0	102,390	144.2	83.1	136.4	78.7	130.4	75.4	125.0	72.1	108.3	39.6	36.1	31.7
31.0	105,803	149.0	85.9	140.9	81.3	134.7	77.9	129.2	74.5	111.9	40.9	37.3	32.7
32.0	109,216	153.8	88.7	145.4	83.9	139.0	80.4	133.4	76.9	115.5	42.2	38.5	33.8
33.0	112,629	158.6	91.5	149.9	86.5	143.3	82.9	137.6	79.3	119.1	43.5	39.7	34.8
34.0	116,042	163.4	94.3	154.4	89.1	147.6	85.4	141.8	81.7	122.7	44.8	40.9	35.9
35.0	119,455	168.2	97.1	158.9	91.7	151.9	87.9	146.0	84.1	126.4	46.1	42.1	36.9
36.0	122,868	173.0	99.9	163.4	94.3	156.2	90.4	150.2	86.5	130.0	47.4	43.3	38.0
37.0	126,281	177.8	102.7	167.9	96.9	160.5	92.9	154.4	88.9	133.6	48.7	44.5	39.0
38.0	129,694	182.6	105.5	172.4	99.5	164.8	95.4	158.6	91.3	137.2	50.0	45.7	40.1
39.0	133,107	187.4	108.3	176.9	102.1	169.1	97.9	162.8	93.7	140.7	51.3	46.9	41.1
40.0	136,520	192.2	111.1	181.4	104.7	173.4	100.4	167.0	96.1	144.4	52.6	48.1	42.2
41.0	139,933	197.0	113.9	185.9	107.3	177.7	102.9	171.2	98.5	148.0	53.9	49.3	43.2
42.0	143,346	201.8	116.7	190.4	109.9	182.0	105.4	175.4	100.9	151.6	55.2	50.6	44.3
43.0	146,759	206.6	119.5	194.9	112.5	186.3	107.9	179.6	103.3	155.2	56.5	51.8	45.3
44.0	150,172	211.4	122.3	199.4	115.1	190.6	110.4	183.8	105.7	158.8	57.8	53.0	46.4
45.0	153,585	216.2	125.1	203.9	117.7	194.9	112.9	188.0	108.1	162.5	59.1	54.2	47.4
46.0	156,998	221.0	127.9	208.4	120.3	199.2	115.4	192.2	110.5	166.1	60.4	55.4	48.5
47.0	160,411	225.8	130.7	212.9	122.9	203.5	117.9	196.4	112.9	169.7	61.7	56.6	49.5
48.0	163,824	230.6	133.5	217.4	125.5	207.8	120.4	200.6	115.3	173.3	63.0	57.8	50.6
49.0	167,237	235.4	136.3	221.9	128.1	212.1	122.9	204.8	117.7	176.9	64.3	59.0	51.6
50.0	170,650	240.2	139.1	226.4	130.7	216.4	125.4	209.0	120.1	180.5	65.6	60.2	52.7
51.0	174,063	245.0	141.9	230.9	133.3	220.7	127.9	213.2	122.5	184.1	66.9	61.4	53.7
52.0	177,476	249.8	144.7	235.4	135.9	225.0	130.4	217.4	124.9	187.7	68.2	62.6	54.8
53.0	180,889	254.6	147.5	239.9	138.5	229.3	132.9	221.6	127.3	191.3	69.5	63.8	55.8
54.0	184,302	259.4	150.3	244.4	141.1	233.6	135.4	225.8	129.7	194.9	70.8	65.0	56.9
55.0	187,715	264.2	153.1	248.9	143.7	237.9	137.9	230.0	132.1	198.6	72.2	66.2	57.9
56.0	191,128	269.0	155.9	253.4	146.3	242.2	140.4	234.2	134.5	202.2	73.5	67.4	58.9
57.0	194,541	273.8	158.7	257.9	148.9	246.5	142.9	238.4	136.9	205.8	74.9	68.6	59.9
58.0	197,954	278.6	161.5	262.4	151.5	250.8	145.4	242.6	139.3	209.4	76.2	69.8	60.9
59.0	201,367	283.4	164.3	266.9	154.1	255.1	147.9	246.8	141.7	213.0	77.5	71.0	62.3
60.0	204,780	288.2	167.1	271.4	156.7	259.4	150.4	251.0	144.1	216.6	78.8	72.2	63.0

Note: All custom built products are subject to 100% cancellation/ restock charges.

Heat Products	
198 Series Elements	1 Year
Elements in Baseboard	10 Years
All Other Heating Products	1 Year
Thermostats & Controls	2 Years

**TPI UPC NUMBER IS REQUIRED FOR ALL ORDERS PLACED**  
**686334 X X X X X X**

UPC #	MODEL	KW	BTU
686334			
739344	PHLA12-208160-3.0-24-TDP		
739337	PHLA12-208160-3.0-24-TDP		
739320	PHLA12-240160-3.0-24-TDP		
739313	PHLA12-240360-3.0-24-TDP		
739306	PHLA12-480360-3.0-24-TDP	3	10,250
739436	PHLA12-600360-3.0-24-TDP		

**IMPORTANT ORDERING POLICY**  
 When ordering any cataloged item the UPC number must be included with the order. This number must be the TPI Corporation UPC number and not the customer's item number. This policy applies to all orders including EDI orders.

Products manufactured by TPI Corporation are warranted to the original consumer to be free from defects in material and workmanship for twelve (12) months from the original date of purchase. The TPI warranty does not cover products modified outside our factory, damage or failure caused by acts of God, abuse, misuse, connected to or placed on other than rated voltage, abnormal usage, faulty installation, failure to follow suggested maintenance procedures enclosed with the product, improper maintenance or any repairs other than those provided by an authorized TPI Corporation service center.

There are no obligations or liabilities on the part of the corporation for consequential damages arising out of, or in connection with, the use or performance of the product, or other indirect damages with respect to loss of property, revenues, or profit, or costs of removal, installation or reinstallation.

All implied warranties with respect to TPI products, including implied warranties for merchantability and implied warranties for fitness, are limited in duration to twelve (12) months from original date of purchase, except those products or parts of products which are warranted for longer periods. On such products or parts of products all implied warranties for merchantability and fitness are limited to the duration of the extended warranty period thereon.

Some states do not allow the exclusion or limitation of incidental or consequential damages and some states do not allow limitations on how long an implied warranty lasts. The above exclusions or limitations may not apply to you.

During the warranty period, TPI Corporation will, at its sole option, repair or replace any defective parts or products returned, freight prepaid, to the TPI Corporation factory or such other location as TPI Corporation may designate. Returned products must be packaged carefully and TPI Corporation shall not be responsible for damage in transit. When returning parts, the owner must provide the model number of the product and nature of difficulty being experienced. This warranty does not obligate TPI Corporation to bear the cost of labor in replacing any assembly, unit or component part thereof, nor does the company assume any liability for secondary charges, expenses for installing or removal, freight or damages. There will be charges rendered for product repairs made after out warranty period has expired. Proof of purchase, including date, must accompany request for in-warranty service. In any event, TPI Corporation's maximum liability shall not in any case exceed the list price for the product claimed to be defective. This warranty gives to you specific legal rights and you may have other rights, which may vary, from state to state. For the name of you nearest authorized TPI Corporation service center, please write to TPI Corporation, P.O. Box 4973, Johnson City, Tennessee, 37602.

In addition to the Limited Warranty stated above covering general products, TPI Corporation extends this warranty on the following listed products, which are warranted to the original consumer from the original date of purchase for the total time periods indicated herein to the left:

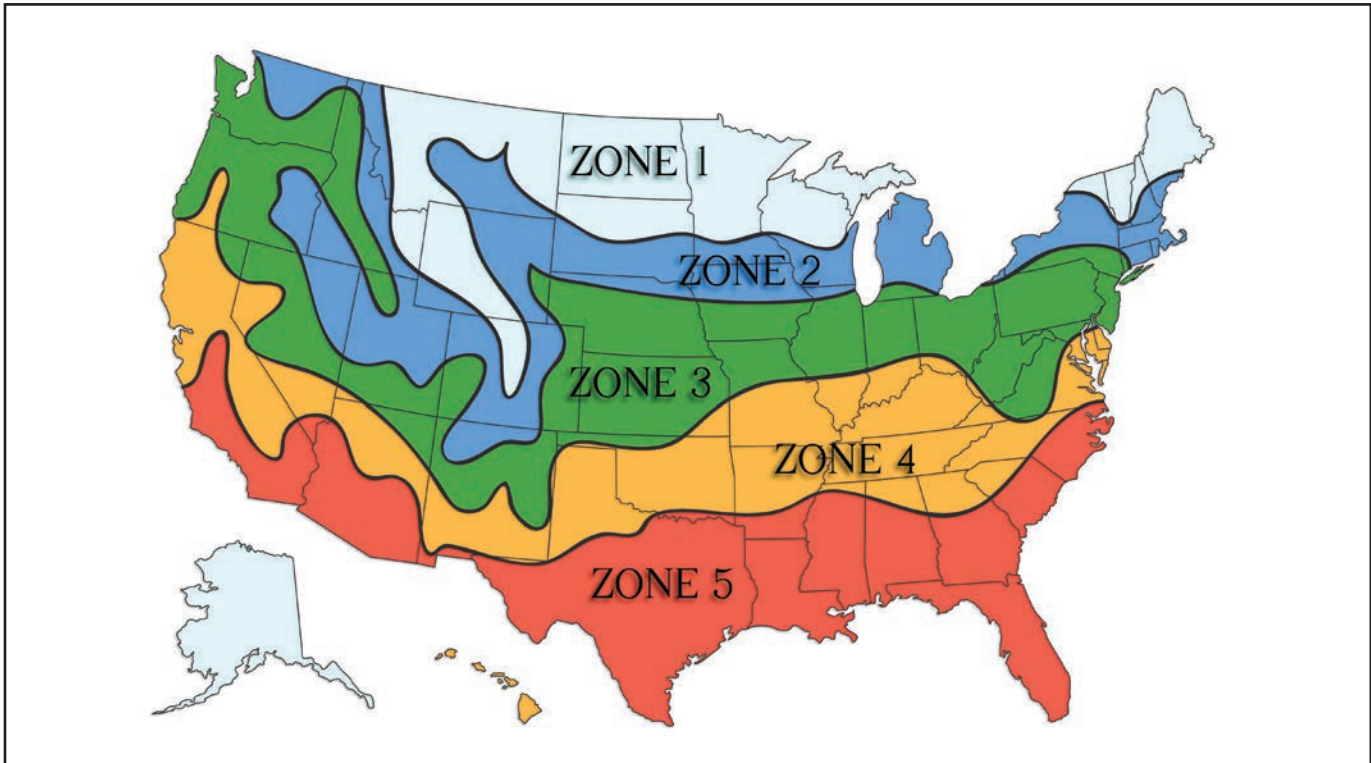

INSULATION			
R-VALUE	Recommended	FHA Standard	Minimum: Not Recommended
Ceiling	*R-24	*R-19	*R-11
Walls	R-13	11	R-7
Floor	R-24	11	----
ZONE	APPROXIMATE WATTAGE NEED PER SQUARE FOOT		
1	8.6	10.0	14.6
2	7.7	9.0	13.1
3	7.1	8.2	12.0
4	6.4	7.4	10.8
5	6.0	7.0	10.2

\*R values are industry standards for insulation effectiveness. Ask company representative for assistance if you do not know "R" for your present structure insulation.

**Baseboard or wall mount style? Recessed or surface type? It's easy to select the heater that's right for you.**

1. Measure the size of the room(s) or area you intend to heat for square footage. You will need the length times the width to get this calculation.
2. Find your location on the map above. This determines your basic heating zone.
3. The chart shown below the map lists insulation values based on the effectiveness of the insulation presently in your home. Find your heating zone on the chart and the approximate wattage per square foot you will need.
4. Multiply the total number of square feet you intend to heat by the approximate wattage per square foot you just obtained. This will determine your total heating requirement in watts for the room.

**How Much Heat is Right For You?**

Figures are based on 15% total window and door openings in outside walls, and 3/4 total home air changes per hour. Typical frame-type construction with unheated basement or unventilated crawl space. If you do not have storm doors and windows, add 30% to the watts per square foot (multiply by 1.3).

That's all there is to it! Now choose the heater with a wattage equal to what you need. Your final selection will, of course, depend on available wall space, window placement, ect.

**Sample Calculation:**

- Example = 10' x 12' room in Zone 3 with FHA standard insulation
1. Determine room square footage: 10' x 12' = 120 sq. ft.
  2. Zone 3 with FHA standard insulation requires 8.2 watts per sq. ft.
  3. Multiply square footage of room to be heated by the approximate wattage per square foot required.

120 sq. ft x 8.2 watts = 984 watts required.  
 From this calculation it can be reasoned that a 1000 watt heater would be required.



# HLA Series Hazardous Location Fan Forced Unit Heater

FAN-FORCED SUSPENDED UNIT HEATERS 3-25 KW FOR T-3B CLASS I, GROUP C & D, DIVISION 1 & 2 AND CLASS II, GROUPS E, F & G, DIVISIONS 1 & 2.

4



Shown with optional pilot light and disconnect switch



Manufactured in U.S.A.

- Designed for rugged industrial applications in hazardous locations where the possibility of explosion or fire exists due to the presence of certain flammable gases, vapors, powdered metals or dust.
- Permanently sealed, liquid to air, finned tube heat exchanger core.
- Ethylene Glycol to water mixture used as a heat transfer fluid in the heater core, providing -45° C. (-49° F) freeze damage protection.
- High-performance electric motor driven fan blows air across finned tubes to effect uniform heat transfer and area heat distribution.
- Manual Reset capillary type limit provides high temperature regulation and is rated for 6,000 cycles of service.
- Stainless steel and aluminum pressure relief valve for overpressure.
- A back-up contactor is included for additional protection.
- 14 gauge steel cabinet powder coated epoxy paint finish contains heater core, motor, and fan assembly.
- Narrow gap safety fan guard shields all moving parts.
- Adjustable louvers allow directional control of air.
- Copper conductor wires enclosed in rigid metal conduits carry all electrical power.
- Box lugs furnished for field connections within approved enclosure.

## Product Specifications

### Heat Exchanger and Elements:

Heavy walled, painted carbon steel with aluminum fins liquid heat exchanger, liquid filled with three-immersion type copper sheathed elements. The elements shall have the highest quality nickel-chromium resistance wire encased in a magnesium oxide dielectric and be hermetically sealed into the heat exchanger core. The heat transfer fluid is Ethylene-glycol solution for operation to -49 degrees F (-45 degrees C). Stainless steel and aluminum pressure relief valve for overpressure.

### Thermal Cutout High Limit Protection and Optional Pilot Light:

The capillary type manual reset thermal cutout shall be rated for 6000 cycles of service and mounted in the liquid filled heat exchanger. An optional pilot light to indicate manual reset tripped, if safe operating temperatures are exceeded, is located on control enclosure.

### Motor:

The motor shall be a permanent split capacitor type, permanently lubricated, ball bearing type. The motor shall be rated for hazardous location and operate at rated voltage of heater, 60 Hz, 1725 RPM.

### Control Enclosure:

All controls shall be factory installed and wired in a hazardous location enclosure. Contactors and back-up contactors are heavy duty type and break all ungrounded conductors and be rated for 100,000 cycles at full load. Standard 24-Volt control circuit shall be supplied by internal class II transformer. An optional factory wired integral thermostat or standard terminal block for field wiring to optional remote wall thermostat are wired in control panel. No fan delay relay.

### Disconnect Switch:

Factory mounted and wired hazardous location disconnect switch is available as optional accessory.

### Cabinet With Adjustable Louvers:

The Cabinet shall be 14 gauge, cold rolled steel with powder coated epoxy finish. Plated fan guards with less than 1/4 inch spacing to cover motor and fan shall conform to OSHA Requirements.

### Note:

Before selecting a hazardous location electric heater refer to Article 500 or other applicable standard referenced in the National Electric Code.



Liquid-to-air heat exchanger



Optional built-in thermostat



Hazardous Location Rated Motor

# HLA Series Hazardous Location Fan Forced Unit Heater

## Rating Definitions

**CLASS I:** Equipment does not have surface operating temperature in excess of the ignition temperature of the specific gas or vapor.

Application Examples:

- Offshore and land based drilling rigs, petroleum exploration and testing facilities.
- Petroleum refineries, gasoline storage and dispensing areas.
- Industrial firms that use flammable liquids in dip tanks for parts cleaning or other operations.
- Petrochemical companies that manufacture chemicals from gas or oil.
- Dry cleaning facilities where vapors from cleaning fluids may be present.
- Aircraft hangers and fuel servicing areas.
- Utility gas plants and operations involving storage and handling of liquefied petroleum or natural gas.

**GROUP C:** Atmospheres such as but not limited to acetaldehyde, allyl alcohol, hydrogen sulfide, ethylene, carbon monoxide, or other gases or vapors of equivalent hazard.

**GROUP D:** Atmospheres such as but not limited to acetone, alcohol, gasoline, lacquer solvent vapors, natural gas, propane or other gases or vapors of equivalent hazard.

**CLASS II:** Equipment does not have surface temperature greater than the ignition temperature of the specified dust.

Application Examples:

- Coal preparation plants and other carbon handling or processing areas.
- Grain elevators, flour and feed mills.
- Plants which manufacture, use or store Magnesium or Aluminum powders.
- Plants that have chemical or metallurgical processes.
- Producers of starch products or candy.
- Spice grinding plants, sugar plants and cocoa plants.

**GROUP E:** Atmosphere containing combustible metal dust regardless of resistivity, or other combustible dust of similar hazard characteristics having resistivity of less than  $10^5$  OHM - Centimeter.

**GROUP F:** Atmosphere containing carbon black, charcoal, coal or coke dust.

**GROUP G:** Atmospheres containing combustible dust having resistivity of  $10^5$  OHM-Centimeter or greater.

**DIVISION I:** A location in which ignitable concentrations of flammable material exist under normal operating conditions.

**DIVISION II:** Locations in which flammable materials will normally be confined within closed containers and escape only in the case of accidental rupture, breakdown or during maintenance operations. Any equipment approved for Division I is automatically also approved for Division II.

## Standard Hazardous Location Models

UPC#	MODEL	KW	BTU's	VOLTS	PH	AMPS	Control Voltage	Temp Rise °F	Air Throw	CFM	Recom'd Mounting Ht.	WT.
686334												
734356	HLA 12-208160-3.0-24	3	10250	208	1	16.3	24	16.5			8'	167 lb.
734004	HLA 12-208360-3.0-24			208	3	9.8						
734011	HLA 12-240160-3.0-24			240	1	14.8						
734028	HLA 12-240360-3.0-24			240	3	8.6						
734035	HLA 12-480360-3.0-24			480	3	4.3						
734363	HLA 12-208160-5.0-24	5	17100	208	1	26		27.6	24'	580	8'	167 lb.
734059	HLA 12-208360-5.0-24			208	3	15.4						
734066	HLA 12-240160-5.0-24			240	1	23.1						
734073	HLA 12-240360-5.0-24			240	3	13.4						
734080	HLA 12-480360-5.0-24			480	3	6.7						
734370	HLA 12-208160-7.5-24	7.5	25600	208	1	38		41.4			8'	167 lb.
734103	HLA 12-208360-7.5-24			208	3	22.3						
734110	HLA 12-240160-7.5-24			240	1	33.6						
734127	HLA 12-240360-7.5-24			240	3	19.4						
734134	HLA 12-480360-7.5-24			480	3	9.7						
734158	HLA 16-208360-10.0-24	10	34150	208	3	29.3	21.7	40'	1500	10'	193 lb.	
734165	HLA 16-240160-10.0-24			240	1	44						
734172	HLA 16-240360-10.0-24			240	3	25.5						
734189	HLA 16-480360-10.0-24			480	3	12.7						
734202	HLA 20-208360-15.0-24	15	51200	208	3	43.5	19.2	43'	2450	13'	193 lb.	
734219	HLA 20-240360-15.0-24			240	3	38.1						
734226	HLA 20-480360-15.0-24			480	3	19						
734233	HLA 20-600360-15.0-24			600	3	15.2						
734240	HLA 20-480360-20.0-24	20	68300	480	3	25.1	26.2			13'	225 lb.	
734257	HLA 20-600360-20.0-24			600	3	20						
734264	HLA 20-480360-25.0-24			480	3	31.1						
734271	HLA 20-600360-25.0-24	25	85400	600	3	24.9	32.8					



# HLA Series Hazardous Location Fan Forced Unit Heater

## Mounting Bracket Kits

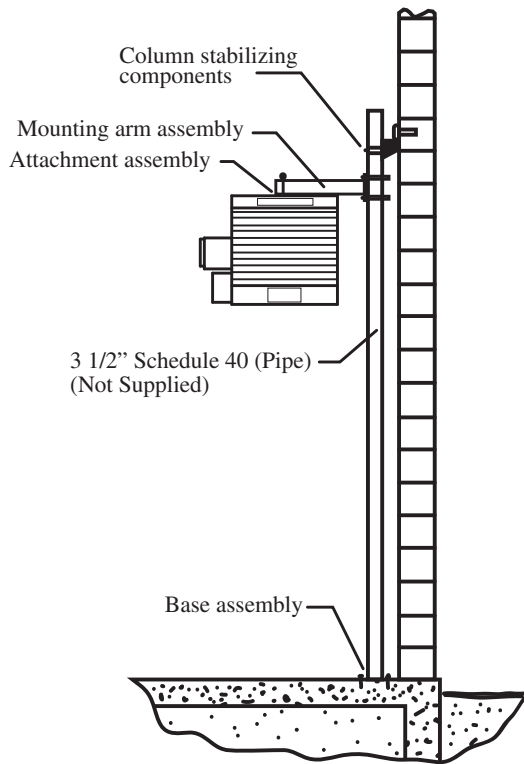

### HLPM Pipe Mounting Kit

Particularly useful in buildings with insufficient strength to use other types of mounts. Requires 3 1/2" pipe (4" O.D. - not supplied).

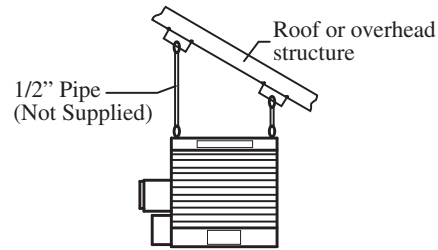

### HLHM Hanging Mounting Kit

Simple and economical if adequate overhead structure exists. Requires 1/2" pipe, cut and threaded (not supplied).

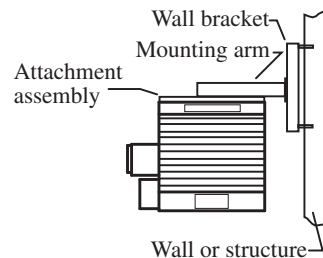

### HLWM Wall Mounting Kit

Ideal for use in buildings that have substantial walls. Arm only can also be bolted directly to structural steel.

UPC# 686334	NUMBER	USE WITH HEATERS	WT.
734288	HLPM37	3.0 KW - 7.5 KW	37 lbs.
734295	HLPM1015	10.0 KW	38 lbs.
734301	HLPM1525	15.0 KW - 25.0 KW	40 lbs.
734318	HLHM	ALL	5 lbs.
734325	HLWM37	3.0 KW - 7.5 KW	27 lbs.
734332	HLWM10	10.0 KW	28 lbs.
734349	HLWM1525	15.0 KW - 25.0 KW	29 lbs.

## EPET Series and HLT Series Hazardous Location Thermostats For Single Phase



HLT Series



Motor Rating (full load): 3/4 HP @ 125V, 1 1/2 HP @250V  
 Pilot Duty Rating 125VA @ 24VAC  
 NEMA Class Seven Div. 1 Approved  
 Class I Group C & D, Class II Group E, F, & G  
 Not rated for Group B

UPC# 686334	MODEL	DESCRIPTION	LOAD RATINGS	RANGE
538077	EPETD8D	DPDT - Bi-Metal	22A @120-277VAC	50-90°F
538107	EPETD8S	SPDT - Bi-Metal	22A @120-277VAC	50-90°F
528078	EPETP8D	DPDT - Bi-Metal	22A @120-480VAC	50-90°F
528061	EPETP8S	SPDT - Bi-Metal	22A @120-480VAC	50-90°F
523158	HLT-1	SPDT - Capillary	22A @120-277VAC	40-110°F
523165	HLT-2	DPDT - Capillary	22A @120-277VAC	40-110°F
Master ctn: 4 pcs, 24 lbs (varies slightly by model), 16" x 14.5" x 6"				
EPET Series incorporate plastic knob & Bi-Metal Sensor housing.				
HLT Series incorporates screwdriver temperature adjustment slot and all metal housing. External bulb and capillary sensor.				

### Features

- SPDT & DPDT Models
- Heat or cool compatible
- Celsius and Fahrenheit temperature scale
- Bi-Metal or capillary sensor
- Snap action switch
- Casting tapped top and bottom for 3/4" conduit
- 1/2" thick cast aluminum housing
- Dimension 5.75" x 6.375" x 5.57"

# HLA Series Hazardous Location Fan Forced Unit Heater

## Factory Installed Accessories & Physical Dimensions

SUFFIX	DESCRIPTION
T	In-Built single pole thermostat 50° - 90° F
120	Control transformer w/ primary fusing (Delete 24 suffix - add 120)
208	208/240V Control available on 208/240V units (Delete 24 suffix and add 208 OR 240)
240	
D	Disconnect Switch
P	Pilot Light

MODEL	A	B	C		D	E	F	G
			3 ph.	1 ph.				
HLA 12	17 3/4	22 3/8	19 3/4	20 5/8	16 1/4	10 1/2	14	3
HLA 16	20 3/4	26 3/8	20 3/4	21 5/8	20 1/4	11 1/2	18	4
HLA 20	24 3/4	30 3/8	22 1/2	N/A	24 1/4	12 1/2	22	4 1/2

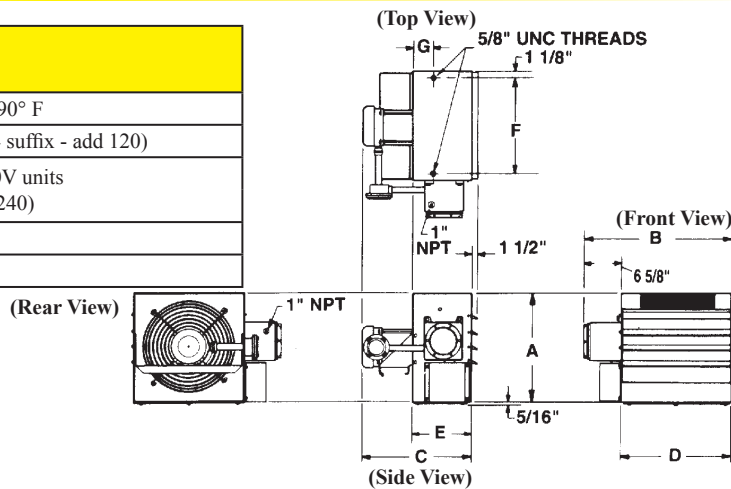

# PHLA Series Portable Hazardous Location Fan Forced Unit Heater



- 3.0 through 25 KW rating
- 208, 240, 480, 600 Volt available in selected capacities
- Cart has anti-static wheels to reduce the risk of static discharge
- Wheeled cart allows for easy maneuverability
- Cart has integrated fork-lift channels to provide ease of lifting on to ramps or trucks
- Excellent for providing seasonal heating in hazardous environments
- All units have disconnect switch, pilot light, and thermostat - standard
- 24 Volt control, transformer, and contactor in NEMA 7 enclosure
- Durable epoxy coating on heater housing
- Hazardous location unit mounted male / female plug
- Adjustable louvers; manual reset

## Standard Portable Hazardous Location Models

UPC #	MODEL	KW	BTU	VOLTS	PH	AMPS	TEMP RISE F	AIR THROW	CFM	WT
686334										
739344	PHLA12-208160-3.0-24-TDP	3	10,250	208	1	16.3	16.5	24'	580	260
739337	PHLA12-208360-3.0-24-TDP			208	3	9.8				
739320	PHLA12-240160-3.0-24-TDP			240	1	14.8				
739313	PHLA12-240360-3.0-24-TDP			240	3	8.6				
739306	PHLA12-480360-3.0-24-TDP			480	3	4.3				
739436	PHLA12-600360-3.0-24-TDP			600	3	3.5				
739290	PHLA12-208160-5.0-24-TDP	5	17,100	208	1	26	27.6	24'	580	260
739283	PHLA12-208360-5.0-24-TDP			208	3	15.4				
739276	PHLA12-240160-5.0-24-TDP			240	1	23.1				
739269	PHLA12-240360-5.0-24-TDP			240	3	13.4				
739252	PHLA12-480360-5.0-24-TDP			480	3	6.7				
739429	PHLA12-600360-5.0-24-TDP			600	3	5.4				
739245	PHLA12-208160-7.5-24-TDP	7.5	25,600	208	1	38	41.4	24'	580	260
739238	PHLA12-208360-7.5-24-TDP			208	3	22.3				
739221	PHLA12-240160-7.5-24-TDP			240	1	33.6				
739214	PHLA12-240360-7.5-24-TDP			240	3	19.4				
739207	PHLA12-480360-7.5-24-TDP			480	3	9.7				
739412	PHLA12-600360-7.5-24-TDP			600	3	7.8				
739191	PHLA16-208360-10.0-24-TDP	10	34,150	208	3	29.3	21.7	40'	1500	305
739184	PHLA16-240160-10.0-24-TDP			240	1	44				
739177	PHLA16-240360-10.0-24-TDP			240	3	25.5				
739160	PHLA16-480360-10.0-24-TDP			480	3	12.7				
739405	PHLA16-600360-10.0-24-TDP			600	3	10.2				
739153	PHLA20-208360-15.0-24-TDP			208	3	43.5				
739146	PHLA20-240360-15.0-24-TDP	15	51,200	240	3	38.1	19.2	43'	2450	350
739139	PHLA20-480360-15.0-24-TDP			480	3	19				
739399	PHLA20-600360-15.0-24-TDP			600	3	15.2				
739122	PHLA20-480360-20.0-24-TDP	20	68,300	480	3	25.1	26.2	43'	2450	350
739382	PHLA20-600360-20.0-24-TDP			600	3	20				
739115	PHLA20-480360-25.0-24-TDP			480	3	31.1				
739375	PHLA20-600360-25.0-24-TDP	25	85,400	600	3	24.9	32.8	43'	2450	350



# FEP Series Single Phase Hazardous Location Wall Convectors

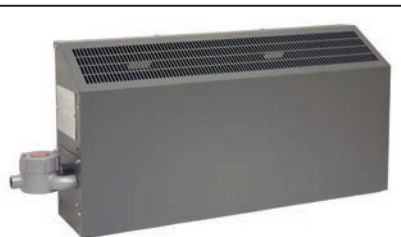

Standard Unit



Unit with optional control section containing disconnect, pilot light, and thermostat (Suffix C1-TDP)



Unit with in-built EPET line voltage thermostat (Suffix T1 or T2)

Manufactured in U.S.A.

- Cabinet size 18" high, 9" wide.
- Bottom In - Front Out air flow.
- Wall mounting bracket supplied.
- Units cannot be operated in room ambients exceeding 104°F (40°C).
- Heavy duty 16 gauge steel with gray epoxy textured powder coated finish.
- 9" minimum clearance from bottom of heater to floor required.
- Stainless steel cartridge element inserted into Aluminum finned Copper sheath.
- Standard unit (without EPET thermostat or control section) is NEMA 4 rated.



T-2A SERIES SINGLE PHASE Class 1, Group B, C & D Division 1 & 2 280° C / 536° F							
UPC 686334	MODEL	WATTS	BTU's	VOLTS	AMPS	CABINET LENGTH	WT. (LBS.)
445146	FEP-1812-1RA	1800	6143	120	15.0	34"	50
445153	FEP-1820-1RA			208	8.7		
445160	FEP-1824-1RA			240	7.5		
445177	FEP-1827-1RA			277	6.5		
445184	FEP-1848-1RA			480	3.8		
445191	FEP-3620-1RA	3600	12286	208	17.3	34"	54
445207	FEP-3624-1RA			240	15.0		
445214	FEP-3627-1RA			277	13.0		
445221	FEP-3648-1RA			480	7.5		
445238	FEP-3657-1RA			600	6.0		
445245	FEP-3820-1RA	3800	12969	208	18.3	58"	80
445252	FEP-3824-1RA			240	15.8		
445269	FEP-38271-RA			277	13.7		
445276	FEP-3848-1RA			480	7.9		
445283*	FEP-7620-1RA			7600	25938		
445290*	FEP-7624-1RA	240	31.7				
445306*	FEP-7627-1RA	277	27.4				
445313	FEP-7648-1RA	480	15.8				
445320	FEP-7657-1RA	600	12.7				

\*Items may not be used with 22 Amp line voltage thermostat



T-3A SERIES SINGLE PHASE Class 1, Group B, C & D Division 1 & 2 180° C / 356° F							
445337	FEP-0812-1RA	800	2730	120	6.7	34"	50
445344	FEP-0820-1RA			208	3.8		
445351	FEP-0824-1RA			240	3.3		
445368	FEP-0827-1RA			277	2.9		
445375	FEP-0848-1RA			480	1.7		
445382	FEP-1612-1RA	1600	5460	120	13.3	34"	54
445399	FEP-1620-1RA			208	7.7		
445405	FEP-1624-1RA			240	6.7		
445412	FEP-1627-1RA			277	5.8		
445429	FEP-1648-1RA			480	3.3		
445436	FEP-1657-1RA	1700	5802	600	2.7	58"	80
445443	FEP-1712-1RA			120	14.2		
445450	FEP-1720-1RA			208	8.2		
445467	FEP-1724-1RA			240	7.1		
445474	FEP-1727-1RA			277	6.1		
445481	FEP-1748-1RA	3400	11604	480	3.5	58"	85
445498	FEP-3420-1RA			208	16.3		
445504	FEP-3424-1RA			240	14.2		
445511	FEP-3427-1RA			277	12.3		
445528	FEP-3448-1RA			480	7.1		
445535	FEP-3457-1RA	600	5.7				

## Factory Installed Control Options

SUFFIX*	DESCRIPTION	SUFFIX**	DESCRIPTION
T1	EPETD8S single pole thermostat factory mounted to 120V - 480V units	C1-TD	Control section with transformer, 24V contactor, SP thermostat (40°F - 90°F) and disconnect switch (all units)
T2	EPETD8D double pole thermostat factory mounted to 120V - 480V units	C1-TDP	Control section with transformer, 24V contactor, SP thermostat (40°F - 90°F), disconnect switch & pilot light (all units)

\*Remove - RA suffix and add new suffix. \*\*Remove - RA suffix and add new suffix (Not NEMA washdown rated or rated for Group B atmospheres)  
Suffix "T" is 22 Amps maximum.

# FEP Series Three Phase Hazardous Location Wall Convectors

- Cabinet size 18" high, 9" wide.
- Bottom In - Top Out air flow.
- Wall mounting bracket supplied.
- Units can not be operated in room ambients exceeding 104°F (40°C).
- Heavy duty 16 gauge steel with gray epoxy textured powder coated finish.
- 9" minimum clearance from bottom of heater to floor required.
- Stainless steel cartridge element inserted into Aluminum finned Copper sheath.
- Standard unit (without EPET thermostat or control section) is NEMA 4 rated.
- ABS (American Bureau of Shipping) type approved.

T-2A SERIES THREE PHASE Class 1, Group B, C, & D Divisions 1 & 2 280° C / 536° F							
UPC 686334	MODEL	WATTS	BTU's	VOLTS	AMPS	CABINET LENGTH	WT. (LBS.)
483056	FEP-1820-3RA	1800	6143	208	5.0	34"	50
483063	FEP-1824-3RA			240	4.3		
486224	FEP-1848-3RA			480	2.2		
483070	FEP-3620-3RA	3600	12286	208	10.0	34"	54
483087	FEP-3624-3RA			240	8.7		
486231	FEP-3648-3RA			480	4.3		
483094	FEP-3820-3RA	3800	12969	208	10.5	58"	80
483100	FEP-3824-3RA			240	9.1		
486248	FEP-3848-3RA			480	4.6		
483117	FEP-7620-3RA	7600	25938	208	21.1	58"	85
483124	FEP-7624-3RA			240	18.3		
486255	FEP-7648-3RA			480	9.2		

T-3A SERIES THREE PHASE Class 1, Group B, C & D Division 1 & 2 180° C / 356° F							
UPC 686334	MODEL	WATTS	BTU's	VOLTS	AMPS	CABINET LENGTH	WT. (LBS.)
483131	FEP-0820-3RA	800	2730	208	2.2	34"	50
483148	FEP-0824-3RA			240	1.9		
486262	FEP-0848-3RA			480	0.9		
483155	FEP-1620-3RA	1600	5460	208	4.4	34"	54
483162	FEP-1624-3RA			240	3.8		
486279	FEP-1648-3RA			480	1.9		
483179	FEP-1720-3RA	1700	5802	208	4.7	58"	80
483186	FEP-1724-3RA			240	4.1		
486286	FEP-1748-3RA			480	2.0		
483193	FEP-3420-3RA	3400	11604	208	9.4	58"	85
483209	FEP-3424-3RA			240	8.2		
486293	FEP-3448-3RA			480	4.1		

\*T1 and T2 option not available on 3 phase models

## Factory Installed Control Options

SUFFIX**	DESCRIPTION
C1-TD	Control section with transformer, 24V contactor, SP thermostat (40°F - 90°F) and disconnect switch (all units)
C1-TDP	Control section with transformer, 24V contactor, SP thermostat (40°F - 90°F), disconnect switch & pilot light (all units)

\*\*Remove - RA suffix and add new suffix (Not NEMA washdown rated or rated for Group B atmospheres)

Note: C1-TD and C1-TDP are only options available for 3 phase units.

## Remote Mounted Hazardous Location Thermostats For Single Phase Models Only

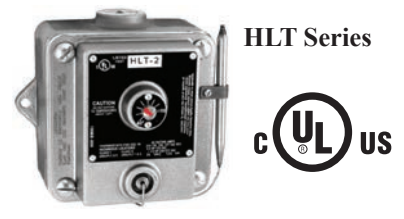

HLT Series  
UL US

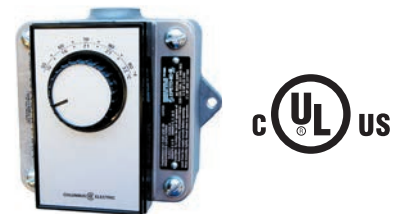

EPET Series  
UL US

UPC# 686334	MODEL	DESCRIPTION	LOAD RATINGS	RANGE
538077	EPETD8D	DPDT - Bi-Metal	22A @120-277VAC	50-90°F
538107	EPETD8S	SPDT - Bi-Metal	22A @120-277VAC	50-90°F
528078	EPETP8D	DPDT - Bi-Metal	22A @120-480VAC	50-90°F
528061	EPETP8S	SPDT - Bi-Metal	22A @120-480VAC	50-90°F
523158	HLT-1	SPDT - Capillary	22A @120-277VAC	40-110°F
523165	HLT-2	DPDT - Capillary	22A @120-277VAC	40-110°F
Master ctn: 4 pcs, 24 lbs (varies slightly by model), 16" x 14.5" x 6"				
EPET Series incorporates plastic knob & Bi-Metal Sensor housing.				
HLT Series incorporates screwdriver temperature adjustment slot and all metal housing. External bulb and capillary sensor.				

## EPET Series Parameters

Dimensions: Height 5 5/8", Width 6 3/8", Depth 4 1/2"  
 Finish: Silver-Gray  
 Type: Single or Double Pole

Motor Rating: (full load) 1 1/2 HP @ 250V  
 Rating: 22A @ 125-277VAC; 125VA @ 24VAC  
 Rated: Class I Group C & D, Class II Group E, F, G  
 Thermostat is not rated for use in Group B environments.

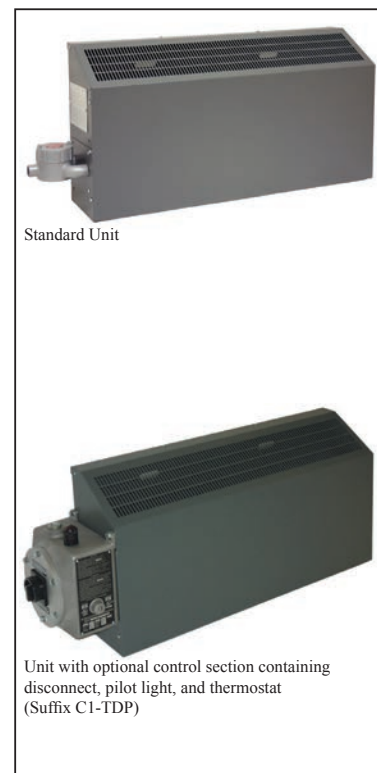

Standard Unit

Unit with optional control section containing disconnect, pilot light, and thermostat (Suffix C1-TDP)

Note: Controls mounted on the left side only.





# 5500 Series Washdown Fan Forced Unit Heater

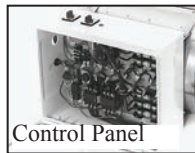
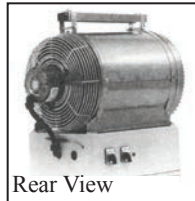

Manufactured in U.S.A.

- Heavy-duty 304 16 gauge stainless steel shroud.
- 316 stainless construction available.
- Nema 4x non-metallic control panel.
- 24-Volt transformer and control panel.
- 3-position switch (off-heat-fan).
- Capillary thermostat with stainless steel sensor.
- Automatic reset thermal cutout.
- Totally enclosed U.L. listed motor.
- Pilot light (power on indicator).



The Washdown Series unit heaters are electric unit heaters constructed for use in areas that require washing or hosing of equipment due to dirty or dusty industrial environments in non-hazardous locations. The totally enclosed water-tight construction made with corrosion-resistant material make this series ideal for industrial heating applications. The Washdown Series is constructed with all built-in controls and safety temperature controls wired in a non-metallic Nema 4x control panel with single-point power connections.

- Stainless steel finned tubular element. Constructed of 304 or 316 stainless rod and fins.
- Control panel on bottom of unit for ease of installation and service.
- Disconnect switch with enclosure door interlock.
- Front grill rotates to direct airflow.
- Single-point power connection.
- Fan Blade Epoxy coated Aluminum.
- Epoxy painted cold roll steel model available, consult factory
- Meets all U.L., NEC, and OSHA requirements (when installed as directed).
- Corrosion-resistant in high humidity and water-saturated areas (for areas where corrosion resistance is needed in non-explosive areas, contact factory for heater applications and optional materials).
- ABS (American Bureau of Shipping) type approved.
- Thermostat temp range: 40°-100°F



## Mounting Bracket Kits & Product Dimensions

SIZE KW	UPC# 686334	STAINLESS STEEL COMBINATION BRACKET	UPC# 686334	WALL MTG. BRACKET *	UPC# 686334	HANGING BRACKET *	UPC# 686334	PIPE MTG. BRACKET *
3.3-15	713672	A5520/UHB	713726	W5520/WMK	713702	H5520/HMK	713689	P5520/PMK
20-48		----	713733	W5550/WMK	713719	H5550/HMK	713696	P5550/PMK

\* Material: Heavy Duty Epoxy Powder Coat Finish.

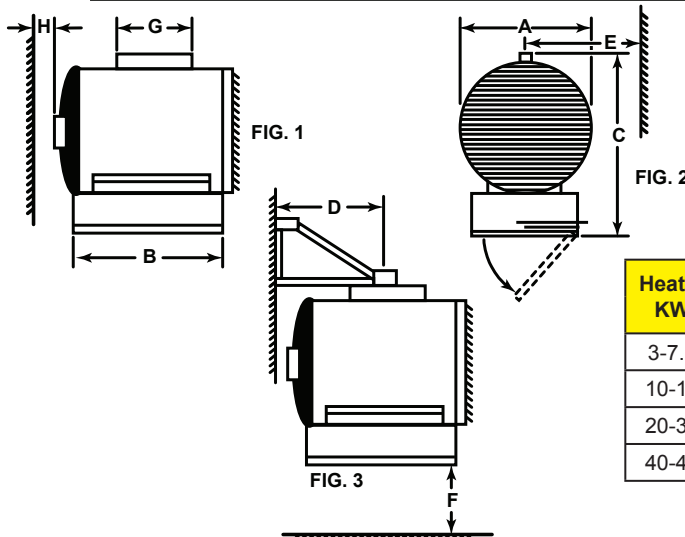
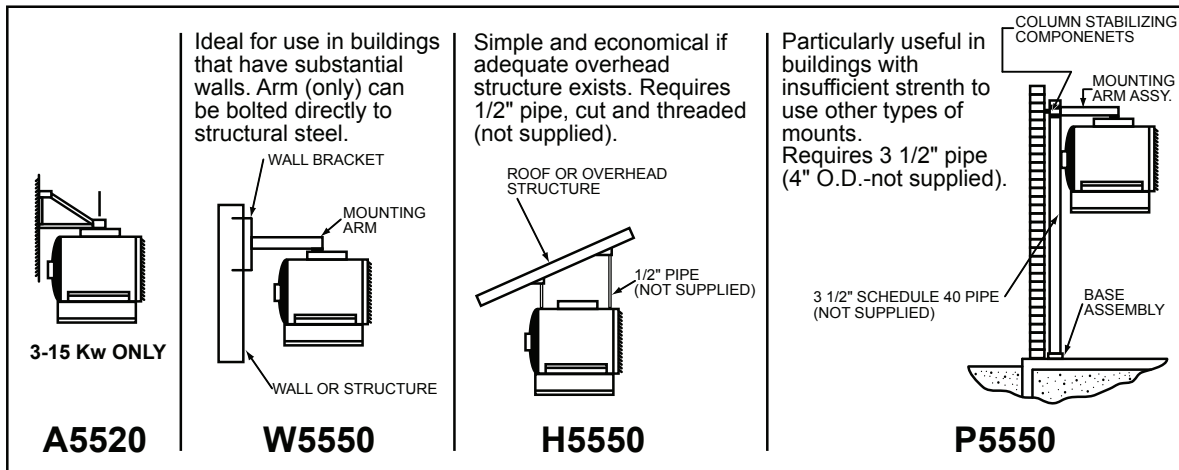

Heater KW	Heater Dimension in Inches unless otherwise stated.							
	A	B	C	D	E	F	G	H
3-7.5	12.00	18.00	19.75	15.25	16.25	6 ft.	8.00	6.00
10-15	14.00	19.00	21.75	15.25	18.00		8.00	6.00
20-30	16.00	27.00	28.75	19.50	17.50		15.50	4.50
40-48	18.00	31.00	30.75	19.50	19.50		21.75	2.75

# 5500 Series Washdown Fan Forced Unit Heater

## Product Specifications & Standard Washdown Models

**Enclosure and Motor:** Element housing shall be 16 gauge 304 or 316 stainless steel shroud. The outlet grill and louver assembly shall be 304/316 stainless steel and rotate for direction of discharge air. The heater shall have a 304/316 stainless steel inlet grill and fan guard. The motor shall be totally enclosed, permanently lubricated and designed to resist moisture and corrosion. The fan blade shall be aluminum with a powder coated epoxy finish.

**Element:** The heating element shall be 304 or 316 stainless steel tube with 304/316 stainless steel fin material helically attached to the tube for even heat transfer. The element designed with the highest quality nickel-chromium resistance wire embedded in compacted efficient dielectric to ensure proper heat transfer.

**Control Panel:** The control enclosure shall be non-metallic Nema 4X control panel water-tight and dust-tight. The enclosure and elements are attached to the control panel with stainless steel fasteners. Standard control components are factory mounted and wired with access through control panel door on bottom of heater assembly. A standard door interlock disconnect switch shall be factory mounted and wired for safety.

**Controls:** All controls shall be factory mounted and wired in Nema 4X panel. Terminal block, 24 Volt transformer, high temperature limits, contactor and fusing if required by NEC are mounted and wired in control panel. A three-position switch (Off-Heat-Fan) shall be mounted on side of control panel for access from outside of panel. A pilot light to indicate power is on for safety shall be located on side of control panel. A wall mounted Nema 4X thermostat is an optional accessory.

**Mounting Bracket:** A formed 304/316 stainless steel bracket shall be used on 3.3 thru 15 KW units. A cast iron epoxy painted bracket shall be used on 20 thru 48 KW units. Above brackets shall be combination wall/ceiling type. Optional mounting brackets are available.

UPC# 686334	MODEL	KW	BTU's	VOLTS	PH	AMPS	CONTROL VOLTAGE	TEMP RISE °F	AIR THROW	CFM	WT (LBS)
713047	F1F5503T	3	11200	208	1	16	24	26			
713054	F3F5503T			208	3	9					
713061	H1H5503T			240	1	14					
713078	H3H5503T			240	3	8					
713085	G1G5503T			277	1	12					
713092	P3P5503T			480	3	4					
713115	F1F5505T	5	17100	208	1	24		40	20'	400	58
713122	F3F5505T			208	3	14					
713139	H1H5505T			240	1	21					
713146	H3H5505T			240	3	12					
713153	G1G5505T			277	1	18					
713160	P3P5505T			480	3	6					
713184	F1F5507T	7.5	25600	208	1	36		60			
713191	F3F5507T			208	3	21					
713207	H1H5507T			240	1	31					
713214	H3H5507T			240	3	13					
713221	G1G5507T			277	1	27					
713238	P3P5507T			480	3	9					
713252	F1F5510T	10	34130	208	1	48		45			
713269	F3F5510T			208	3	28					
713276	H1H5510T			240	1	41					
713283	H3H5510T			240	3	24					
713290	G1G5510T			277	1	36					
713306	P3P5510T			480	3	12					
713399	F1F5515T	15	51200	208	1	72	68				
713405	F3F5515T			208	3	42					
713412	H1H5515T			240	1	63					
713429	H3H5515T			240	3	36					
713443	P3P5515T			480	3	18					
713467	F3F5520T			208	3	56					
713474	H3H5520T	240	3	48	45						
713481	P3P5520T	480	3	24							
713504	F3F5525T	208	3	70							
713511	H3H5525T	25	85325	240	3	60	56	35'	1400	92	
713528	P3P5525T			480	3	30					
713542	F3F5530T			208	3	83					
713559	H3H5530T	30	102390	240	3	72	68				
713566	P3P5530T			480	3	36					
713603	P3P5540T	40	136520	480	3	48	70	42'	1800	126	
713641	P3P5548T	48	163824	480	3	58	84				

### Remote Rain-Tight Thermostat



UPC# 686334	MODEL	DESCRIPTION
523424	TW155A	1 POLE, 40-110 deg F, 22Amp
523431	TW255A	2 POLE, 40-110 deg F, 22Amp

Note: NEMA 4X Construction Stainless Steel Hardware  
 Note: Products listed in this section are custom built and subject to 100% cancellation/restock charges.

# UH Series Horizontal Fan Forced Unit Heater

3.3 KW THROUGH 48 KW HORIZONTAL DISCHARGE SUSPENDED FAN FORCED UNIT HEATERS  
AVAILABLE IN 1 OR 3 PHASE FOR ALL STANDARD VOLTAGES FROM 208V TO 480V.



Manufactured in U.S.A.



**NOTE:** Louver assembly is square and mounted with screws. Louver can be removed and repositioned for four (4) directional air flow - left - right - up - down with the heater in the horizontal position.

**FACTORY INSTALLED OPTIONS:**

- 24 Volt transformer on 3 KW to 15KW units to convert from line voltage to low voltage remote thermostat operation.
- Summer fan switch to operate the fan only.
- Fan delay switch to purge all residual heat from the unit after the heating element has cycled off.
- Powder coated epoxy finish for corrosive atmospheres.
- Disconnect switch.

MAXIMUM RECOMMENDED MOUNTING HEIGHT	
3 - 10 KW	9 FT.
12 - 15 KW	10 FT.
20 - 30 KW	13 FT.
40 - 48 KW	16 FT.

**CONSTRUCTION:**

Heavy gauge welded steel cabinet with powder coated finish and control compartment with a hinged and latched access door, simplifying wiring installation & maintenance.

**HEATING ELEMENT:**

Circular copper clad steel sheath element with continuously brazed steel fins formed to match the air delivery pattern of the fan blade.

**OVERHEAT PROTECTION:**

All units come equipped with automatic resetting type limit controls to de-energize the heater should an over-temperature situation occur.

**FAN and MOTOR:**

Totally enclosed, single phase, permanently lubricated, thermally protected motors with unit bearings on 3 KW - 10 KW models and sleeve bearings on 12.5 KW - 48 KW models - mounted with rubber insulators to minimize vibration and noise. Fan assembly enclosed by a heavy gauge, close spaced, chrome plated wire guard.

**LOUVER ASSEMBLY:**

Louvers are individually adjustable for directional control of air flow and the entire assembly can be repositioned in the field from down flow to up flow or left / right directional air flow.

**TEMPERATURE CONTROLS:**

20 KW through 48 KW units and all 480V have built in 24 Volt transformer for low voltage remote thermostat application. 25 KW through 48 KW models available in 2-stage on special order (consult factory).

**INSTALLATION:**

Unit Heaters can be mounted with the motor shaft from horizontal to downward at 45° off horizontal. Pre-drilled holes and installed threaded nuts provided to allow hanging by threaded rods - 1/4" for units up to 15 KW and 5/16" for 20 KW units and larger. Optional wall / ceiling mounting brackets are available for all units.

*Product Dimensions & Model Number Designation*

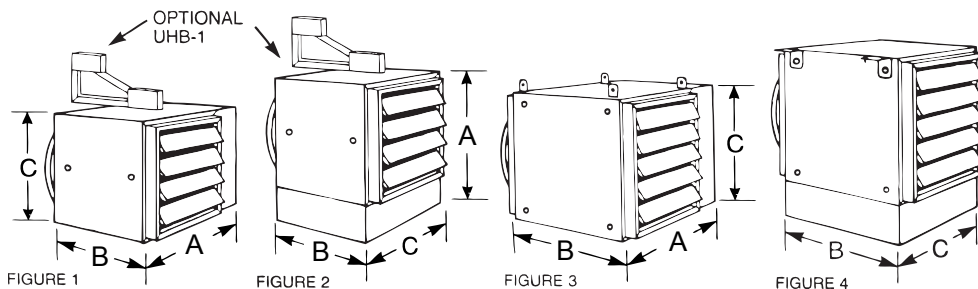

Dimensions	A	B	C
<b>Figure 1:</b> 3.3, 5, 7.5, 10 KW	20"	11"	13"
<b>Figure 2:</b> 12.5, 15 KW	22"	11"	15"
<b>Figure 3:</b> 20, 25, 30 KW	24"	17"	17"
<b>Figure 4:</b> 40, 48 KW	26"	23"	19"

3.3 KW THROUGH 15 KW UNIT HEATERS

20 KW THROUGH 48 KW UNIT HEATERS

Figures 3 & 4 shown with standard mounting tabs for units over 20 KW. Optional UHB-3 and UHB-4 wall brackets are available. 3.3 KW thru 15 KW units can be mounted using 1/4" threaded rod. 20 KW thru 48 KW units can be mounted using 5/16" threaded rod.

**HOW TO DESIGNATE A MODEL:**

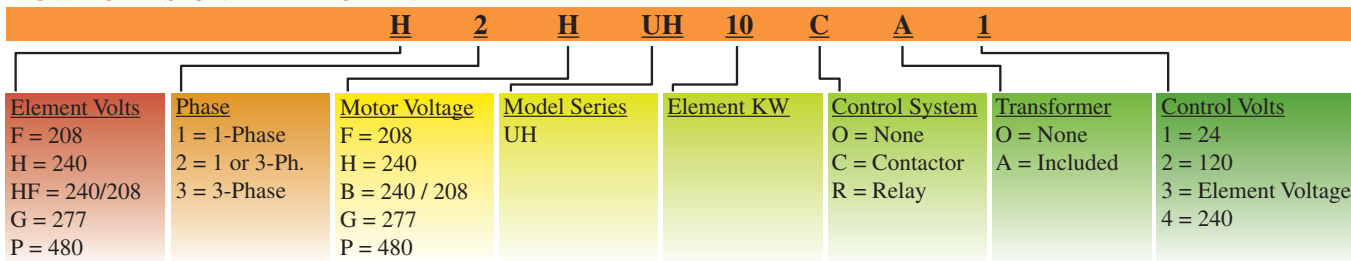

**Factory Installed Options** (use as a suffix on model designation):

S = Summer Fan Switch, F = Fan Delay, D = Disconnect, T = Built-in Thermostat, E = Epoxy Coated

**Field Installed Options:**

Disconnect Switch, Built-in Thermostat, & Wall / Ceiling Bracket



# UH Series Horizontal Fan Forced Unit Heater

## Standard Product Models

UPC# 686334	MODEL	KW	BTU'S	VOLTS	PH	AMPS	CONTROL VOLTS	TEMP RISE °F	AIR THROW	CFM	RECOM'D MOUNTING HT.	WT. (LBS.)							
644600	F1FUH03003	3.3	11,200	208	1	16	208	26	26'	400		36							
644662	H1HUH03003			240	1	14	240												
644723	G1GUH03003			277	1	12	277												
711487	H3HUH03C03			240	3	8	240												
711494	F3FUH03C03			208	3	9	208												
711401	P3PUH03CA1			480	3	4	24												
644617	F1FUH05003	5	17,100	208	1	24	208	40	26'	400		36							
644679	H1HUH05003			240	1	21	240												
644730	G1GUH05003			277	1	18	277												
644938	F2FUH05C03			208	1 or 3	24.1/14.0	208												
644945	H2HUH05C03			240	1 or 3	20.8/12.1	240												
644884	P3PUH05CA1			480	3	6	24												
644624	F1FUH07CA1	7.5	25,600	208	1	36	24	42	36'	575	9'	40							
688550	H1HUH07CA1			240	1	31	24					41							
644747	G1GUH07CA1			277	1	27	24					41							
644792	F3FUH07C03			208	3	21	208					44							
644952	H2HUH07C03			240	1 or 3	31.3/18.1	240												
644891	P3PUH07CA1			480	3	9	24												
644631	F1FUH10CA1	10	34,100	208	1	48	24	55	36'	575		42							
644693	HIHUH10CA1			240	1	42	24												
644754	G1GUH10CA1			277	1	36	24												
644969	F2FUH10C03			208	1 or 3	48.1/27.8	208												
644976	HF2HUH10C03	10/7.5	34,100	240	1 or 3	41.7/24.1	240	55				45							
			25,600	208	1 or 3	36.1/20.8	208	42				51							
711425	P3PUH10CA1	10	34,100	480	3	12	24	55	49	45'	800	45							
644648	F1FUH12C03	12.5	42,600	208	1	60	208												
644709	H1HUH12C03			240	1	52	240												
644815	F3FUH12C03			208	3	35	208												
644860	H3HUH12C03			240	3	30	240												
711432	P3PUH12CA1			480	3	15	24												
644655	F1FUH15C03			15	51,200	208	1	72	208	59	45'	800	10'	54					
644716	H1HUH15C03	240	1			63	240												
644822	F3FUH15C03	208	3			42	208												
644877	H3HUH15C03	240	3			36	240												
711449	P3PUH15CA1	480	3			18	24												
688307	F1FUH20CA1	20	68,300			208	1	96	24						47	56'	1350		55
688420	H1HUH20CA1			240	1	83	24												
688314	F3FUH20CA1			208	3	56	24												
688437	H3HUH20CA1			240	3	48	24												
688321	P3PUH20CA1			480	3	24	24												
688444	F1FUH25CA1			25	85,300	208	1	120	24	58	56'	1350	13'	55					
688338	H1HUH25CA1	240	1			104	24												
688451	F3FUH25CA1	208	3			70	24												
688345	H3HUH25CA1	240	3			60	24												
688468	P3PUH25CA1	480	3			30	24												
688475	H1HUH30CA1	30	102,390			240	1	125	24						70	56'	1350		60
688369	F3FUH30CA1			208	3	83	24												
688482	H3HUH30CA1			240	3	72	24												
688376	P3PUH30CA1			480	3	36	24												
688406	P3PUH40CA1			40	136,500	480	3	48	24	55	56'	2275	16'	75					
688789	P3PUH48CA1			48	163,800	480	3	58	24	67	56'	2275		78					

### Factory & Field Installed Accessories

FACTORY INSTALLED OPTIONS	
SUFFIX	DESCRIPTION
F	Heat purge fan delay switch for 208 / 240 / 277V units (includes contactor & transformer)
	Heat purge fan delay switch for 480V units (contactor & transformer standard in unit)
S	Summer fan switch
CA1	24V Transformer (3.3 KW - 15 KW units) & Contactor
CA2	120V Transformer (3.3 KW - 15 KW units) & Contactor
E	Epoxy Coating
T	SPST Thermostat
D	Disconnect Switch - 30 Amps
	Disconnect Switch - 40 Amps
	Disconnect Switch - 80 Amps
	Disconnect Switch - 100 Amps

FIELD INSTALLED ACCESSORIES		
UPC# 686334	MODEL	DESCRIPTION
646239	DCS303	30 Amp Disconnect Kit
646246	DCS403	40 Amp Disconnect Kit
646253	DCS803	80 Amp Disconnect Kit
646260	DCS1003	100 Amp Disconnect Kit
687997	TUH1	25 Amp SPST Thermostat Kit
699105	UHB-1	wall / ceiling bracket - 3.3 KW - 15 KW units
699112	UHB-3	wall / ceiling bracket - 20 KW - 30 KW units
699129	UHB-4	wall / ceiling bracket - 35 KW - 48 KW units

**NOTE:** Factory installed heat purge fan delay option (F) requires unit to have CA1 or CA2 factory installed

# 5100 Series Horizontal or Vertical Mounted Fan Forced Unit Heater

3.3 KW THROUGH 50 KW SUSPENDED FAN FORCED UNIT HEATERS AVAILABLE IN 1 OR 3 PHASE FOR ALL STANDARD VOLTAGES FROM 208V TO 480V THAT CAN BE MOUNTED TO PROVIDE HORIZONTAL OR VERTICAL DISCHARGE.



Horizontal Discharge



Vertical Discharge

Manufactured in U.S.A.

### FIELD INSTALLED OPTIONS:

- In-unit or wall mounted temperature control thermostats low or line voltage.
- Summer fan switch to operate the fan only.
- Power disconnect switch.
- Heat stratification thermostat.

### CONSTRUCTION:

Heavy 18 gauge welded steel cabinet with powder coated finish and control compartment housing a master terminal board with a hinged and latched access door, simplifying wiring, installation & maintenance.

### HEATING ELEMENT:

Copper clad steel sheath element with continuously brazed steel fins formed to allow side draw through air flow.

### OVERHEAT PROTECTION:

All units come equipped with automatic reset type limit controls to de-energize the heater should an over-temperature situation occur.

### FAN and MOTOR:

Totally enclosed, 1-speed, 1-phase, permanently lubricated, thermally protected motors with unit bearings on 3 KW - 20 KW models. Totally enclosed, 2-speed, 1-phase, permanently lubricated, thermally protected motors with sleeve bearings on 25 KW - 50 KW models. All motors mounted with rubber insulators to minimize vibration & noise. Fan over-ride purges unit of residual heat at shutdown.

### LOUVER ASSEMBLY:

Louvers are individually adjustable for directional control of air flow up to 15° from straight horizontal. Optional diffusers available for down flow (vertical discharge) applications.

### TEMPERATURE CONTROLS:

Optional low voltage and line voltage thermostats available with an adjustable temperature range of 40°F to 90°F. Units with model numbers ending in CA1 are factory wired for low voltage controls. 25 KW through 50 KW units are designed for two stage heating operation.

### INSTALLATION:

Unit Heaters can be mounted for horizontal or vertical discharge. Applications up to 6000 Ft. See UH Series above 6000 Ft. ABS (American Bureau of Shipping) type approved.

### Taskmaster Dimensions

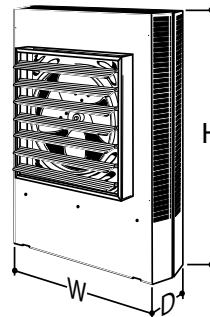

KW RATING	DIMENSIONS (inches)		
	H	W	D
3.3 - 5.0	17 3/4	14 15/32	6 1/2
7.5 - 10.0	24 5/16	21 1/2	6 1/2
15.0 - 20.0	28 11/16	21 1/2	6 1/2
25.0 - 50.0	34	29 1/4	10 1/16

## Installing the Taskmaster Series

### DETERMINING HEATER REQUIREMENTS

Calculate the heating loads using the NEMA handbook or ASHRAE guide. Then determine the quantity and size of unit heaters to be used. To maintain uniform heat and reduce stratified air, it is recommended that the total CFM of the units turn the air over approximately 3 times per hour. In instances where a large group of people are located and normally in the same area, use a large number of lower KW unit heaters. In warehouse areas or storage rooms where heat distribution and constant temperatures are less important, use fewer heaters of higher capacity.

### HORIZONTAL MOUNT

Small rooms can be heated by one unit heater. Where two walls are exposed, heaters should be mounted as shown in Figure A. In larger rooms, units should be located so their air streams wipe exposed walls without blowing at them. Units should be located so that the air stream of one supports that of another thus setting up a circulatory air movement shown in Figure B. (Distance between units to be approximately 1-1/2 times published air throw.) Units should not be mounted horizontally in areas having ceiling heights in excess of 15-18 ft.



Figure A

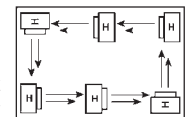

Figure B

### VERTICAL MOUNT

Units should be mounted vertically in high bay areas, or where heater location would not interfere with plant operation or traffic. Heaters should be situated to provide free air circulation. Size and selection of units should be based on recommended mounting height. Optional diffusers may best be employed to reduce high air velocity and at the same time disperse heated air in a uniform pattern. When unit heaters are used to combat cold air inrush from opened loading dock doors, one or more units should be arranged to blow warm air across opening (Figure C).

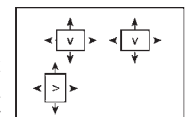

Figure C

### DUAL MOUNTING

Where square footage is large and comfort essential, both horizontal and vertical installations may best serve your requirements as Figure D demonstrates.

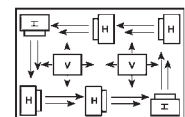
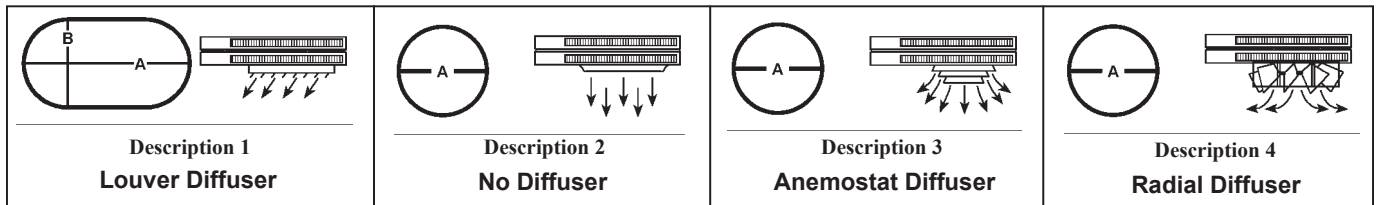

Figure D

Note: Products in this section with factory installed controls are subject to 100% cancellation/restocking charges.

## Diffuser Options

DESCRIPTION		UPC# 686334	MODEL NUMBER	KW USED	MAX MOUNTING HEIGHT (ft.)	DIMENSION A (feet)		DIMENSION B (feet)	WT. (lbs.)					
1	Louver Diffuser (Standard). Louvers can be individually adjusted for rectangular coverage over doorways as an air curtain, or to meet rectangular floor pattern heating requirements.	NA	Standard	3.3-5 7.5-10 25-30 40-50	9	20	10	NA						
					12	40	22							
					18	52	30							
					22	75	42							
					24	84	47							
2	General Distribution (No Diffuser). The 5100 air chute venturi permits general down flow air pattern distribution as required at a higher mounting height.	NA	Not Required	3.3-5 7.5-10 25-30 40-50	9	15	NA	NA						
					12	30								
					18	40								
					22	55								
					24	64								
3	Anemostat Diffuser (Optional). For applications where draft restriction is required at lower unit mounting heights.	692687	AD5120	7.5-10	15	38	NA	10						
		681186	AD5150	25-30	17	50		12						
		681186	AD5150	40-50	20	60		37						
		722070	AD5175	60-70	31	-								
4	Radial Diffuser (Optional). Individually adjustable fins permit increased floor coverage at 45° open. Additional throw is accomplished when fins are 90° vertical. (Please allow for higher mounting heights.)	692663 692663 692670 692670 722087	RD5120 RD5120 RD5150 RD5150 RD5175	7.5-20 25-50 60-70	45°	90°	45°	90°	NA	12				
					10	14	36	30						
					14	21	42	35						
					20	30	62	44						
					18	28	68	54						
					26	36	72	60						



## Mounting Brackets & Model Designator

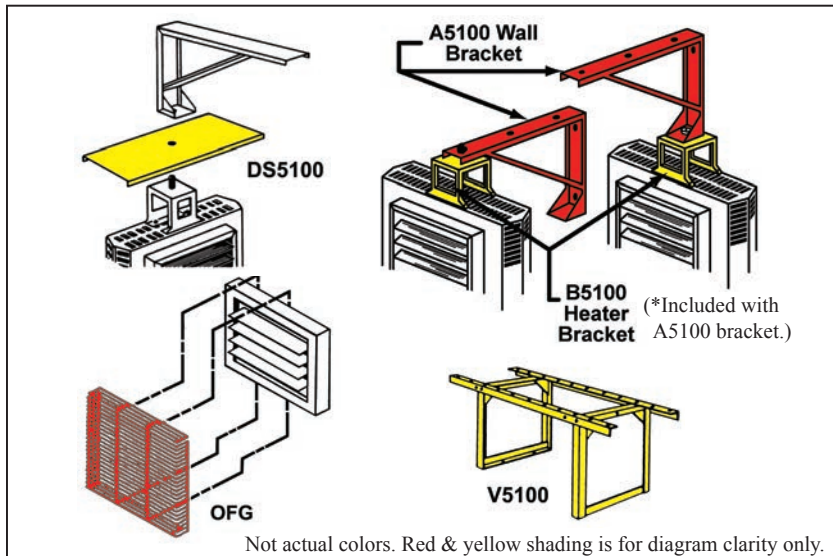

MOUNTING BRACKETS			
UPC#	MODEL	MODEL SIZE	WT.
686334			
692694	A5105	3.3 KW TO 5.0 KW	9 lbs.
692700	A5120	7.5 KW TO 20.0 KW	13 lbs.
692717	A5150	25.0 KW TO 50.0 KW	16 lbs.
688628	B5105*	3.3 KW TO 20.0 KW	3 lbs.
688635	B5150*	25.0 KW TO 50.0 KW	8 lbs.
692847	V5105	3.3 KW TO 5.0 KW	9 lbs.
692854	V5120	7.5 KW TO 20.0 KW	13 lbs.
692861	V5150	25.0 KW TO 50.0 KW	16 lbs.
DUST SHIELD			
692878	DS5105	3.3 KW TO 5.0 KW	3 lbs.
692885	DS5120	7.5 KW TO 20.0 KW	4 lbs.
681223	DS5150	25.0 KW TO 50.0 KW	5 lbs.
FAN GUARD			
706544	OFG5101	3.3 KW TO 5.0 KW	3 lbs.
706551	OFG5102	7.5 KW TO 20.0 KW	4 lbs.
706568	OFG5103	25.0 KW TO 50.0 KW	5 lbs.

### HOW TO DESIGNATE A MODEL:

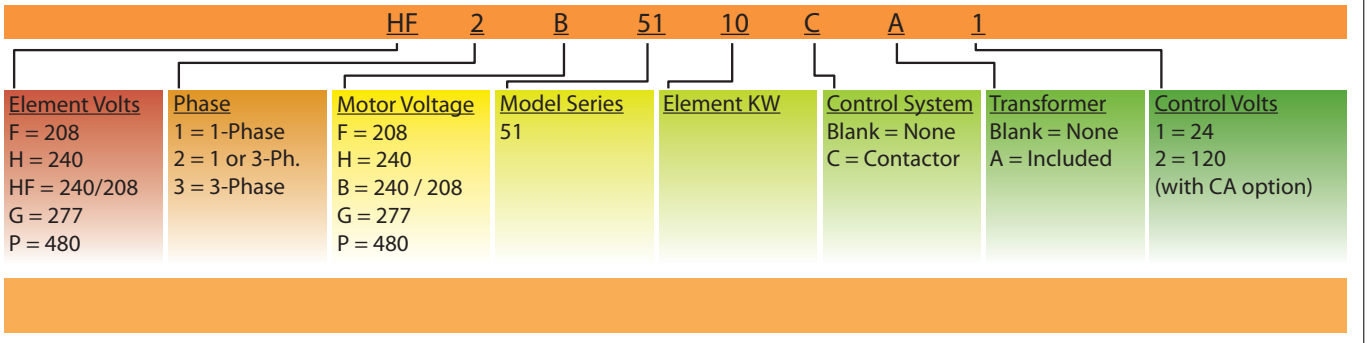



# 5100 Series Horizontal or Vertical Mounted Fan Forced Unit Heater

## Standard Taskmaster Models & Series Notes

UPC# 686334	MODEL	KW	BTU / H	VOLTS	PH	AMPS	CONTROL VOLTAGE	TEMP RISE	AIR THROW	CFM	RECOMMENDED MOUNTING HT.		WT. (LBS.)						
											Horizontal	Vertical							
645089	F1F5103N	3.3	11.2	208	1	15.9	208	26°F	12'	400	9'	9'	25						
645102	HF1B5103N	3.3/2.5	11.2 / 8.5	240/208	1	13.7 / 11.9	240 / 208												
645683	F2F5103N	3.3	11.2	208	1/3	11.9 / 6.9	208												
645706	HF2B5103N	3.3/2.5	11.2 / 8.5	240/208	1/3	13.7 / 11.9	240 / 208												
645720	G1G5103N	3.3	11.2	277	1	11.9	277												
645126	P3P5103CA1N			480	3	4.0	24												
645546	F1F5105N			208	1	24.1	208												
645560	HF1B5105N	5.0/3.7	17.1 / 12.8	240/208	1	20.9 / 18.1	240 / 208							40°F	12'	400	9'	9'	25
645140	F2F5105N	5.0	17.1	208	1/3	24.1	208												
645164	HF2B5105N	5.0	17.1	240	1/3	20.8 / 18.1	240												
645843	G1G5105N	3.7	12.8	208	1/3	12.1 / 10.4	208												
645188	P3P5105CA1N	5.0	17.1	480	3	6.1	24												
645201	F2F5107CA1L	7.5	25.6	208	1/3	36.1 / 20.8	24	34°F	22'	700	10'	12'	54						
645225	HF2B5107CA1L	7.5	25.6	240	1/3	27.1 / 31.3													
645928	G1G5107CA1L	5.6	19.2	208	1/3	31.3 / 27.1													
645249	P3P5107CA1N	7.5	25.6	277	1	27.1													
645263	F2F5110CA1L	7.5	25.6	480	3	9.1													
645287	HF2B5110CA1L	9.9	33.8	208	1/3	47.8 / 27.4													
645645	G1G5110CA1N	10.0	34.1	240	1/3	41.2 / 24.0													
645300	P3P5110CA1N	7.5	25.6	208	1/3	36.1 / 20.8													
645324	F3F5115CA1L	10.0	34.1	277	1	36.1													
645348	HF3B5115CA1L	10.0	34.1	480	3	12.1													
645362	P3P5115CA1N	15.0	51.2	208	3	41.7													
645386	HF3B5120CA1L	15.0/11.2	51.2 / 38.4	240/208	3	36.1 / 31.3													
645409	P3P5120CA1N	15.0	51.2	480	3	18.1													
645881	F3F5125CA1L	19.7/14.8	67.2 / 50.5	240/208	3	47.8 / 41.1													
645942	HF3B5125CA1L	20.0	68.3	480	3	24.1													
645980	P3P5125CA1N	25.0	85.3	208	3	69.5													
645423	F3F5130CA1L	25.0/18.7	85.3 / 64.0	240/208	3	60.2 / 52.1													
645447	HF3B5130CA1L	25.0	85.3	480	3	30.1													
645461	P3P5130CA1N	30.0	102.4	208	3	83.4													
644044	F3F5140CA1L	30.0/22.5	102.4 / 76.8	240/208	3	72.3 / 62.5													
644068	HF3B5140CA1L	30.0	102.4	480	3	36.2													
644082	P3P5140CA1N	40.0	136.5	208	3	111.2													
645485	F3F5150CA1L	40.0/30.0	136.5 / 102.4	240/208	3	96.4 / 83.4													
645508	HF3B5150CA1L	39.0	133.1	480	3	47.0													
645522	P3P5150CA1N	49.6	169.3	208	3	139.0													
		50.0/37.5	170.6 / 128.0	240/208	3	120.5 / 104.3													
		50.0	170.6	480	3	60.3													

## International Models

UPC# 686334	MODEL	KW	BTU/H	VOLTS	PH	AMPS	CONTROL VOLTAGE	TEMP RISE	AIR THROW	CFM	RECOMMENDED MOUNTING HT.		WT. (LBS.)
											Horizontal	Vertical	
715300	Q3H5103CA1	3.3	11263	380	3	5.02	24	26	12'	400	9'	9'	25
724920	R3H5103CA1			415		4.6							
724937	Q3H5105CA1			380		7.6							
424944	R3H5105CA1	5.0	17065	415	3	6.96	24	40	12'	400	9'	9'	27
717137	Q3H5107CA1			380		11.4							
724951	R3H5107CA1			415		10.5							
686570	Q3H5110CA1	7.5	25600	380	3	15.2	24	34	22'	700	10'	12'	54
724968	R3H5110CA1			415		13.9							
724975	Q3H5115CA1			380		22.8							
724982	R3H5115CA1	15.0	51195	415	3	20.9	24	43	32'	1100	11'	20'	64
704175	Q3H5120CA1			380		30.4							
724999	R3H5120CA1			415		27.85							
719193	Q3H5125CA1	25.0	85325	380	3	38.0	24	40/44	45'	2000/1800	12'	22'	120
710619	R3H5125CA1			415		34.8							
725002	Q3H5130CA1			380		45.6							
710626	R3H5130CA1	30.0	102390	415	3	41.8	24	47/53	40'	2000/1800	12'	20'	120
725019	Q3H5140CA1			380		60.85							
709835	R3H5140CA1			415		55.7							
		40.0	136520	380	3	60.85	24	40/45	55'	3100/2800	15'	24'	120

• For 24V control add "CA1" suffix. • For 120V control add "CA2" suffix. • For other voltages consult factory.

### NOTES:

- 25-50KW models are wired for single or two stage heating and have two speed motors.
- Air delivery and motor data on dual voltage units reflect higher voltage.
- 600 Volt models available in 5 KW through 30 KW. Contact factory for delivery.
- Supply wire on 40 and 50 KW models should have rated insulation of 75°C minimum.
- Use T5122 for two stage control.
- Use TW123 for two stage control.
- Use TFS5102 for two stage control.
- Wall thermostat must be used when built-in stratification thermostat is required.

# 5100 Series Horizontal or Vertical Mounted Fan Forced Unit Heater

## Recommended Control Options, Control Accessory Options, & Control Accessories

MODEL NUMBER	DISCONNECT SWITCH		THERMOSTAT		SUMMER FAN SWITCH		THERMOSTAT & SUMMER FAN SWITCH WALL MOUNTED	STRATIFICATION THERMOSTAT	
	1 Ø	3 Ø	IN-BUILT	WALL MOUNTED	IN-BUILT	WALL MOUNTED		IN-BUILT	WALL MOUNTED
F1F5103N	DCS 202	NA	T5100	ET5SS	FS5101	FSW5111	NA	TC5103	TC1602
HF1B5103N									
F2F5103N	NA	DCS 403	T5102	TW 1512	FS5101	FSW5111	NA	TC5103	TC1602
HF2B5103N	DCS 202	NA	T5100	ET 5SS					
G1G5103N	DCS 202	NA	T5100	ET5SS	FS5102	FSW5112	TFS5101	TC5102	NA
P3P5103CA1N	NA	DCS 403		A6176					
F1F5105N	DCS 403	NA	T5102	S2025	FS5101	FSW5111	NA	TC5103	TC1602
HF1B5105N				ET5SS					
F2F5105N	NA	DCS 403	T5102	TW 1512	FS5101	FSW5111	NA	TC5103	TC1602
HF2B5105N	DCS 403	NA	T5100	ET5SS					
G1G5105N	DCS 202	NA	T5100	S2025	FS5102	FSW5112	TFS5101	TC5102	NA
P3P5105CA1N	NA	DCS 403		A6176 OR TW123					
F2F5107CA1L	DCS 403	NA	T5100	A6176 OR TW123	FS5101	FSW5111	TFS5101	TC5103	TC1602
HF2B5107CA1L	DCS 403	NA							
G1G5107CA1L	DCS 403	NA	T5100	A6176 OR TW123	FS5102	FSW5112	TFS5101	TC5102	NA
P3P5107CA1L	NA	DCS 403							
F2F5110CA1L	DCS 603	NA	T5100	A6176 OR TW123	FS5101	FSW5111	TFS5101	TC5103	TC1602
HF2B5110CA1L	DCS 603	NA							
G1G5110CA1N	DCS 403	NA	T5100	A6176 OR TW123	FS5101	FSW5111	TFS5101	TC5103	TC1602
P3P5110CA1N	DCS 403	NA							
F3F5115CA1L	DCS 603	NA	T5100	A6176 OR TW123	FS5102	FSW5112	TFS5101	TC5103	TC1602
HF3B5115CA1L	DCS 403	NA							
P3P5115CA1L	DCS 403	NA	T5100	A6176 OR TW123	FS5101	FSW5111	TFS5101	TC5103	TC1602
HF3B5120CA1L	DCS 603	NA							
P3P5120CA1N	DCS 403	NA	T5100	A6176 OR TW123	FS5102	FSW5112	TFS5101	TC5103	TC1602
F3F5125CA1L	DCS 1003	NA							
HF3B5125CA1L	DCS 403	NA	T5100	A6176 OR TW123	FS5101	FSW5111	TFS5101	TC5103	TC1602
P3P5125CA1N	DCS 403	NA							
F3F5130CA1L	DCS 1003	NA	T5100	A6176 OR TW123	FS5102	FSW5112	TFS5101	TC5103	TC1602
HF3B5130CA1L	DCS 1003	NA							
P3P5130CA1N	DCS 403	NA	T5100	A6176 OR TW123	FS5101	FSW5111	TFS5101	TC5103	TC1602
F3F5140CA1L	DCS 403	NA							
HF3B5140CA1L	DCS 403	NA	T5100	A6176 OR TW123	FS5101	FSW5111	TFS5101	TC5103	TC1602
P3P5140CA1N	DCS 603	NA							
F3F5150CA1L	DCS 603	NA	T5100	A6176 OR TW123	FS5102	FSW5112	TFS5101	TC5103	TC1602
HF3B5150CA1L	DCS 603	NA							
P3P5150CA1N	DCS 1003	NA	T5100	A6176 OR TW123	FS5101	FSW5111	TFS5101	TC5103	TC1602

CONTROL ACCESSORY OPTIONS - FIELD INSTALLED IN HEATER		
UPC#	MODEL	DESCRIPTION
686334		
<b>POWER DISCONNECT SWITCH</b>		
717151	DCS202/5100	2 POLE; 20 AMP; 120-277 V.A.C.
717168	DCS403/5100	3 POLE; 40 AMP; 120-600 V.A.C.
717175	DCS603/5100	3 POLE; 60 AMP; 120-600 V.A.C.
717182	DCS1003/5100	3 POLE; 100 AMP; 120-600 V.A.C.
<b>LINE VOLTAGE THERMOSTAT (45 - 90 °F)</b>		
692779	T5100	SPST; LINE DUTY 25 AMP 120-277V
692786	T5102	DPST; LINE DUTY 25 AMP 120-277V
<b>LOW VOLTAGE THERMOSTAT (ALL CA1 MODELS) (45 - 90 °F)</b>		
692779	T5100	SPST; LOW VOLT/PILOT DUTY; 125VA; (3.3-20 KW UNITS)
692793	T5122	2-STAGE; LOW VOLT; 125VA; (25-50 KW UNITS)
<b>STRATIFICATION THERMOSTAT</b>		
692809	TC5102	SPST; LOW VOLT/PILOT DUTY (W/RELAY) ; 70-130°
692816	TC5103	SPST; LINE DUTY; AMP 120-240V; 70-130°
<b>SUMMER FAN SWITCH</b>		
692823	FS5101	SPST; LINE VOLT ;120-277V
692830	FS5102	SPST; LINE VOLT ; 480-600V

CONTROL ACCESSORIES - REMOTE WALL MOUNTED		
UPC#	MODEL	DESCRIPTION
686334		
<b>LINE VOLTAGE THERMOSTAT</b>		
691086	**TW1510	SPST; 25 AMP 120-277V 50-90°
691093	*TW1512	DPST; 25 AMP 120-277V 50-90°
<b>LOW VOLTAGE THERMOSTAT (ALL CA1 MODELS)</b>		
260008	A6176	SPST; (3.3 - 20 KW UNITS) 50-90°
691116	TW123	2STAGE; (25 - 50 KW UNITS) 40-90°
<b>STRATIFICATION THERMOSTAT</b>		
691109	TC1602	LINE VOLT 120-277V 70-140°
<b>SUMMER FAN SWITCH</b>		
692625	FSW5111	SPST; LINE VOLT 120-277V
692632	FSW5112	SPST; LOW VOLT (W/RELAY)
<b>LOW VOLTAGE T*STAT &amp; SUMMER FAN SWITCH(W/RELAY) (CA1 MODELS)</b>		
692649	TFS5101	SPST; LOW VOLT 50-90°
692502	TFS5102	2 STAGE; LOW VOLT 50-90°

\*\* Any SPST thermostat of sufficient amperage may be substituted.  
\*Use DPST thermostat for 3-phase line voltage control in non "C" models.



## Features & Specifications

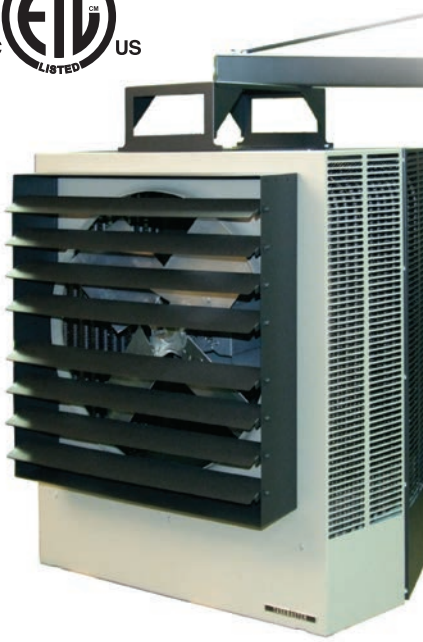

Manufactured in U.S.A.

### CONSTRUCTION:

Heavy gauge steel cabinet with powder coated finish and control compartment housing a master terminal board. The control compartment allows for access through a hinged and latched door, simplifying wiring, installation, and maintenance.

### HEATING ELEMENT:

The heating element is a copper clad steel sheath element with continuously brazed steel fins formed to allow side draw through air flow.

### OVERHEAT PROTECTION:

All units come equipped with manual reset type limit controls to de-energize the heater should an over-temperature situation occur.

### FAN & MOTOR:

Single speed, single phase permanently lubricated, thermally protected motors with ball bearings. The fan override purges the unit of residual heat at shutdown.

### FIELD INSTALLED OPTIONS:

Summer fan switch to operate the fan only, and a heat stratification thermostat for high bay areas.

### HEATER STAGING:

60 KW and 70 KW are three stage; 80 KW, 90 KW, & 100 KW are four stage.

### SC5100 FACTORY INSTALLED ELECTRONIC STEP CONTROLLER:

The optional factory installed step controller is a first on last off sequencer that will cycle the unit heater stages through an optional wall thermostat. Additionally, the step controller can be controlled by any building management system with 4 to 20 MA or 0 - 10 VDC field supplied control signal.

## Optional Factory Installed Electronic Step Controller

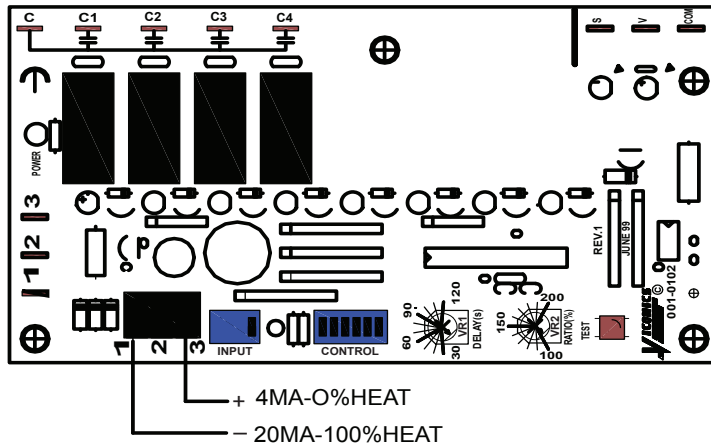

3 OR 4 STAGE  
STEP CONTROL

0-10VDC-CONTROL  
OR C1025 WALL  
THERMOSTAT

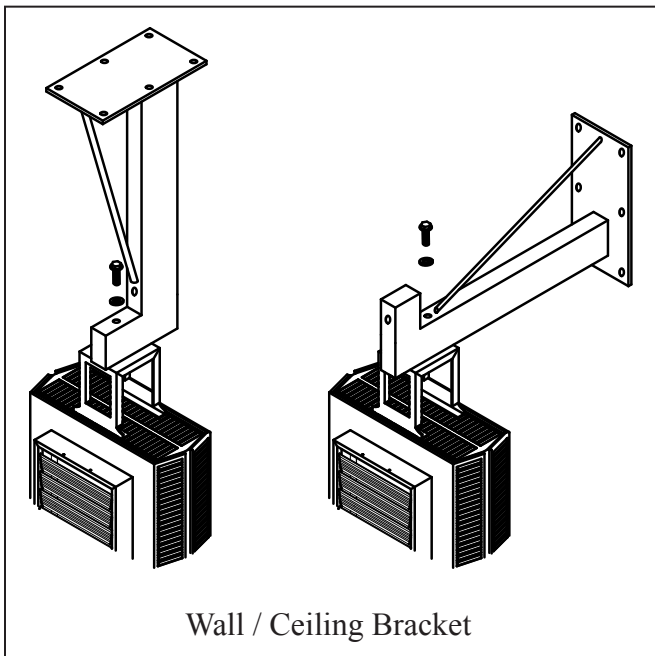

Wall / Ceiling Bracket

## Dimensions

Dimensions (Inches)				WT (LBS.)
KW	H	W	D	
60-70	35 1/2	30 1/2	14 1/2	141
80-100	39 1/2	37 5/8	18 1/2	202

## Mounting Brackets and Accessories

Mounting Brackets			
UPC#	Model	Heater KW	Description
686334			
7220002	A5175	60 To 70	Wall/Ceiling Bracket
7220102	A51100	80 to 100	
7220302	B5175	60 to 70	Heater Bracket
7220402	B51100	80 to 100	
7220202	V51100	60 to 100	Vertical Bracket
7220502	DS5175	60 to 70	Dust Shield
7220602	DS51100	80 to 100	
7220902	OFG 5175	60 to 70	Fan Guard
7221002	OFG 51100	80 to 100	



# 5100 Series 60 KW - 100 KW Suspended Fan Forced Unit Heater

## Electrical Data

UPC# 686334	Catalog Number	KW	BTU/HR (x 1000)	Voltage	Phase	Control Voltage	Amps / Phase	Branch Circuit Protection Size
721349	F3F5160CA1	60	204.7	208	3	24	166.7	225
721356	HF3B5160CA1	60/45	204.7/153.6	240/208			144.6/125	200/175
721363	P3P5160CA1	60	204.7	480			72.3	100
721424	F3F5170CA1	70	238.9	208	3	24	194.4	250
721431	HF3B5170CA1	70/52.5	238.9/179.2	240/208			168.7/145.8	225/200
721448	P3P5170CA1	70	238.9	480			84.3	110
721707	HF3B5180CA1	80/60	273/204.7	240/208	3	24	192.8/166.7	250/225
721714	P3P5180CA1	80	273	480			96.3	125
721769	HF3B5190CA1	90/67.5	307.1/230.4	240/208	3	24	216.9/187.5	300/250
721776	P3P5190CA1	90	307.1	480			108.4	150
721820	HF3B51100CA1	100/75	341.3/256	240/208	3	24	241/208.3	350/300
721837	P3P51100CA1	100	341.3	480			120.4	175

## Air Delivery Data

UPC# 686334	Catalog Number	CFM at Outlet	FPM at Outlet	Temp Rise °F	HP	Motor RPM	Air Throw	Max Mounting	
								Horizontal	Vertical
721349	F3F5160CA1	3400	1485	60	1/3	1100	50'	18'	31'
721356	HF3B5160CA1			60/45					
721363	P3P5160CA1			60					
721424	F3F5170CA1			70					
721431	HF3B5170CA1			70/53					
721448	P3P5170CA1			70					
721707	HF3B5180CA1	5000	1529	55/41	3/4	1100	65'	22'	40'
721714	P3P5180CA1			55					
721769	HF3B5190CA1			61/46					
721776	P3P5190CA1			61					
721820	HF3B51100CA1			68/51					
721837	P3P51100CA1			68					

## Recommended Control Options

UPC# 686334	Catalog Number	Step Controller	Thermostat	Summer Fan Switch		Stratification Thermostat		
				Wall	Built-In	Wall	Built-In	
721349	F3F5160CA1	SC5100	C1025	FSW5112		FS5101	TFS5101	TC5102
721356	HF3B5160CA1				FS5101			
721363	P3P5160CA1				FS5102			
721424	F3F5170CA1				FS5101			
721431	HF3B5170CA1				FS5101			
721448	P3P5170CA1				FS5102			
721707	HF3B5180CA1				FS5101			
721714	P3P5180CA1				FS5102			
721769	HF3B5190CA1				FS5101			
721776	P3P5190CA1				FS5102			
721820	HF3B51100CA1				FS5101			
721837	P3P51100CA1				FS5102			

# 2600 Series Downflow Unit Heater

## General Description & Diffuser Information

### CONSTRUCTION:

- 16 gauge steel cabinet with epoxy powder coated finish and control compartment with a hinged and latched access door.
- OSHA guards standard with all models.

### HEATING ELEMENT:

- Corrosion resistant element with steel sheath and steel spiral fins.

### OVERHEAT PROTECTION:

- All units come equipped with manual reset limit controls to de-energize the heater should an over-temperature situation occur.

### FAN and MOTOR:

- Totally enclosed, 1 speed, 1 phase permanently lubricated, thermally protected motors with unit bearings on 3KW - 20KW models. Totally enclosed, 2 speed, 1 phase permanently lubricated, thermally protected motors with sleeve bearings on 24KW - 50KW models.
- Axial flow fan blade - 1570 RPM max.
- All models equipped with fan purge which allows fan to operate after elements are de-energized to purge residual heat.

### TEMPERATURE CONTROLS:

- 208V, 240V, 277V and 480V units have In-Built 24 Volt transformer for low voltage remote thermostat application.
- 600V units have In-Built 240V control on 5-20 KW models, 25-50 KW models have 24V control.
- 25 KW - 50 KW models may operate as 2 stage heaters if 2 stage remote thermostat is used.

### DISCONNECT SWITCH:

- All models equipped with In-Built disconnect except F3F2640, F3F2650 and H3H2650.

### INSTALLATION:

- Unit can be mounted using optional mounting bracket or field constructed angle iron bracket.
- Not recommended for mounting with threaded rod or chain.

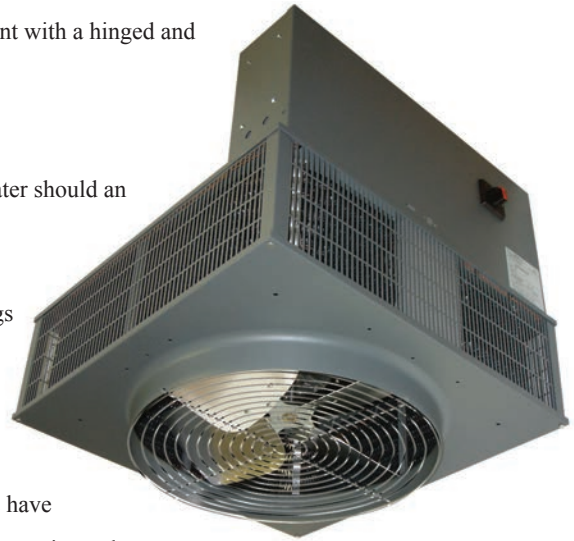

Manufactured in U.S.A.

2600 Series shown with standard wire guard. Diffusers are field installed.

Diffuser Descriptions	Standard Heater			Radial Louvered Cone Diffuser			Linear Louvered Diffuser			Anemostat Diffuser														
	<table border="1"> <thead> <tr> <th colspan="3">Dimensions**</th> </tr> <tr> <th>KW</th> <th>B</th> <th>A</th> </tr> </thead> <tbody> <tr> <td>5-20</td> <td>20 1/2"</td> <td>15"</td> </tr> <tr> <td>25-50</td> <td>27"</td> <td>21 1/2"</td> </tr> </tbody> </table>			Dimensions**			KW	B	A	5-20	20 1/2"	15"	25-50	27"	21 1/2"									
	Dimensions**																							
KW	B	A																						
5-20	20 1/2"	15"																						
25-50	27"	21 1/2"																						
<p>For general distribution. Choice of other diffusers may be added after installation if required.</p> <p>O.S.H.A guard for fan blade D1604 for 2605-2620, &amp; D1614 for 2625-2650 Do not use with other diffusers.</p>			<p>With vanes vertical, straightens air for higher mounting. Closed position for broad horizontal coverage. Adjustable for intermediate requirements.</p>			<p>Affords more precise directional throw where heaters cannot be mounted directly over area to be heated or for heating long narrow areas.</p>			<p>Blends room air with heated air for widespread distribution without excessive drafts.</p>															
			VERTICAL			45 DEGREES OPEN																		
MODEL	MAX MOUNTING HEIGHT*	D (ft.)	MAX MOUNTING HEIGHT	D (ft.)	MAX MOUNTING HEIGHT	D (ft.)	MAX MOUNTING HEIGHT	W (ft.)	L (ft.)	MAX MOUNTING HEIGHT	D (ft.)													
2605	10	25	15	25	8	30	10	10	40	9	25													
2607	10	25	15	25	8	30	10	10	40	9	25													
2610	22	40	26	36	15	44	22	14	54	20	38													
2615	20	44	24	38	14	46	20	14	60	18	40													
2620	18	48	22	40	13	50	18	15	66	16	42													
2625	32	48	38	42	24	70	34	30	80	30	60													
2630	30	60	36	50	22	74	32	34	80	28	64													
2640	26	64	32	50	20	78	30	36	90	26	67													
2650	24	68	28	50	18	82	28	40	100	24	70													

\*Minimum mounting height 6 feet.

\*\*Dimensions are for all heater models without a diffuser option. Adding a diffuser will change the vertical ("A") dimension of heater. All mounting distances are in feet. All diagrams show optional mounting bracket.

# 2600 Series Downflow Unit Heater

## Product Specifications

**SPECIFICATIONS:** The contractor shall furnish and install the 2600 Series electric vertical discharge unit heaters of the size, capacity and voltage specified. Heaters shall be installed according to the manufacturer's recommendations and applicable national and local codes.

**ELEMENTS:** Elements shall consist of Nickel Chromium alloy resistance wire embedded and completely surrounded in Magnesium Oxide, enclosed and swagged into corrosion resistant sheaths. Corrosion resistant steel fins shall be permanently attached to the sheaths to provide maximum heat transfer to the air stream.

**MOTORS:** Motors shall be single phase, resilient mounted, totally enclosed, industrial rated with an automatic reset thermal overload protective device. Motors on heaters up to 20 KW capacity shall be permanently lubricated shaded pole type. Over 20 KW, motors shall be permanent split capacitor type. Motors shall be mounted out of the main air stream in such a manner as to allow ambient air to be drawn over the motor to reduce motor temperature. Motor shall be separately removable from beneath the heater without removing the entire heater from mounting bracket.

**FAN BLADES:** Fan blades shall be heavy-duty individually balanced axial flow type. Fan speed shall not exceed 1570 RPM.

**THERMAL OVERLOAD PROTECTION:** All heaters shall be equipped with a manual reset thermal cutout which disconnects elements and motor in the event normal operating temperatures are exceeded.

**WIRING:** Heaters shall be designed for a single supply circuit with elements, motor and control circuits subdivided and fused to conform with the latest National Electric Code and OSHA requirements. All three phase heaters shall have balanced phases.

**CONTROLS:** Heaters shall be controlled by a low voltage wall mounted thermostat. All heaters 25 KW and larger shall be wired for 2 stage operation. 5 KW through 20 KW units are single stage. All heaters shall be equipped with a fan safety device that causes fan to operate after elements are de-energized to purge unit of residual heat.

## Standard Models

UPC# 686334	MODEL	KW	BTU's	VOLTS	PH	AMPS	CONTROL VOLTS	TEMP RISE °F	CFM	WT (LBS.)
715751	F1F2605CA1	5	17065	208	1	24.03	24	34	490	75
715768	H1H2605CA1			240		20.83				
715775	G1G2605CA1			277		18.05				
715782	F3F2605CA1			208	3	13.89				
715799	H3H2605CA1			240		12.04				
715805	P3P2605CA1			480		6.02				
715812	U3H2605CA4			600		4.81				
715829	F1F2607CA1	7.5	25598	208	1	36.05	24	45	560	75
715836	H1H2607CA1			240		31.25				
715843	G1G2607CA1			277		27.07				
715850	F3F2607CA1			208	3	20.84				
715867	H3H2607CA1			240		18.06				
715874	P3P2607CA1			480		9.03				
715881	U3H2607CA4			600		7.22				
715898	F1F2610CA1	10	34130	208	1	48.07	24	26	1200	75
715904	H1H2610CA1			240		41.66				
715911	G1G2610CA1			277		36.1				
715928	F3F2610CA1			208	3	27.79				
715935	H3H2610CA1			240		24.08				
715942	P3P2610CA1			480		12.04				
715959	U3H2610CA4			600		9.63				
715966	F3F2615CA1	15	51195	208	3	41.68	24	39	1200	75
715973	H3H2615CA1			240		36.12				
715980	P3P2615CA1			480		18.06				
715997	U3H2615CA4			600		14.45				
716000	H3H2620CA1	19.4	68260	240	3	48.16	24	52	1200	75
716017	P3P2620CA1	20		480		24.08				
717502	U3H2620CA4			600		19.26				
717519	F3F2625CA1	25	85325	208	3	69.48	24	24	3300	175
717526	H3H2625CA1			240		60.21				
717533	P3P2625CA1			480		30.1				
717540	U3U2625CA1			600		24.08				
717557	F3F2630CA1	30	102390	208	3	83.37	24	29	3300	175
717564	H3H2630CA1			240		72.25				
717571	P3P2630CA1			480		36.12				
717588	U3U2630CA1			600		28.9				
717595	F3F2640CA1	40	136520	208	3	111.17	24	38	3300	175
717601	H3H2640CA1			240		96.33				
717618	P3P2640CA1			480		48.16				
717625	U3U2640CA1			600		38.53				
717632	F3F2650CA1	50	170650	208	3	138.96	24	48	3300	175
717649	H3H2650CA1			240		120.42				
717656	P3P2650CA1			480		60.21				
717663	U3U2650CA1			600		48.16				



# 2600 Series Downflow Unit Heater

## Field Installed Accessories

UPC# 686334	MODEL	DESCRIPTION
692632	FSW5112	Summer Fan Switch
691109	TC1602	Wall Mounted Stratification Thermostat Range - 70 °F - 140 °F
717755	A1600	Ceiling Mount Bracket 5-20 KW Models
717762	A1601	Ceiling Mount Bracket 25-50 KW Models

UPC# 686334	MODEL	DESCRIPTION
717793	D1602	Linear Louvered Diffuser 5-20 KW Models
717809	D1612	Linear Louvered Diffuser 25-50 KW Models
717816	D1600	Radial Louvered Cone Diffuser 5-20 KW Models
717823	D1610	Radial Louvered Cone Diffuser 25-50 KW Models
717830	D1603	Anemostat Diffuser 5-20 KW Models
717847	D1613	Anemostat Diffuser 25-50 KW Models

## 5700 Series Confined Space Plenum Rated Heater



### Features

- Easily fits between joists for typical installation.
- Zero clearance for wall and ceiling mounting as well as floor mounting with appropriate inlet and outlet clearances.
- Bracket standard or can be mounted by 3/8" threaded rod (field supplied)
- Automatic reset thermal limit for safety
- 1 Phase model wattage field changeable from 1874 to 5000 Watts.
- 24V control circuit on three phase models with hydraulic thermostat

Conforms to ANSI/UL 1995

Certified to CAN/CSA C 22.2 No.236-11

### Product Dimensions

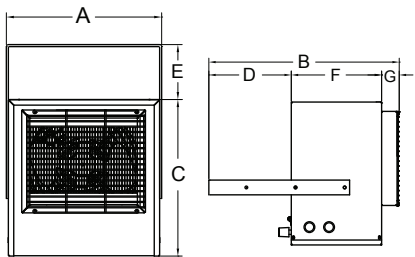

A	B	C	D	E	F	G
14.4"	19.4"	14.5"	8.4"	5.1"	9.2"	1.8"

### Standard Models

UPC# 686334	MODEL	WATTS	BTU's	VOLTS	PHASE	AMPS	TEMP RISE	AIR THROW	CFM	WT. (LBS.)		
726245	HF5705T	5000	17065	240	1	21	57 °F	16'	275	32		
		4165	14215			17	48 °F					
		3332	11365			14	38 °F					
		727252	H3H5705T	2500	8533	208	1	10	29 °F	16'	275	32
				3750	12798			18	43 °F			
				3123	10659			15	36 °F			
726269	P3P5705T	2500	8553	480	3	12	29 °F	16'	275	32		
707367	DCS-MT303	1874	6396			9	21 °F					
727252	H3H5705T	3750	12799	208	3	10.4	57 °F	16'	375	32		
		5000	17065	240	3	12	57 °F	16'	275	32		
726269	P3P5705T	5000	17065	480	3	6	57 °F	16'	275	32		
707367	DCS-MT303	Optional Field Installed Disconnect Switch, 30 Amp @ 600Volts										
For 24V control on single phase models delete "T" suffix												

## Product Specifications

**CASING:** Fabricated of die formed, heavy gauge steel and finished with two tone, brown and beige, durable powder coated paint. Supply air is drawn through the rear heavy duty expanded steel inlet grill. Heated air is discharged through front adjustable louvers, which are spring loaded for individual adjustment.

**ELEMENT:** Heavy-duty block fin element design. The multiple tap electric connection design allows field conversion to eight wattage settings at 208/240-Volt single phase or 240/480 Volt, 3 phase. Units are available on special order with a specific wattage/voltage setting.

**MOTOR:** Motor shall be totally enclosed, permanently lubricated, all angle industrial rated with thermal overload protection.

**WIRING:** Wiring to terminal block adjacent to incoming knockout in accordance with NEC and local codes.

**THERMAL OVERLOAD:** All heaters shall be equipped with an automatic reset thermal cutout to shut down the element and motor circuits if unsafe operating temperatures are exceeded.

**CONTROLS:** The heater shall have a heavy-duty hydraulic thermostat factory installed and wired. All controls and wiring shall be in a large wiring compartment with hinged door for easy access. An optional disconnect switch shall be available for field installation.

**MOUNTING:** Heaters are standard with a three position-mounting bracket for wall, ceiling or workbench. Heaters can be mounted for horizontal or vertical discharge. Note: Minimum mounting height is 6 feet, and minimum distance from side of heater to nearest wall is 6 inches. Note: Approved for residential applications.



Front view

Manufactured in U.S.A.



## Product Dimensions

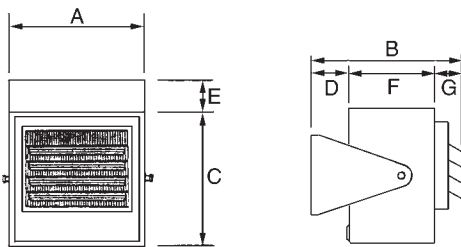

A	B	C	D	E	F	G
14"	12-11/16"	14"	1-9/16"	1-9/16"	9"	2-3/4"

## Standard Models

UPC# 686334	MODEL	WATTS	BTU's	VOLTS	PHASE	AMPS	TEMP RISE	AIR THROW	CFM	WT. (LBS.)
707282	HF5605T	5000	17065	240	1	21	57 °F	16'	275	32
		4165	14215			17	48 °F			
		3332	11365			14	38 °F			
		2500	8533			10	29 °F			
		3750	12798	208	1	18	43 °F	16'	275	32
		3123	10659			15	36 °F			
2500	8553	12	29 °F							
1874	6396	9	21 °F							
707299	H3H5605T	3750	12799	208	3	10.4	57 °F	16'	375	32
		5000	17065	240	3	12	57 °F	16'	275	32
707305	P3P5605T	5000	17065	480	3	6	57 °F	16'	275	32
707367	DCS-MT303	Optional Field Installed Disconnect Switch, 30 Amp @ 600Volts								
For 24V control on single phase models delete "T" suffix										

# 6300 Series Multiple Angle Cabinet Unit Heater

## Product Specifications

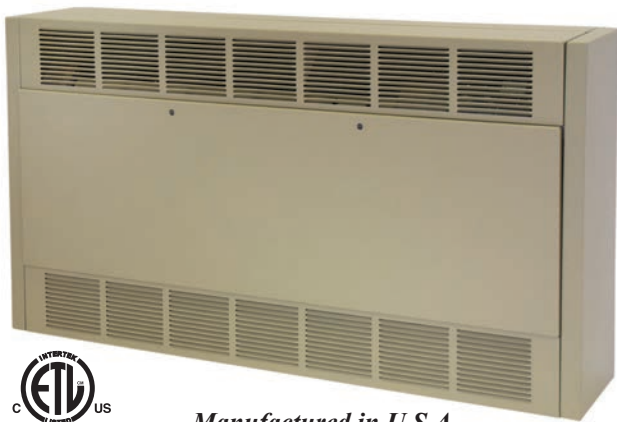

*Manufactured in U.S.A.*

The electric cabinet unit heater is designed for mounting in any position, fully recessed, semi-recessed or surface mounted. All capacities, voltages, physical sizes, grille arrangements and options shall be as specified on the plans. All units must be field convertible to the following:

1. For control by a field supplied remote thermostat.
2. Load management control with an external dry switch.  
When closed unit operates under control of either the internal or the external thermostat. When open, unit turns off.
3. Any grille arrangement.

**CABINET:** The cabinet shall be constructed of heavy duty 16 gauge Zinc coated steel. The heater shall have a removable front door for easy access to the control panel, elements, motor-blower assembly,

filters and all internal components. The grill configuration must be easily field convertible to any air flow configuration (by removal of no more than four fasteners). The cabinet shall have a textured finish of two coats of powder coat epoxy and be suitable for use with optional kick space base.

**HEATING ELEMENTS:** The heating elements shall be warranted for 1 year and shall be non-glowing design consisting of special high temperature resistance wire enclosed in an incoloy sheath to which steel fins are furnace brazed. The heating elements shall be located directly in front of the blower discharge air for uniform heating. They shall be mounted with a single anchor at one end to minimize effects of thermal expansion and contraction.

**SAFETY CUTOFF:** Thermal safety limits shall be built into the system to automatically shut off heater in event of overheating due to any cause. The safety cutouts shall be of two types:

- A. The primary limit shall be an automatic capillary type to sense the heat along the full length of the heating elements. It shall de-energize the heaters by opening the coil circuit on the heating contactors.
- B. The secondary limit shall be a manual reset thermal device to interrupt power to the heating elements.

**MOTOR AND BLOWER ASSEMBLY:** The motors and blowers shall be direct drive and resiliently mounted on rigid heavy gauge frame for quiet operation and long life. The motor shall be two-speed, shaded pole type, rated for the voltage (480 to 600 Volts are single speed only). Each shall have built-in automatic reset overload protection and are life time lubricated. The motor shall be vented and mounted in the air stream to provide maximum cooling of the motor.

**HIGH AND LOW HEAT RANGES:** All units will be supplied as standard with a switch for selecting full heat at high fan speed or reduced heat at low fan speed (On 480 & 600 Volt units the switch changes the heat but not the fan speed).

**OVER CURRENT PROTECTION:** Circuit breakers shall be provided for branch circuit protection where required by NEC. Circuit breakers are optional on all other heaters.

**TEMPERATURE CONTROL:** Integral factory installed thermostat shall be tamper resistant, linear capillary type.

## Mounting Configurations

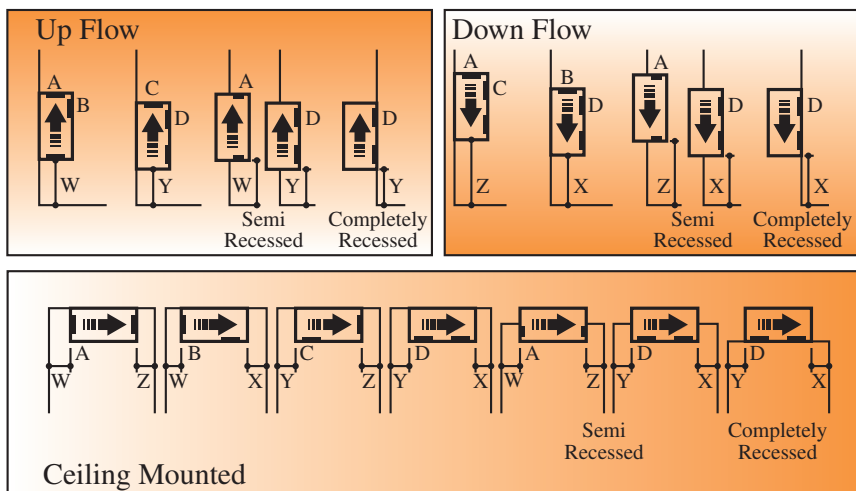

KEY: W = 6" minimum, X = 12" minimum, Y = 0" or greater, Z = 24" minimum

**NOTE:** Semi-recessed units are to be recessed at a maximum of 3 1/2" unless grill configuration is front in and front out.

**MOUNTING CLEARANCES:** Proper clearances are indicated for each mounting configuration on all positions. Minimum clearance from side of unit to the wall is zero inches. Mounting inches are provided in the back of the cabinet, accessible through the blower compartment, if necessary, remove blower deck if additional mounting screws or bolts are desired. Blower deck may be slipped forward by loosening four screws at the front to provide access to mounting holes.

# 6300 Series Multiple Angle Cabinet Unit Heater

## Product Features (2-24 KW; All Voltages)

- For commercial and institutional application such as stores, schools, offices, transportation terminals, churches, entrance ways.
- Wall or ceiling mount; surface, semi-recessed or fully recessed.
- (8) air inlet and outlet configurations.
- Capacities from 2-24 KW with 230 to 1,000 CFM
- Motors are two speed, shaded pole, resilient mounted, direct drive. High/low heat and blower speed offer versatility.
- ETL Listed.
- Beige powder coated finish
- Choice of eight standard control options include unit or wall mounted 120 or 24V thermostats, with or without built-in control transformers.
- Industrial type finned tubular elements.
- Easily removable fan and element decks for simplified maintenance.
- Full length thermal protection.
- Limited warranty-one year.

## Product Dimensions

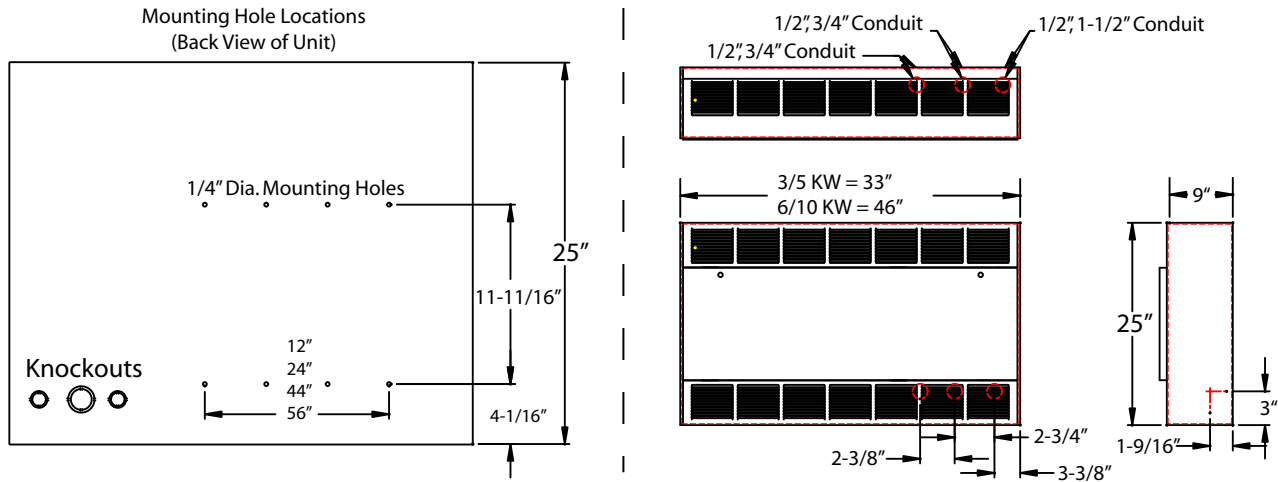

## Stocked Models & Features

HEATER LENGTH	UPC# 686334	MODEL	HIGH				LOW				VOLTS	PHASE	Wt. (lbs.)
			KW	BTU's	AMPS	CFM	KW	BTU's	AMPS	CFM			
33"	667142	6333D052033B30D0F	5	17065	25.0 / 17.6	250	3	10239	15.4 / 9.2	230	208	1-3*	99
	667159	6333D052433B30D0F			21.8 / 15.4				13.5 / 8.2		240	1-3*	
	667081	6333D054833B30D0F			7.8				4.6		480	3	
46"	667197	6346D102433B30D0F	10	34130	43.6 / 30.7	500	6	20478	26.9 / 16.2	460	240	1-3*	130
	667203	6346D104833B30D0F			15.4				8.1		480	3	
<b>International Models</b>													
33"	473620	6333D053834B30D0F1	5	17065	7.6	250	3	10239	4.56	230	380	3	99
	473637	6333D054134B30D0F1			6.97				4.18		415		
46"	473644	6346D103834B30D0F1	10	34130	15.2	500	6	20478	9.12	460	380	(4-Wire)	130
	473651	6346D104134B30D0F1			13.94				8.36		415		

\*Factory wired for 3-phase, field convertible to 1-phase.

- 1 / 3 phase field convertible with 24 Volt control circuit.
- Disconnect switch, dust filter, & high low operation.
- Built-in thermostat and field convertible for remote thermostat.

## Accessories

UPC# 686334	MODEL	SIZE	DESCRIPTION
<b>DUCT COLLAR</b>			
441568	DC-33	33"	The same model is used for the inlet or outlet. If duct collars are required for both inlet & outlet then 2 must be ordered.
441575	DC-46	46"	
441582	DC-66	66"	
441599	DC-79	79"	
<b>RECESSING TRIM FRAMES</b>			
453783	TF-33	33"	Recessing Trim Frames should be ordered to "trim-out" any recessed or semi-recessed installation.
453790	TF-46	46"	
453806	TF-66	66"	
453813	TF-79	79"	

UPC# 686334	MODEL	SIZE
<b>Fresh Air Make-Up Intake Flange &amp; Kickbase</b>		
771580	FAM33	33"
771597	FAM46	46"
771603	FAM66	66"
771610	FAM79	79"
<b>Kickbase (Pedestal) ONLY</b>		
771542	KB33	33"
771559	KB46	46"
771566	KB66	66"
771573	KB79	79"



# 6300 Series Multiple Angle Cabinet Unit Heater

## Custom Specified Models

### HOW TO DESIGNATE A MODEL:

<b>63</b>	<b>46</b>	<b>D</b>	<b>08</b>	<b>24</b>	<b>1</b>	<b>2</b>	<b>B3</b>	<b>S</b>	<b>D</b>	<b>O</b>	<b>F</b>
Series Number	Cabinet Size 33=33" 46=46" 66=66" 79=79"	Air Flow Configuration A = Bottom in / Top out B = Bottom in / Front out C = Front in / Top out D = Front in / Front out	Element KW 2KW through 24KW See model chart for length and KW options.	Element Voltage 20 = 208V 24 = 240V 27 = 277V 41 = 415V 48 = 480V 57 = 600V	Phase 1 = Single Phase 3 = Three Phase	Number of Wires in Electrical Service 2 or 3	Control Options B1, B2, B3, B4, B5, B6, B7, B8 (see control options chart)	Summer Fan Switch S = Included O = Not Included	Disconnect Option C = Circuit Breaker D = Disconnect Switch O = None	Motor Fusing Option M = Required O = Not Required	Disposable Filter Option F = Required O = Not Required
Step 1	Step 2	Step 3	Step 4	Step 5	Step 6	Step 7	Step 8	Step 9	Step 10	Step 11	Step 12

LENGTH	KW		Elements per Heat Deck		CFM		1-PHASE UNITS - AMPS (HIGH)				3-PHASE UNITS - AMPS (HIGH)			
	High	Low	Left	Right	High	Low	208V	240V	277V	600V	208V	240V	480V 3-WIRE	600V
33"	2	1	2		250	230	10.6	9.3	8.12	3.83	9.22	8.13	4.14	3.33
	3	2	3				15.4	13.5	11.7	5.5	9.22	8.13	4.14	3.38
	4	2	4				20.2	16.7	15.3	7.2	13.4	11.8	6	6.22
	5	3	5				25	21.8	19	8	17.6	15.4	7.8	5.5
	6	3	6				29.9	26	22.6	10.5	17.6	15.4	7.8	6.3
46"	4	2	2		500	460	21.1	18.6	16	7.46	18.7	16.2	8.1	6.5
	6	4	3				30.8	26.9	23.1	10.79	18.4	16.2	8.1	6.5
	8	4	4				40.4	35.2	30.5	14.12	26.7	23.4	11.7	9.4
	10	6	5				50	43.6	37.7	17.5	35.1	30.7	15.4	12.3
	12	6	6				59.6	51.9	44.9	20.8	35.1	30.7	15.4	12.3
66"	6	3	2	2	750	690	31.8	27.9	24.1	11.3	27.6	24.3	12.3	9.8
	9	6	3	3			46.2	40.4	35	16.3	27.6	24.3	12.3	9.9
	12	6	4	4			60.6	52.9	45.8	21.3	40.1	35.2	17.7	15.6
	15	9	5	5			75	65.4	56.7	25.5	52.6	46.1	23.1	15.7
	18	9	6	6			89.4	77.9	67.5	31.3	52.6	46.1	23.1	18.5
79"	8	4	2	2	1000	920	42.3	37.1	32	14.9	36.7	32.3	16.2	13
	12	8	3	3			61.5	53.8	46.5	21.6	36.7	32.3	16.2	13
	16	8	4	4			80.7	70.5	61	28.2	53.4	46.8	23.5	18.8
	20	12	5	5			NA	87.1	75.4	34.9	70.1	61.4	30.7	24.6
	24	12	6	6			NA	NA	89.8	41.6	70.1	61.4	30.7	24.6

Note: Amps include motor Amp loads.

# 6300 Series Multiple Angle Cabinet Unit Heater

## Control Option (Step 8 on Model Designator)

SUFFIX	DESCRIPTION
B3	In-Built 1-Stage Stat and Relays which are operated by an internal 24 Volt source.
B4*	In-Built 1-Stage Stat and Relays which are operated by an internal 120 Volt source.
B5	In-Built 2-Stage Stat & Relays which are operated by an internal 24 Volt source.
B6*	In-Built 2-Stage Stat and Relays which are operated by an internal 120 Volt source.

\*Motor fusing included for units with 120V internal or external control source.

## Disconnect Option "C" Circuit Breaker (Step 10 on Model Designator)

KW	SINGLE PHASE				THREE PHASE			
	208V	240V	277V	600V	208V	340V	480V	600V
2	available	available	available	available	available	available	available	available
3								
4								
5								
6								
8								
10								
12								
15	required	required	required	required	required	required	required	
16	N/A	N/A						
18								
20								
24						required		

Circuit breakers shown in shaded areas are required by NEC because unit exceeds 48 Amps, all others listed are optional unless otherwise stated.

## Disconnect Option "D" Disconnect Switch (Step 10 on Model Designator)

KW	SINGLE PHASE				THREE PHASE			
	208V	240V	277V	600V	208V	340V	480V	600V
2	available without circuit breaker option "C"	available without circuit breaker option "C"	available without circuit breaker option "C"	available without circuit breaker option "C"	available without circuit breaker option "C"	available without circuit breaker option "C"	available without circuit breaker option "C"	available without circuit breaker option "C"
3								
4								
5								
6								
8								
10								
12								
15	not available	not available	not available	available without circuit breaker option "C"	not available	available without circuit breaker option "C"	available without circuit breaker option "C"	
16	not available	not available	not available	available without circuit breaker option "C"	not available	available without circuit breaker option "C"	available without circuit breaker option "C"	available without circuit breaker option "C"
18								
20								
24								

Disconnect option is not available on heaters with circuit breaker.

## Fan Switch & Motor Fusing (Step 11 on Model Designator)

SUFFIX	DESCRIPTION
S	Summer Fan Switch
M	Motor Fusing (when not provided by control option)

## Filter Option (Step 12 on Model Designator)

SUFFIX	SIZE	Qty. REQ'D	FILTER TYPE
F	33"	1	Replaceable
	46"	1	
	66"	2	
	79"	2	
W	33"	1	Washable
	46"	1	
	66"	2	
	79"	2	

# 8500 Series Commercial Slope Top Wall Convector



Manufactured in U.S.A.

## HOW TO DESIGNATE A MODEL:

<b>85</b>	<b>2</b>	<b>5</b>	<b>125</b>	<b>H</b>	<b>B</b>	<b>DST1</b>
Series Number	Cabinet Size 3=20"H x 5"D 2=14"H x 5"D 1=10"H x 3"D	Unit Length (feet) 2, 3, 4, 5, 6, 7, 8, 9, 0 (enter 0 for 10')	Watts per Foot Selectable in 1 watt increments up to max per model series 8510=250 max 8520=500 max 8530=750 max	Voltage E=120V F=208V G=277V H=240V	Air Flow B=Bottom in F=Front in	Factory Installed Options blank=none T1 or T2=Thermostat R1, R2, or R9=Relay DS=Disconnect (see control option chart)
Step 1	Step 2	Step 3	Step 4	Step 5	Step 6	Step 7

- Front In/Top Out or Bottom In/Top Out air pattern.
- 16 gauge steel housing powder coated with beige finish.
- Tubular pre-wired wireway with 40 Amp capacity.
- Connection boxes for right or left hand wiring with combination 1/2" - 3/4" knockouts at back and bottom.
- Stainless steel element with Aluminum fins.
- Linear limit type thermal overload with automatic reset.
- Limited by max amp draw of 25 Amps (with no controls).

- Pencil proof louver design.
  - Custom colors available, consult factory.
- Note: Not for residential applications.  
Note: Disconnect limits amperage to 20 Amps.

## Standard Models

HEATER LENGTH	WATTS per FOOT	8510 SERIES		8520 SERIES		8530 SERIES	
		3" Depth x 10" Height Max watts per foot = 250		5" Depth x 14" Height Max watts per foot = 500		5" Depth x 20" Height Max watts per foot = 750	
		MODEL		MODEL		MODEL	
2'	100-250	8512		8522		8532	
	333-750						
3'	100-250	8513		8523		8533	
	333-750						
4'	100-250	8514		8524		8534	
	333-750						
5'	100-250	8515		8525		8535	
	333-750						
6'	100-250	8516		8526		8536	
	333-750						
7'	100-250	8517		8527		8537	
	333-750						
8'	100-250	8518		8528		8538	
	333-750						
9'	100-250	8519		8529		8539	
	333-750						
10'	100-250	8510		8520		8530	
	333-750						

Note: All models qualify for international use

Note: Products listed in this section are custom built and subject to 100% cancellation/restocking charges.

### CABINET:

Rugged 16 gauge front cover with discharge louvers in sloped top design. Pencil proof louver design for sloped outlet and front inlet grill. The finish shall be durable powder coated paint. Air flow available as bottom in - top out, or front in - top out.

### ELEMENT:

All steel high mass element construction with Nickel-Chromium resistance wire embedded in compacted efficient dielectric to ensure proper heat transfer. Aluminum fins mechanically bonded to steel tube allows for increased surface area and even heat transfer.

### LIMIT CONTROLS:

Automatic reset hydraulic thermal overload covers full length of heating element and shuts down heater when safe operating temperatures are exceeded.

### WIRING:

Connection boxes in either end with 1/2 inch to 3/4 inch knockouts at back and bottom. Tubular prewired wire way with 40 Amp capacity.

### CONTROLS:

Optional built in tamper resistant thermostat and disconnect is adjustable through top outlet louver.

### MOUNTING:

Heater shall be surface mounted to wall or mullion. Bottom inlet units must be mounted a minimum of 4 inches above finished floor front inlet.

### Voltage & Wattage Specification

Voltage	Standard Wattages Per Foot	Heater Lengths
120-277	100,125,150,165,187,200,250	2' through 10'

### In-Built Control Options

SUFFIX	DESCRIPTION
T1	In-Built Tamper Proof, Single Pole, Bimetal Thermostat - 0°-110°F temp. range, 25 Amp
T2	In-Built Tamper Proof, Double Pole, Bimetal Thermostat - 0°-110°F temp. range, 25 Amp
DS	Double Pole Disconnect Switch, 20 Amp

Note: Due to size limitations, 8510 series convectors can only have thermostats as In-Built control options.

SUFFIX	DESCRIPTION
R1	DPST Relay, 30 Amps, up to 277V, 120V coil
R2	SPST Relay, 18 Amps @ 277V (max), 24V coil
R9	24V Transformer and SPST Relay, 22 Amps @240V, 18 Amps @ 277V (max), 24V coil (cannot be used in conjunction with T2 option)

### Mounting/Air Flow Options

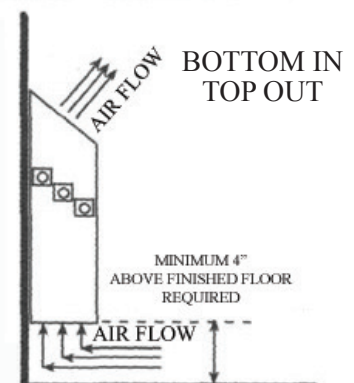
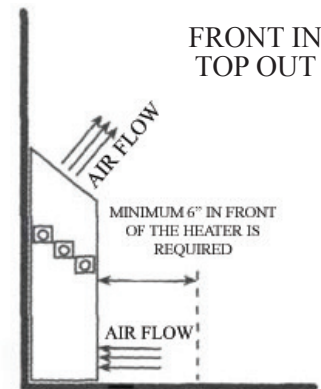



# 8800 Series Institutional Wall Convectors

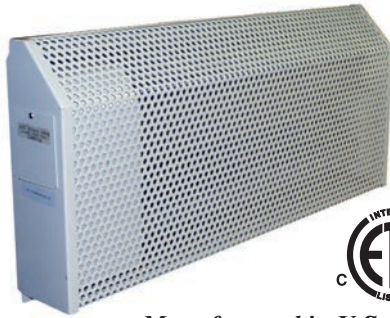

Manufactured in U.S.A.

- Single phase heaters available in all common voltages from 120V to 600V.
  - 11 gauge perforated steel housing powder coated with textured ivory finish.
  - Tamper proof left side control panel houses built-in single pole thermostat - range 40°F-110°F and disconnect switch. Thermostat on 120V-277V units is line voltage and low voltage (24V) on 346V-600V units.
  - Linear limit type thermal overload with automatic reset.
  - Tamper proof fasteners
  - Stainless steel element with Aluminum fins.
- Note: Not for residential applications.

## Standard Models

UPC#	MODEL	WATTS	BTU'S	VOLTS	AMPS	LENGTH (IN.)
686334						
899000	E8801050	500	1706	120	4.167	18
899062	F8801050			208	2.404	
899123	H8801050			240	2.083	
899185	G8801050			277	1.805	
899246	L8801050			346	1.445	
899307	P8801050			480	1.042	
899369	U8801050			600	0.833	
899017	E8802075	750	2560	120	6.25	28
899079	F8802075			208	3.606	
899130	H8802075			240	3.125	
899192	G8802075			277	2.708	
899253	L8802075			346	2.168	
899314	P8802075			480	1.563	
899376	U8802075	600	1.25			
899024	E8803100	1000	3413	120	8.333	36
899086	F8803100			208	4.808	
899147	H8803100			240	4.167	
899208	G8803100			277	3.610	
899260	L8803100			346	2.890	
899321	P8803100			480	2.083	
899383	U8803100	600	1.667			
899031	E8804125	1250	4266	120	10.417	48
899093	F8804125			208	6.010	
899154	H8804125			240	5.208	
899215	G8804125			277	4.513	
899277	L8804125			346	3.613	
899338	P8804125			480	2.604	
899390	U8804125	600	2.083			
899048	E8805150	1500	5120	120	12.5	60
899109	F8805150			208	7.212	
899161	H8805150			240	6.25	
899222	G8805150			277	5.415	
899284	L8805150			346	4.335	
899345	P8805150			480	3.125	
899406	U8805150	600	2.5			
899055	E8806200	2000	6826	120	16.667	72
899116	F8806200			208	9.615	
899178	H8806200			240	8.333	
899239	G8806200			277	7.220	
899291	L8806200			346	5.780	
899352	P8806200			480	4.167	
899413	U8806200	600	3.333			

## International Models

UPC#	MODEL	WATTS	BTU'S	VOLTS	AMPS	LENGTH (IN.)
686334						
984140	M8801050i	500	1706	220	2.3	18
984157	H8801050i			240	2.1	
984164	M8802075i	750	2560	220	3.4	28
984171	H8802075i			240	3.1	
984188	M8803100i	1000	3413	220	4.5	36
984195	H8803100i			240	4.2	
984201	M8804125i	1250	4266	220	5.7	48
984218	H8804125i			240	5.2	
984225	M8805150i	1500	5120	220	6.8	60
984232	H8805150i			240	6.3	
984249	M8806200i	2000	6826	220	9.1	72
984250	H8806200i			240	8.3	

### CABINET:

Institutional enclosure 11 gauge perforated steel with sloped top design. Heavy duty end caps welded to the enclosure. Control compartment for housing thermostat and disconnect switch is accessible by use of security type fastener. The entire enclosure is protected by epoxy powder coated paint finish.

### ELEMENT:

All steel high mass element construction with Nickel-Chromium resistance wire embedded in compacted efficient dielectric to ensure proper heat transfer. Aluminum fins mechanically bonded to steel tube allows for increased surface area and even heat transfer.

### LIMIT CONTROLS:

Automatic reset hydraulic thermal overload covers full length of heating element and shuts down heater when safe operating temperatures are exceeded.

### WIRING:

Wiring connections shall be made in left end of cabinet enclosure. Wiring must enter into control enclosure behind perforated steel grill.

### CONTROLS:

All controls are accessible only through control enclosure door. Security type fasteners restrict access to controls. Built in thermostat and disconnect switch with manual adjustment are located in control enclosure.

#### HOW TO DESIGNATE A MODEL:

H	880	3	100
Element Voltage E=120 F=208 G=277 H=240 L=346 P=480 U=600	Series Number	Unit Length 1=18" 2=28" 3=36" 4=48" 5=60" 6=72"	Unit Wattage 050=500 075=750 100=1000 125=1250 150=1500 200=2000

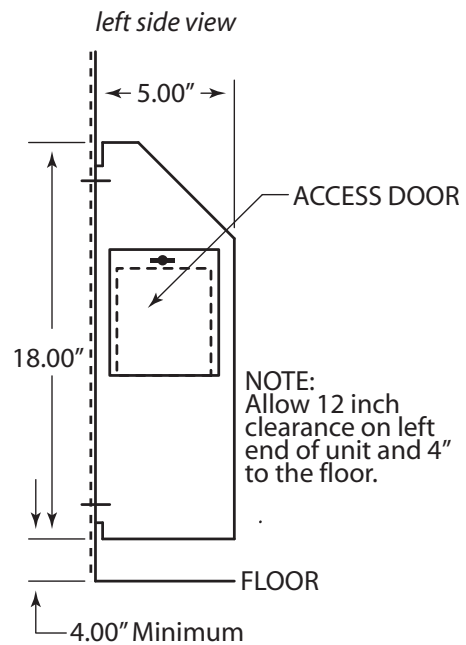

#### Optional In-Built Controls

SUFFIX	DESCRIPTION
T2	Tamperproof, Hydraulic, Double pole In-Built thermostat range 40°-110°F, 25 Amp
24V*	24 Volt In-Built single pole thermostat for 120V 208V, 240V & 277V models.

\*Not available on international models

# 4100 Series Recessed Commercial Wall Convectors

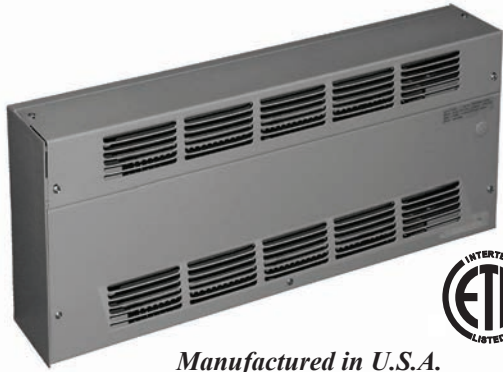

Manufactured in U.S.A.

- Front In / Front Out air pattern
- 16 gauge steel housing powder coated with textured beige finish.
- Tubular pre-wired wireway with 40 Amp capacity.
- Connection boxes for right or left hand wiring with combination 1/2"-3/4" knockouts at back and bottom.
- Steel heating element with steel fins.
- Linear limit thermal overload with automatic reset.

## HOW TO DESIGNATE A MODEL:

<b>M41</b>	<b>25</b>	<b>F</b>	<b>48</b>	<b>1000</b>	<b>T</b>
<u>Series Number</u>	<u>Cabinet Size</u> 45=20"H x 5"D 25=11"H x 4"D	<u>Voltage/Phase</u> G=277V, 1 Phase F=208V, 1 Phase J=208V, 3 Phase H=240V, 1 Phase K=240V, 3 Phase	<u>Unit Length (Inches)</u> 24, 36, 48, 60, or 72	<u>Total Wattage</u>	<u>Control Option</u> Blank=None R, R2, or R9=Relay T or T2=Thermostat (See control option chart)

- Recess trim frame included.
  - Custom colors available, consult factory.
- Note: Not for residential applications.

### M4125 Dimensions - Cabinet Sizes 4" Deep x 11" High

LENGTH (Inches)	WEIGHT (Lbs.)	WATTS per FOOT AVAILABLE	VOLTS AVAILABLE	PH
24	20	187 250 333	208 240 277	1
36	33			
48	39			
60	49			
72	56			

### M4145 Dimensions - Cabinet Sizes 5" Deep x 20" High

LENGTH (Inches)	WEIGHT (Lbs.)	WATTS per FOOT AVAILABLE	VOLTS AVAILABLE	PH	LENGTH (Inches)	WEIGHT (Lbs.)	WATTS per FOOT AVAILABLE	VOLTS AVAILABLE	PH
24	45	187 250 333	208 240 277	1	24	49	750	208 240 277	1
36	53				36	60			
48	63				48	71			
60	77				60	87			
72	92				72	106			
24	47	500 666	208 240 277	1	24	49	500 666 750	208 240	3
36	57				36	60			
48	67				48	71			
60	82				60	87			
72	100				72	106			

Note: Products listed in this section are custom built and subject to 100% cancellation/restocking charges.

**CABINET:**

4100 series casing shall be of square design with front inlet and outlet grills suitable for recess installation. The cabinet is fabricated from 16 gauge cold rolled steel and finished with powder coated baked enamel. Junction boxes are available for left or right wiring and connected by pre-wired 40 Amp capacity wireway.

**ELEMENT:**

All steel high mass element construction with Nickel-Chromium resistance wire embedded in compacted efficient dielectric to ensure proper heat transfer. Aluminum fins mechanically bonded to steel tube allows for increased surface area and even heat transfer.

**LIMIT CONTROLS:**

Automatic reset hydraulic thermal overload covers full length of heating element and shuts down heater when safe operating temperatures are exceeded.

**WIRING:**

Wiring connections shall be made in left end of cabinet enclosure. Wiring must enter into control enclosure behind perforated steel grill.

**CONTROLS:**

All controls are accessible only through control enclosure door. Security type fasteners restrict access to controls. Built in thermostat with manual adjustment are located in control enclosure.

*In-Built Control Options for Single Phase Units*

SUFFIX	DESCRIPTION
T	In-Built Tamper Proof, Single Pole, Hydraulic Thermostat - 40°-110°F temp. range, 25 Amps
T2	In-Built Tamper Proof, Double Pole, Hydraulic Thermostat - 40°-110°F temp. range, 25 Amps
R	DPST Relay, 30 Amps, up to 277V, 120V coil
R2	SPST Relay, 18 Amps @ 277V (max), 24V coil
R9	24V Transformer and SPST Relay, 22 Amps @24V, 18 Amps @ 277V (max), 24V coil

Note: No In-Built control options for 3 phase models.

*12" Control Section*

UNIT LENGTH	MODEL 4125	MODEL 4145
12"	MSE4120-12	MSE4140-12

Note: Control section required when relay is ordered.

*Solid Back Panel*

UNIT LENGTH	MODEL 4125	MODEL 4145
24"	MS4122	MS4142
36"	MS4123	MS4143
48"	MS4124	MS4144
60"	MS4125	MS4145
72"	MS4126	MS4146



# 3000 Series Fan Forced Ceiling Heater



Manufactured in U.S.A.



## Standard Models

WHITE		SELECTABLE INSTALLATION WATTAGE	MAX BTU'S	VOLTS	MAX AMPS
UPC#	MODEL				
686334					
948821	E3035DWBW	750 or 1500	5120	120	13
948838	E3038DWBW	900 or 1800	6143	120	15
948883	H3032DWBW	750 or 1000 - 1500 or 2000	6826	208 / 240	8
948906	G3032DWBW	2000	6826	277	7

## Field Installed Accessories

UPC	MODEL	DESCRIPTION
686334		
996846	30R	24 VOLT RELAY
996853	30R2	120 VOLT RELAY
951500	30R8	208/240 VOLT RELAY
951494	30R7	277 VOLT RELAY
996976	303EX8RW	1" EXTENDER
996969	303EX16RW	2" EXTENDER
996952	303EX32RW	4" SURFACE MOUNT FRAME
460033	TB3000	T-BAR FRAME

## Selectable Wattages, Back Cans, And Power Disconnects

- Wattage selectable at time of installation - models shipped wired to highest Wattage
- Fan purge circuit (has 2 wire control circuit for use with remote wall thermostat)
- Models may not be used with remote double pole thermostat
- Drywall depth embossments on back can
- Powder coated 18 gauge steel front
- Manual reset thermal limit
- Steel block fin element
- Propeller style fan blade - 1060 RPM / 100 CFM
- Weight 6 lbs.
- Optional field installed control voltage relays available
- Rough in dimensions - 9 1/4" Wide - 12 1/8" High - 3 5/8" Deep
- Grill dimensions: 9 25/32" Wide - 13" High

# 3380 Series Commercial Fan Forced Ceiling Heater

## Product Specifications

The heaters are be constructed of a heavy gauge steel housing. The rough-in dimensions are 19-3/16" wide x 4" deep. The finish shall be baked-on powder coat in Ceiling White color. The units shall be available in ratings from 1500 through 4800 Watts with an optional factory installed single pole thermostat.

The heaters have a low speed 600-RPM motor, which drives a vane axial blower to deliver a quite 175 CFM's of down flow air. The heating element shall be of the block finned type with large, parallel steel fins for quick heat transfer. Unit shall have as standard, a manual reset capillary type limit control, for added safety. Unit weight 22 pounds.



Manufactured in U.S.A.

## Features & Standard Models

### Recess, Surface, Or "T" Bar Mounting



- Fan purge circuit (has 2 wire control circuit for use with remote wall thermostat)
- Disconnect switch
- White powder coated 18 gauge steel grill
- Manual reset thermal limit
- Steel block fin element
- Vane axial fan blade:  
1.5KW - 4.0KW units: 700 RPM motor; 175 CFM  
4.8KW units: 900 RPM motor; 200 CFM
- Rough in dimensions:  
14 3/16" wide x 19 5/16" high x 4" deep
- Grill dimensions:  
15 3/8" wide x 20 9/64" high
- Optional factory installed tamper resistant thermostat

UPC#	MODEL	KW	BTU'S	VOLTS	PH	AMPS	TEMP RISE	
686334								
366489	E3383D-RP	1.5	5120	120	1	12.5	27 °F	
366298	F3386D-RP	4.0	13600	208		19.2	72 °F	
366304	F3387D-RP	4.8	16382	208		23.1	76 °F	
366342	HF3384D-RP	2.0 / 1.5	6826/5120	240/208		8.3/7.2	36 °F	
366359	HF3385D-RP	3.0 / 2.3	10200/7679	240/208		12.5/10.8	54 °F	
366366	HF3386D-RP	4.0 / 3.0	13600/10200	240/208		16.8/14.4	72 °F	
366373	H3387D-RP	4.8	16382	240		20	76 °F	
366502	G3383D-RP	1.5	5120	277		5.4	27 °F	
366410	G3384D-RP	2.0	6826	277		7.2	36 °F	
366427	G3385D-RP	3.0	10200	277		10.8	54 °F	
366434	G3386D-RP	4.0	13600	277		14.4	72 °F	
366441	G3387D-RP	4.8	16382	277		17.3	76 °F	
International Models								
470889	M3384D-RPi	1680	5734	220		1	7.6	30 °F
470896	M3385D-RPi	2520	8600		11.5		50 °F	
470902	M3386D-RPi	4032	13761		18.3		72 °F	

## Accessories

UPC	MODEL	DESCRIPTION	WT.
686334			
377850	BOX3310	Additional Back Can	10 lbs
381109	3380EX33	Surface Mounting Adapter	1 lb
460026	TB3380	2X2 T-Bar Mounting Kit	7 lbs
Thermostat- Add suffix T to model		Factory installed single pole, positive off. Range-60° F-105° F	

# 3480 Series Commercial Fan Forced Recessed Mounted Ceiling Heater

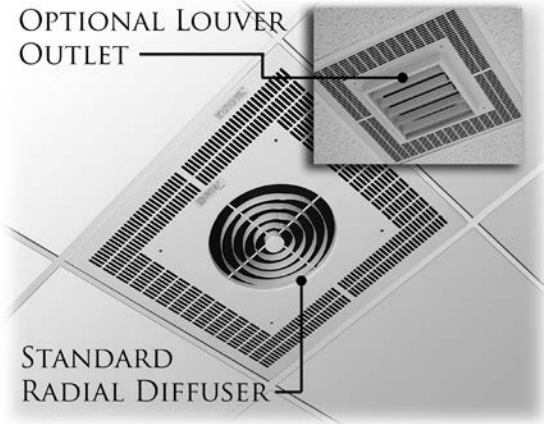

Manufactured in U.S.A.

### Notes

Optional controls must be factory installed. Field installation is not acceptable and violates Listing and factory warranty.

Wall mounted control panels may control multiple units but cannot be used if in-built controls are selected.

480V units include 24V transformer and relay as standard (A1) - only TS option control section can be added. Depth dimension of all 480V models is 10-7/8"

Degree F air rise is measured at 710 F.P.M. and 425 CFM. Throw designed for 8 to 12 foot ceilings. db RE 10<sup>-12</sup> Watt=63.9

Unit Weight: 50 lbs.

Recommended Remote Thermostats:

Line Voltage: Single Phase 208-240V ET5DS  
 Single Phase 277V ET5SS  
 Three Phase TW1512

Low Voltage: UT1001

### Product Specifications

Contractor shall supply and install heavy duty ceiling mounted forced air electric heater(s) of the wattage, voltage and phase as indicated on the plans. The heater shall be so designed to provide an even distribution of heated air to the space to be heated by drawing return air in the periphery of the heater, across and through the element and be discharged from the center section of the heater by means of an electric motor and axial flow fan blade.

Heaters shall be recessed type and mounted flush with the finished ceiling. The return grille assembly shall be constructed of a one piece heavy gauge steel with 1/4" slots for return air and concentric rings for uniform air discharge. Grille assembly shall be attached to chassis by tamper-resistant (allen head) machine screws. All parts of enclosure shall be heavy gauge steel, zinc coated both sides and finished in neutral off white powder coat paint.

Enclosure shall be constructed of 1/6" x 3/8" rounded edge horizontal steel louvers which shall be spaced for maximum opening of 5/16". Louvers shall be welded at every intersection to evenly spaced 1/8" diameter vertical members. Discharge grille to have concentric rings for uniform air discharge. Grille assembly shall be attached to chassis by tamper-resistant (allen head) machine screws. All part of enclosure shall be heavy gauge steel, Zinc coated both sides and finished in no more than 60 Watts per inch.

Motor shall be permanent lubricated, unit bearing, totally enclosed, impedance protection. Motors shall operate at no more than 1300 RPM and shall be same voltage as the heater.

Heaters shall have a rating of 425 CFM at 710 F.P.M. with a maximum temperature rise of 44°F and 63.9 DB RE 10<sup>12</sup> Watt.

Element assemblies shall consist of two or three corrosion resistant steel sheathed type elements mechanically bonded to common corrosion resistant steel fins. Each sheathed element shall consist of helically coiled Nickel Chromium alloy resistant wire completely embedded in and surrounded by magnesium oxide, enclosed and wedged into corrosion resistant steel sheaths. Elements shall have 2" cold conductor pins extending into sheath and shall have a density of no more than 60 Watts per inch.

Heaters shall be equipped with a "manual reset" thermal overload which disconnects elements and motor in the event normal operating temperatures are exceeded. For safety, if opened due to abnormal temperature, thermal overload shall remain open until manually reset. Automatic reset thermal overloads which allow the element to continue to cycle under abnormal conditions will not be accepted. Heaters shall be ETL listed.

### Features

- White powder coated 20 gauge grill.
- 208V, 240V, & 277V units have manual reset thermal limit.
- 480V units have manual reset thermal limit, 24V control transformer, and 24V relay (A1 suffix).
- Enclosed steel fin sheath element.
- Rough in dimensions: 23-1/16" sq. x 9-1/8" deep.



### Standard Models

UPC#	MODEL	KW	BTU'S	VOLTS	PH	AMPS	TEMP RISE
686344							
367653	F3482	2	6826	208	1	9.6	15 °F
367677	H3482			240		8.3	
367660	G3482			277		7.2	
318471	P3482A1			480		4.2	
470186	J3482	2	6826	208	3	5.6	15 °F
470209	K3482			240		4.8	
470247	Y3482A1			480		2.4	
367684	F3483			208		14.4	
367707	H3483	3	10200	240	1	12.5	22 °F
367691	G3483			277		10.8	
318488	P3483A1			480		6.3	
470193	J3483			208		8.3	
470216	K3483	3		240	3	7.2	
470254	Y3483A1			480		3.6	
367714	F3484			208		19.2	
367738	H3484			240		16.8	
367721	G3484	4	13600	277	1	14.4	30 °F
318501	P3484A1			480		8.3	
367745	J3484			208		11.1	
367752	K3484			240		9.7	
318587	Y3484A1	4		480	3	4.8	
367769	F3485			208		24.1	
367783	H3485			240		20.8	
367776	G3485			277		18.1	
318549	P3485A1	5	17000	480	1	10.4	37 °F
367790	J3485			208		13.9	
367806	K3485			240		12.1	
318402	Y3485A1			480		6.1	
366106	PT3480	Recess Frame - Weight 5 lbs.					

### International Models

470971	M3482T2i	2	6826	220	1	9.1	15 °F
470988	N3482T2i			240		8.3	
470995	M3483T2i			220		13.6	
471008	N3483T2i	3	10200	240	1	12.5	22 °F
471015	M3484T2i			220		18.2	
471022	N3484T2i	4	13600	240		16.7	30 °F

### Factory Installed Control Sections

SUFFIX	DESCRIPTION
A1	Transformer with 24V Secondary and 24V Relay
S	Disconnect Switch
TA1S	Thermostat / Transformer / Disconnect Switch
TA1	Single Pole Thermostat and Transformer with 24V Secondary and 24V Relay
A1S	Transformer with 24V Secondary and 24V Relay and Disconnect Switch
T2	Double Pole Thermostat
T2S	Double Pole Thermostat and Disconnect Switch
R	Relay Control Voltage Same as Heater (control voltage field supplied)
R1	Relay 24V Control Voltage (control voltage field supplied)
R2	Relay 120V Control Voltage (control voltage field supplied)
T	Single Pole (480V only)
L	Factory installed adjustable louver diffuser option.

### Product Dimensions

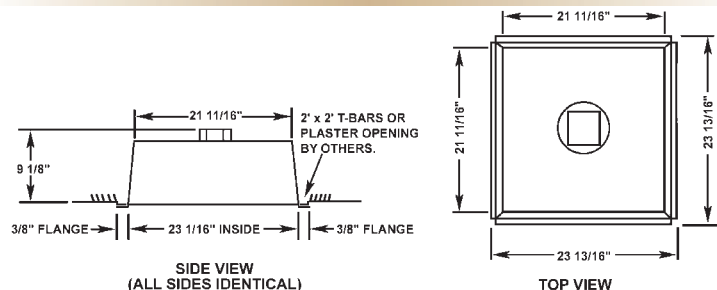

# 3470 Series Commercial Fan Forced Surface Mounted Ceiling Heater

## Product Specifications

Contractor shall supply and install heavy duty ceiling mounted forced air electric heater(s) of the wattage, voltage and phase as indicated on the plans. The heater shall so be designed to provide an even distribution of heated air to the space to be heated by drawing return air in the periphery of the heater, across and through the element and be discharged from the center section of the heater by mean of an electric motor and axial flow fan blade.

**Motor:** Motor shall be permanent lubricated, unit bearing, totally enclosed shaded pole type with impedance protection. Motors shall operate at no more than 1300 RPM and shall be same voltage as the heater.

**Performance:** Heaters shall have a rating of 425 CFM at 710 F.P.M. with a maximum temperature rise of 44°F and 63.9 DB RE 1012 Watt.

**Element:** Element assemblies shall consist of two or three corrosion resistant steel sheathed type elements mechanically bonded to common corrosion resistant steel fins. Each sheathed element shall consist of helically coiled Nickel Chromium alloy resistant wire completely embedded in and surrounded by Magnesium Oxide, enclosed and wedged into corrosion resistant steel sheaths. Elements shall have 2" cold conductor pins extending into sheath and shall have a density of no more than 60 watts per inch.

**Thermal Overload:** Heaters shall be equipped with a "manual reset" thermal overload which disconnects elements and motor in the event normal operating temperatures are exceeded. For safety, if opened due to abnormal temperature, thermal overload shall remain open until manually reset. Automatic reset thermal overloads which allow the element to continue to cycle under abnormal conditions will not be accepted.

**Approval:** Heaters shall be ETL listed.

**Commercial and Institutional Applications:** Use in - vestibules, entrance ways, lobbies, rest rooms and small office and guard building applications.



## Product Dimensions

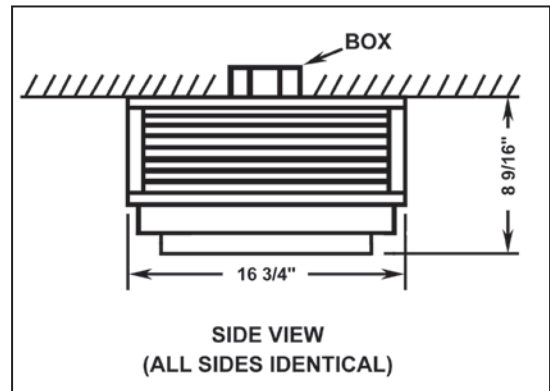

## Standard Models

UPC#	MODEL	KW	BTU'S	VOLTS	PH	AMPS	TEMP RISE	
686334								
367516	F3472	2	6826	208	1	9.6	15 °F	
367530	H3472			240		8.3		
367523	G3472			277		7.2		
324335	P3472A1	2	6826	480	3	4.2		
470155	J3472			208		5.6		
470162	K3472			240		4.8		
470223	Y3472A1	3	10200	480	1	2.4	22 °F	
367547	F3473			208		14.4		
367561	H3473			240		12.5		
367554	G3473	277	10.8					
324342	P3473A1	3	10200	480	3	6.3		22 °F
323864	J3473			208		8.3		
470179	K3473			240		7.2		
470230	Y3473A1	4	13600	480	1	3.6	30 °F	
367578	F3474			208		19.2		
367592	H3474			240		16.8		
367585	G3474	277	14.4					
324359	P3474A1	4	13600	480	3	8.3		30 °F
367608	J3474			208		11.1		
367837	K3474			240		9.7		
324366	Y3474A1	5	17000	480	1	4.8	37 °F	
367615	F3475			208		24.1		
367639	H3475			240		20.8		
367622	G3475	277	18.1					
324373	P3475A1	5	17000	480	3	10.4		37 °F
367646	J3475			208		13.9		
367844	K3475			240		12.1		
324380	Y3475A1	4	13600	480	1	6.1	30 °F	
470919	M3472T2i			220		9.1		
470926	N3472T2i			240		8.3		
470933	M3473T2i	3	10200	220	1	13.6		22 °F
470940	N3473T2i			240		12.5		
470957	M3474T2i	4	13600	220	1	18.2		30 °F
470964	N3474T2i			240		16.7		

### International Models

## Factory Installed Control Sections

SUFFIX	UNITS	DESCRIPTION
TS	1-Phase	Single Pole Thermostat - range 40°-110°F and Disconnect Switch
TA1S	3-Phase	Single Pole Thermostat - range 40°-110°F & Transformer with 24V Secondary and 24V Relay & Disconnect Switch
A1S	1 or 3 Phase	Transformer with 24V Secondary and 24V Relay and Disconnect Switch
T		Single Pole (480V only)

## Wall Mounted Control Panels

UPC#	MODEL	VOLTS	CONTACTORS	BOX SIZE
605700	AF3401-24	208	1 @ 35 AMPS	12" x 12" x 4 1/2"
605793	AH3401-24	240		
605854	AG3401-24	277	2 @ 35 AMPS	15" x 15" x 4 1/2"
605748	AF3402-24	208		
605786	AH3402-24	240	3 @ 35 AMPS	18" x 18" x 4 1/2"
605847	AG3402-24	277		
605731	AF3403-24	208	3 @ 35 AMPS	18" x 18" x 4 1/2"
605779	AH3403-24	240		
605830	AG3403-24	277		

## Notes

Optional controls must be factory installed. Field installation is not acceptable and violates Listing and factory warranty.

Factory installed control sections add 2-5/16" to the height of the unit.

Wall mounted control panels may control multiple units but cannot be used if In-Built controls are selected.

480V units include 24V transformer and relay as standard (A1) - only TS option control section can be added. Depth dimension of all 480V models is 10-7/8"

Degree F air rise is measured at 710 F.P.M. and 425 CFM. Throw designed for 8 to 12 foot ceilings. db RE 10<sup>-12</sup> Watt=63.9

Unit weight: 32 lbs.

Recommended Remote Thermostats:  
Line Voltage: Single Phase 208-240V  
Single Phase 277V  
Three Phase

ET5DS  
ET5SS  
TW1512

Low Voltage:

UT1001



# CP & RCP Series Radiant Ceiling Panel Heaters

## Product Description

For Surface Or Recessed Installation, Radiant Ceiling Panels radiate energy like the solar radiation which warms us, heats objects, not the air. With no moving parts, these heating panels create gentle warmth and toasty comfort.



*Manufactured in U.S.A.*

Radiant Ceiling Panels provide a low surface temperature and broad heat distribution. Clean, gentle comfortable heat that is ideal for offsetting perimeter heat loss or neutralizing downdrafts over glass. These versatile and flexible panels may be used virtually anywhere in homes, schools, hospitals, motels and a broad variety of other commercial or industrial installations.

## Product Specifications

### Construction:

Radiant Ceiling Panels shall be made of highest quality steel casing. Front panel shall be painted with textured powder coated finish. Electric Resistance element is fixed between dielectric material and insulation. Two inches of insulation is compressed to one inch by back panel to minimize upward heat loss and radiant efficiency. Radiant panels shall have 36" pre-wired flexible cable for easy installation and wiring connections.

### Installation:

CP Series shall be designated as 2x2 or 2x4 size. All panels are 1" thick. The size shall be nominal dimension to be manufactured to fit drop ceiling systems. Standard units will fit regular "T" Bar frame. For regular or trim line or other frame sizes, special construction is required. RCP Series shall be used in recess mounting applications. RCP Series shall be 2" less in width to recess between nominal 24" center ceiling joists. RCP Series shall be complete with recess frame for finished construction.

### Accessories:

Surface mounting frames shall be optional for surface mounting the CP Series, and are Aluminum mill finish. Frames can be painted white to match panel.

### Options:

Silk-screening the exposed surface to match ceiling tiles is available, as well as silicone sealed metal parts for high humidity applications.

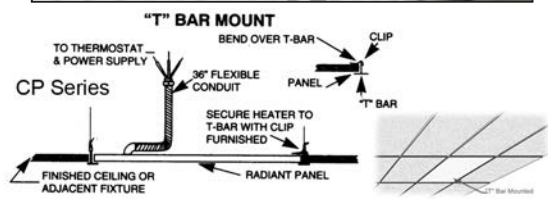

FOR SURFACE MOUNTED UNITS USE STANDARD "T" BAR CEILING PANEL AND SURFACE MOUNTING FRAME.

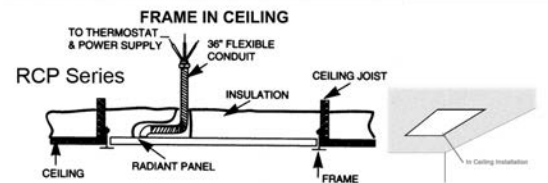
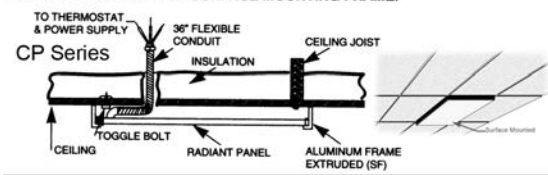

## CP Series - "T" Bar & Surface Mounted

UPC#	MODEL	WATTS	BTU's	AMPS	VOLTS	WT
686334	Dimensions: 2' x 4' (Nominal) x 1"					
458719	CP805	500	1707	2	208	20 lb.
458726	CP125			4.2/2.1	120/240	
458733	CP705			2	277	
458740	CP807	750	2560	4	208	20 lb.
458757	CP127			6.3/3.1	120/240	
458764	CP707			3	277	
Dimensions: 2' x 2' (Nominal) x 1"						
458771	CP802	250	853	1	208	13 lb.
458788	CP122			2.1/1.0	120/240	
458795	CP702			.9	277	
458801	CP803	375	1280	2	208	13 lb.
458818	CP123			3.1/1.6	120/240	
458825	CP703			1	277	
459105	SF400 Surface Frame for 2' x 4' Panels (CP only)					10 lb.
459099	SF200 Surface Frame for 2' x 2' Panels					6 lb.

## RCP Series - Frame in Ceiling Mounted

UPC#	MODEL	WATTS	BTU's	AMPS	VOLTS	WT
686334	Dimensions: 2' x 4' (Including Recessing Frame)					
458832	RCP805	500	1707	2	208	30 lb.
458849	RCP125			4.2/2.1	120/240	
458856	RCP705			2	277	
458863	RCP807	750	2560	4	208	30 lb.
458870	RCP127			6.3/3.1	120/240	
458887	RCP707			3	277	
Dimensions: 2' x 2' (Including Recessing Frame)						
458894	RCP802	250	853	1	208	19 lb.
458900	RCP122			2.1/1.0	120/240	
458917	RCP702			.9	277	
458924	RCP803	375	1280	2	208	19 lb.
458931	RCP123			3.1/1.6	120/240	
458948	RCP703			1	277	

## International Models

UPC#	MODEL	WATTS	BTU's	AMPS	VOLTS	WT
686334	Dimensions: 2' x 4' (Nominal) x 1"					
471039	CP2205i	420	1434	1.9	220	20
471046	CP125i	500	1707	4.2/4.1	120/240	
471053	CP2207i	630	2150	2.9	220	20
471060	CP127i	750	2560	6.3/3.1	120/240	
Dimensions: 2' x 2' (Nominal) x 1"						
471077	CP2202i	210	717	0.95		13
471084	CP122i	250	853	2.1/1.0	120/240	
471091	CP2203i	315	1075	1.4	220	13
471107	CP123i	375	1280	3.1/1.6	120/240	

UPC#	MODEL	WATTS	BTU's	AMPS	VOLTS	WT
686334	Dimensions: 2' x 4' (Including Recessing Frame)					
471114	RCP2205i	420	1434	1.9	220	30
471121	RCP125i	500	1707	4.2/4.1	120/240	
471138	RCP2207i	630	2150	2.9	220	
471145	RCP127i	750	2560	6.3/3.1	120/240	
Dimensions: 2' x 2' (Including Recessing Frame)						
471152	RCP2202i	210	717	0.95	220	19
471169	RCP122i	250	853	2.1/1.0	120/240	
471176	RCP2203i	315	1075	1.4	220	
471183	RCP123i	375	1280	3.1/1.6	120/240	



# CVX Series Radiant Cove Ceiling Heater

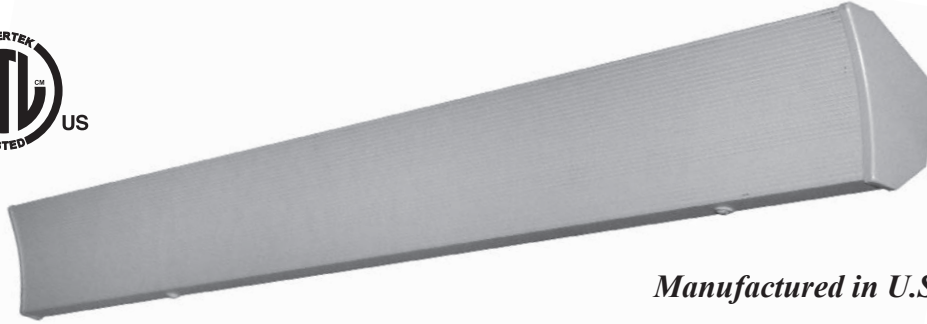

*Manufactured in U.S.A.*

## Product Description

Cove Heaters have a subtly contoured concave surface with a saw-tooth profile. The concave parabolic face plate performs a two-fold function: (1) it focuses the infrared rays and (2) directs the heat downward along cold perimeters and toward the center of the room. The sawtooth surface design increases the radiating surface area by 45%, thereby increasing the comfort level of the room faster and insuring more rapid recovery from heat losses.

## Product Specifications

Furnish and install Electric Cove Heaters where specified. The heaters shall be constructed of .962" thick Aluminum. The heater surface shall be concave in contour and saw-tooth in profile. The finish shall be of powder coat white finish. The heaters shall be available in ratings from 450 through 1250 Watts, at 120, 240, 208 and 277 Volts. The heating element shall be of Nichrome wire, embedded in Magnesium Oxide powder, enclosed and sealed in Aluminum metal tubing. The heater shall be listed by ETL and the elements shall be supplied with a one year limited warranty.

### Standard Models

UPC#	MODEL	WATTS	BTU's	AMPS	VOLTS	LENGTH	WT.
686334							
457583	CV4512X	450	1536	4	120	42"	7 lb.
457590	CV45X	450		2	240		
457606	CV45YX	450		2.0	208		
457613	CV4527X	450		2	277		
457620	CV6012X	600	2048	5.0	120	60"	10 lb.
457637	CV60X	600		3	240		
457644	CV60YX	600		3	208		
457651	CV6027X	600		2	277		
457668	CV7512X	750	2560	6	120	72"	13 lb.
457675	CV75X	750		3	240		
457682	CV75YX	750		3.6	208		
457699	CV7527X	750		3	277		
457705	CV9012X	900	3072	8	120	84"	14 lb.
457712	CV90X	900		4	240		
457729	CV90YX	900		4	208		
457736	CV9027X	900		3	277		
457743	CV10012X	1000	3413	8	120	96"	17 lb.
457750	CV100X	1000		4	240		
457767	CV100YX	1000		5	208		
457774	CV10027X	1000		4	277		
457781	CV11012X	1100	3754	9	120	108"	19 lb.
457798	CV110X	1100		5	240		
457804	CV110YX	1100		5	208		
457811	CV11027X	1100		4.0	277		
457828	CV12512X	1250	4266	10	120	120"	21 lb.
457835	CV125X	1250		5	240		
457842	CV125YX	1250		6.0	208		
457859	CV12527X	1250		5	277		
International Models							
471190	CV4522Xi	450	1536	2.0	220	42"	7
471206	CV45Xi			1.9	240		
471213	CV6022Xi	600	2048	2.7	220	60"	10
471220	CV60Xi			2.5	240		
471237	CV7522Xi	750	2560	3.4	220	72"	13
471244	CV75Xi			3.1	240		
471251	CV9022Xi	900	3072	4.1	220	84"	14
471268	CV90Xi			3.8	240		
471275	CV10022Xi	1000	3413	4.5	220	96"	17
471282	CV100Xi			4.2	240		
471299	CV11022Xi	1100	3754	5.0	220	108"	19
471305	CV110Xi			4.6	240		
471312	CV12522Xi	1250	4266	5.7	220	120"	21
471329	CV125Xi			5.2	240		

### Accessories & Dimensions

UPC#	MODEL	DESCRIPTION	WT.
686334			
457927	CVCBX	Ceiling Bracket*	1/2 lb.
457866	CVB42X	42" Blank Section	6 lb.
457873	CVB60X	60" Blank Section	8 lb.
457880	CVB84X	84" Blank Section	12 lb.
457912	CVSP	Aerosol Touch-up Paint	1 lb.

\* Order 2 for units up to 72"  
Order 3 for units over 72"

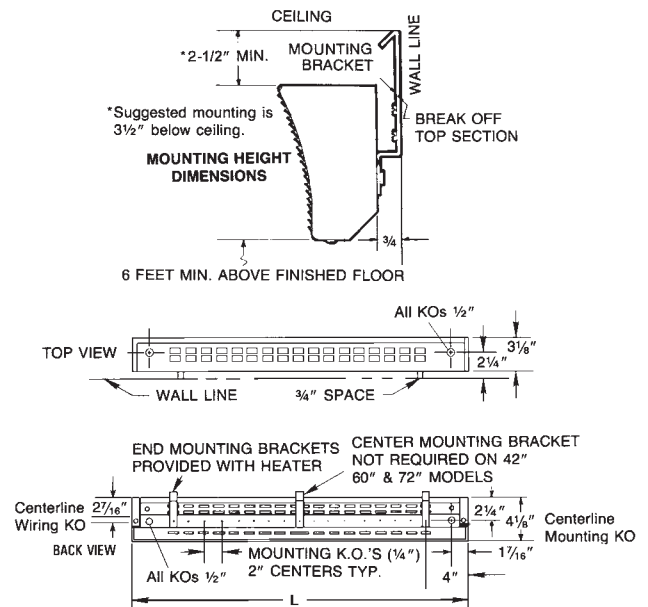



Approved for wall or ceiling installation

Manufactured in U.S.A.

### Features

- Wattage selectable at time of installation.
- Models shipped wired to highest wattage.
- Approved for horizontal mounting - right or left discharge.
- Fan purge circuit.
- Disconnect switch.
- Drywall depth embossments on back can.
- 18 gauge powder coated steel & extruded Aluminum front.
- Manual reset thermal limit.
- Steel block fin element.
- Propeller style fan blade: 1060 RPM motor; 100 CFM.
- Weight 6 lbs.
- Rough in dimensions: 9-1/4" Wide x 12-1/8" High x 3-5/8" Deep.
- Grill dimensions: 10" Wide x 13-1/8" High.

### Standard Models

UPC# 686334	MODEL	SELECTABLE INSTALLATION WATTAGE	MAX BTU's	VOLTS	MAX AMPS
<b>TAMPERPROOF IN-BUILT DOUBLE POLE THERMOSTAT (50° - 90° TEMPERATURE RANGE)</b>					
996211	E3055T2DWB	750 or 1500	5120	120	12.5
996228	E3058T2DWB	900 or 1800	6143	120	15.0
996259	F3052T2DWB	1000 or 2000	6826	208	8.3
945691	F30522T2DWB	500 or 750 or 1000 or 1250 or 1500 or 1750 or 2250	7680	208	10.8
996280	H3052T2DWB	750 or 1000 - 1500 or 2000	6826	208 / 240	8.3
945721	H30522T2DWB	500 or 750 or 1000 or 1250 or 1500 or 1750 or 2250	7680	240	9.4
996310	G3052T2DWB	2000	6826	277	7.2
<b>TAMPERPROOF IN-BUILT SINGLE POLE THERMOSTAT (50° - 90° TEMPERATURE RANGE)</b>					
996068	E3055TDWB	750 or 1500	5120	120	12.5
996075	E3058TDWB	900 or 1800	6143	120	15.0
996105	F3052TDWB	1000 or 2000	6826	208	8.3
945639	F30522TDWB	500 or 750 or 1000 or 1250 or 1500 or 1750 or 2250	7680	208	10.8
996136	H3052TDWB	750 or 1000 - 1500 or 2000	6826	208 / 240	8.3
945660	H30522TDWB	500 or 750 or 1000 or 1250 or 1500 or 1750 or 2250	7680	240	9.4
996167	G3052TDWB	2000	6826	277	7.2

### Accessories

UPC# 686334	MODEL	DESCRIPTION
996945	305EX8	1" EXTENDER
996938	305EX16	2" EXTENDER
996921	305EX32	4" SURFACE MOUNT FRAME

# 3320 Series Commercial Fan Forced Wall Heater



Manufactured in U.S.A.

### Features

- Disconnect switch.
- Automatic fan delay circuit.
- Powder coated 18 gauge steel grill with extruded Aluminum front frame.
- Automatic reset thermal limit.
- Steel block fin element.
- Vane axial fan blade:  
600 RPM motor; 175 CFM
- Rough-in dimensions:  
14-3/16" Wide x 19-7/16" High x 4" Deep
- Grill dimensions:  
15-29/32" Wide x 20-27/32" High
- Built-In tamper proof thermostat.



### Product Specifications

Furnish and install Heavy-Duty Forced Air wall heaters, where specified. The heaters shall be constructed of a heavy 18 gauge steel housing with an extruded Aluminum frame. The rough-in dimensions are 19-7/16" High x 14-3/16" Wide x 4" Deep. The units shall be available in ratings from 750 to 4800 Watts at 240, 208, and 277 Volts. The heaters shall have a low-speed 600 RPM, 4-pole motor which drives a vane axial blower to deliver a quiet 175 CFM of down flow air. The heating element shall be

of the sealed tubular type with large, parallel steel fins for quick heat transfer. Unit shall have as a standard, a thermal overload cut-off for added safety, fan delay switch and built-in tamper proof thermostat which shall be calibrated to provide a range of 55°F. to 85°F. and manual disconnect switch.

Optional accessories shall include a surface and semi-recess mounting adaptor. All heaters shall be listed by ETL. The heating element shall be supplied with a manufactures 1-year limited warranty.

### Standard Models

UPC#	MODEL	WATTS	BTU's	VOLTS	AMPS	WT. LBS.
IN-BUILT SINGLE POLE TAMPERPROOF THERMOSTAT (50° - 90° TEMPERATURE RANGE) FOR DOUBLE POLE THERMOSTAT REPLACE "T" IN MODEL NUMBER WITH "T2"						
382052	E3321TD-RP	750	2560	120	6.25	26
381994	E3322TD-RP	1000	3413		8.3	
380881	E3323TD-RP	1500	5120		12.5	
380935	F3326TD-RP	4000	13800	208	19.2	26
381024	F3327TD-RP	4800	16560		23	
380942	HF3323TD-RP	1500 / 1125	5120 / 3840	240 / 208	6.2 / 5.4	27
380959	HF3324TD-RP	2000 / 1500	6284 / 5120		8.3 / 7.2	
380966	HF3325TD-RP	3000 / 2250	10350 / 7763		12.5 / 10.8	
380973	HF3326TD-RP	4000 / 3000	13800 / 10350	240	16.7 / 14.4	29
381031	H3327TD-RP	4800	16560		20	
380980	G3323TD-RP	1500	5120	277	4.1	26
380997	G3324TD-RP	2000	6284		7.2	27
381000	G3325TD-RP	3000	10350		10.8	29
381017	G3326TD-RP	4000	13800	14.4		
381048	G3327TD-RP	4800	16560	17.3		
398077	J3326TD-RP	4000	13800	208	11.11	30
398084	J3327TD-RP	4800	16560		13.33	
398091	K3326TD-RP	4000	13800	240	9.64	30
398107	K3327TD-RP	4800	16560		11.57	
International Models						
396424	M3324TD-RPi	3360/1680	11468/5734	220	15.3/7.64	27
396437	M3325TD-RPi	4032/2016	13761/6881		18.3/9.16	

### Accessories

UPC	MODEL	DESCRIPTION	TYPE	WT. lbs.
686334				
377850	BOX 3310	Additional Rough-in Box	Field Installed	3
378451	3320EX33	4" Surface Mounting Frame		1
382939	3320EX16	2" semi recess extender		1
----	Suffix - HD	16 Gauge Steel Heavy Duty Grill	Factory Installed	2

## 4400 Series Low Profile Commercial Fan Forced Wall Heater - With Wall Box

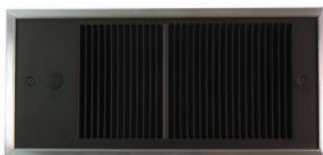

Manufactured in U.S.A.



- Powder coated 20 gauge steel front with extruded Aluminum frame.
- Manual reset thermal limit.
- Finned tubular steel element.

### Standard Models

UPC	MODEL	VOLTS	WATTS	MAX BTU'S	AMPS
686334					
DOUBLE POLE IN-BUILT THERMOSTAT (RANGE 50° - 90° F)					
328326	F4420T2RP	208	2000	6826	9.6
328333	HF4475T2RP	240/208	750 / 562	2560 / 1920	3.1 / 2.7
328340	HF4410T2RP		1000 / 750	3413 / 2560	4.2 / 3.6
328357	HF4415T2RP		1500 / 1125	5120 / 3840	6.3 / 5.4
328364	HF4420T2RP		2000 / 1500	6826 / 5120	8.3 / 7.2
SINGLE POLE IN-BUILT THERMOSTAT (RANGE 50° - 90° F)					
328371	E4475TRP	120	750	2560	6.25
328388	E4410TRP		1000	3413	8.33
328395	E4415TRP		1500	5120	12.5
328401	F4420TRP	208	2000	6826	9.6

### Accessories

UPC	MODEL	DESCRIPTION	WT. LBS.
686334			
329910	4400EX8	1" SEMI RECESSING EXTENDER	2
329903	4400EX16	2" SEMI RECESSING EXTENDER	3
329897	4400EX32	4" SURFACE MOUNTING FRAME	4
328449	4300PB	WALL PLATE ADAPTOR (OD 21.5"x12.25")	1

- Propeller style fan blade - 2200 RPM/70 CFM
- Weight 9 lbs.
- Rough in dimensions:  
14-1/2" Wide x 7-1/8" High x 3-1/2" Deep
- Grill dimensions: 16-7/8" Wide x 8" High
- Unit not approved for ceiling mount applications.
- Unit can be positioned to allow left, right or top discharge.

# 3420 & 3450 Series Heavy-Duty Fan Forced Wall Heaters



## Features

- Powder coated bar stock steel tamper proof grille, with extruded Aluminum frame and 16 gauge housing.
- In-Built double pole tamper proof thermostat with a 40°-110°F temperature range & positive off; 3 phase heaters have 3 pole thermostat for positive off position.
- Manual reset thermal limit switch.
- Corrosion resistant steel tubular element with brazed steel fins.
- Permanently lubricated, unit bearing, shaded pole motor with impedance protection.
- Propeller type fan blade:  
1400 RPM motor; 245 CFM
- Factory installed options:
  - contactors (3420 & 3450 series)
  - circuit breakers (3450 series)
  - control transformers (3450 series)

Note: Wall box required - may be ordered early for rough in purposes.



Manufactured in U.S.A.

## Standard Models

HEATER		WALL BOX		WATTS	BTU's	VOLTS	PH	AMPS	WT.
UPC 686334	MODEL	UPC 686334	MODEL						
<b>SERIES 3420 - ROUGH-IN DIMENSIONS: 19-3/8" H x 14-1/4" W x 4-1/4" D</b>									
<b>GRILL DIMENSIONS: 21-15/32" H x 17-7/16" W</b>									
691130	F3422T	691574	Box 3420	2000	6826	208	1	9.6	41 lbs.
691192	H3422T					240		8.3	
691178	G3422T					277		7.2	
384629	J3422T			2000	6826	208	3	5.6	
384634	K3422T					240		4.8	
691239	F3423T			3000	10239	208	1	14.4	
691314	H3423T					240		12.5	
691277	G3423T					277		10.8	
384636	J3423T			3000	10239	208	3	8.3	
384650	K3423T					240		7.3	
691338	F3424T			4000	13652	208	1	19.2	
691383	H3424T					240		16.7	
691369	G3424T					277		14.4	
691406	J3424T					208	3	11.1	
691413	K3424T					240		9.6	
691437	F3425T					208		24	
691512	H3425T			5000	17065	240	1	20.8	
691482	G3425T					277		18.1	
691536	J3425T	208	3			13.9			
691567	K3425T	240				12.0			

HEATER		WALL BOX		WATTS	BTU's	VOLTS	PH	AMPS	WT.
UPC 686334	MODEL	UPC 686334	MODEL						
<b>SERIES 3450 - ROUGH-IN DIMENSIONS: 23-1/16" H x 14-1/4" W x 4-1/4" D</b>									
<b>GRILL DIMENSIONS: 25-1/32" H x 17-7/16" W</b>									
691611	F3452T	691918	Box 3450	2000	6826	208	1	9.6	55 lbs.
691680	H3452T					240		8.3	
312295	G3452T					277		7.2	
384667	J3452T			2000	6826	208	3	5.6	
384681	K3452T					240		4.8	
687683	F3453T			3000	10239	208	1	14.4	
691772	H3453T					240		12.5	
312288	G3453T					277		10.8	
384674	J3453T			3000	10239	208	3	8.3	
384698	K3453T					240		7.3	
691789	F3454T			4000	13652	208	1	19.2	
691819	H3454T					240		16.7	
311991	G3454T					277		14.4	
691857	J3454T					208	3	11.1	
316651	K3454T					240		9.6	
312981	F3455T					208		10.4	
312134	H3455T			5000	17065	240	1	20.8	
312387	G3455T					277		18.1	
691901	J3455T	208	3			13.9			
313070	K3455T	240				12.0			



Contractor shall supply and install heavy duty wall mounted forced air electric heaters of the wattage, voltage and phase as specified. The heater shall so be designed to provide an even distribution of heated air to the space to be heated by drawing return air in the peripheral area of the heater across and through the element which shall then be discharged from the center section of the heater by means of an electric motor and axial flow fan blade. Heaters shall be recessed type to extend no more than 1-1/2" from the finished wall or surface mounted to extend no more than 5-3/4" from the finished wall or semi-recessed type to extend no more than 3-1/2" from finished wall or semi-recessed type to extend no more than 2-1/2" from finished wall.

### **ENCLOSURE:**

Heater front shall withstand 10.8 ft. lbs. (324 poundals) impact and 400 lbs. static force applied to an 8 sq. in. area at center grille location with less than 1/16" permanent distortion. The combination return and supply grille assembly shall be constructed of 1/16" x 3/8" rounded edge horizontal steel louvers which shall be spaced for maximum opening of 1/4". Louvers shall be welded at every intersection to three evenly spaced 1/16" diameter vertical members and completely framed in a heavy gauge natural anodized Aluminum extrusion. Front assembly shall be attached to the chassis by hidden tamper-resistant (Allen-head) machine screws. All other parts shall be 16 gauge steel Zinc coated, both sides finished in a high gloss or bronze colored baked powder coat finish.

### **MOTOR:**

Motor shall be a permanently lubricated unit bearing, totally enclosed shaded pole type with impedance protection. Motors shall operate at no more than 1400 RPM and shall be same voltage as the heater. A protective shield shall surround the motor to separate return air from heated air.

### **PERFORMANCE:**

Heaters shall have a rating of 245 CFM at 660 F.P.M. with a maximum temperature rise of 73°F.

### **ELEMENTS:**

Element assemblies shall consist of two or three corrosion resistant steel sheathed type elements mechanically bonded to common corrosion resistant steel fins. Each sheathed element shall consist of helically coiled Nickel Chromium alloy resistant wire completely embedded in and surrounded by Magnesium Oxide, enclosed and wedged into corrosion resistant steel sheaths. Elements shall have 2" cold conductor pins extending into the sheath and shall have a density of no more than 60 Watts per inch.

### **THERMAL OVERLOAD:**

Heaters shall be equipped with a "manual reset" thermal overload which disconnects elements and motor in the event normal operating temperatures are exceeded. For safety, if opened due to abnormal temperature, thermal overload shall remain open until manually reset. Automatic reset thermal overloads which allow the element to continue to cycle under abnormal conditions will not be accepted.

### **APPROVAL:**

Heaters shall be ETL Listed.

### **OPTIONAL CONTROL SYSTEMS:**

Heaters shall be operated from wall-mounted, line voltage, heavy-duty (tamper-proof) thermostats. Heaters with built-in, pre-wired contactors shall be operated from wall-mounted, line voltage, pilot duty (tamper-proof) thermostats. Heaters built with, pre-wired contactors (and control transformers) shall be operated from wall-mounted, pilot duty (24V) or (120V) wall-mounted tamper-proof thermostats. Heaters shall be controlled by integrally mounted thermostats. Thermostats shall be heavy-duty, hydraulic type with a range of 40°F to 80°F and with remote sensing bulb placed in the return air. Thermostats shall be electrically rated at least 125% of heater rating. Thermostats

## Product Specifications

shall be heavy-duty, hydraulic type with a range of 40°F to 80°F and with remote sensing bulb placed in the return air. Thermostats shall be electrically rated at least 125% of heater rating. Thermostats shall also act as a disconnect by breaking all ungrounded conductors in the OFF position. (Thermostat control knob shall be covered by a 16 gauge tamper-proof access plate to prevent adjustment by unauthorized personnel.)

### CONTACTORS:

Where required, heaters shall be equipped with heavy-duty, definite purpose contactors with flame path separators and dust covers. Contactors shall cycle all ungrounded conductors. Contactors shall have holding coils (of the same voltage as the heater) or (120 Volts) or (24 Volts).

### CONTROL TRANSFORMERS:

Heater shall be equipped with a Class 2 control transformer, sealed rating of 20 VA, to supply control circuits of (24 Volts) or (120 Volts). (120 Volt secondaries not available in single phase heaters over 3 KW).

### CIRCUIT BREAKERS (3450 Series Only):

Heaters shall be equipped with built-in circuit breakers in order to allow the heaters to be supplied from feeder taps. A separate switch providing a positive off for control circuits shall be included where required. Circuit breakers and control switches shall be arranged so that all line side conductors will be separately enclosed when heater front is removed for servicing so that no current carrying parts are accessible without the use of additional tools.

## Field Installed Accessories

Units with transformers must have a contactor. A control transformer with 120V secondary is available on all 3-phase models, 208V/240V 1-phase units up to 3KW, and up to 4 KW on 277V. All heaters must be installed with a wall box.

MODEL	DESCRIPTION	SERIES OPTIONS	
		3420	3450
Suffix - R	Contactor with Coil same as heater	YES	YES
Suffix - R1	Contactor with 24V Coil	YES	YES
Suffix - R2	Contactor with 120V Coil	YES	YES
Suffix - C	Circuit Breakers - all models	NO	YES
Suffix - A1	Control Transformers With 24V Secondary	NO	YES
Suffix - A2	Control Transformers With 120V Secondary	NO	YES

UPC# 686334	MODEL	DESCRIPTION	WT.
691949	3450EX34	4" Surface Mounting Sleeve	6 lb.
691932	3450EX16	2" Semi-Recessing Sleeve	4 lb.
691925	3450EX8	1" Semi-Recessing Sleeve	4 lb.
691604	3420EX34	4" Surface Mounting Sleeve	5 lb.
691598	3420EX16	2" Semi-Recessing Sleeve	4 lb.
691581	3420EX8	1" Semi-Recessing Sleeve	3 lb.

# 3310 Series Fan Forced Wall Heater - Without Summer Fan Switch



## Features

- Powder coated 18 gauge steel front.
- Automatic reset thermal limit.
- Vane axial fan blade: 600 RPM / 175 CFM.
- Rough in dimensions: 14-3/16" Wide x 19-15/16" High x 4" Deep.
- Grill dimensions: 15-3/8" Wide x 20-9/64" High.
- Steel block fin element.
- Weight 22 lbs.
- Units with dual wattage, factory wired to highest wattage.
- Wattage selectable at time of installation on some models.



Manufactured in U.S.A.



## Standard Models

MODELS WITH IN-BUILT DOUBLE POLE THERMOSTAT (50° - 90° F TEMPERATURE RANGE)							
IVORY		WHITE		WATTS	MAX BTU's	VOLTS	AMPS
UPC 686334	IVORY MODEL	UPC 686334	WHITE MODEL				
326346	E3312T2RP	326483	E3312T2RPW	1000	3413	120	8.3
326353	E3313T2RP	326490	E3313T2RPW	1500	5120		12.5
				750	2560		6.25
326360	F3316T2RP	326506	F3316T2RPW	4000	13648	208	19.2
326377	F3317T2RP	326513	F3317T2RPW	4800	16380		23
326407	HF3315T2RP	326544	HF3315T2RPW	3000 / 2250	10240	240 / 208	12.5 / 10.8
				1500 / 1125	5120		6.2 / 5.4
326414	HF3316T2RP	326551	HF3316T2RPW	4000 / 3000	13648		16.8 / 14.4
				2000 / 1500	6826		8.3 / 7.2
326421	H3317T2RP	326568	H3317T2RPW	4800	16380	240	20.0
326438	G3314T2RP	326575	G3314T2RPW	2000	6826	277	7.2
326445	G3315T2RP	326582	G3315T2RPW	3000	10240		10.8
326452	G3316T2RP	326599	G3316T2RPW	4000	13648		14.4
326469	G3317T2RP	326605	G3317T2RPW	4800	16380		17.3

MODELS WITH IN-BUILT SINGLE POLE THERMOSTAT (50° - 90° F TEMPERATURE RANGE)							
382526	E3312TRP	382618	E3312TRPW	1000	3413	120	8.3
380652	E3313TRP	384162	E3313TRPW	1500	5120		12.5
				750	2560		6.25
379946	F3316TRP	384186	F3316TRPW	4000	13648	208	19.2
380300	F3317TRP	384193	F3317TRPW	4800	16380		23
380560	HF3315TRP	382229	HF3315TRPW	3000 / 2250	10240	240 / 208	12.5 / 10.8
				1500 / 1125	5120		6.2 / 5.4
379984	HF3316TRP	382236	HF3316TRPW	4000 / 3000	13648		16.8 / 14.4
				2000 / 1500	6826		8.3 / 7.2
380317	H3317TRP	382243	H3317TRPW	4800	16380	240	20.0
329873	G3314TRP	384261	G3314TRPW	2000	6826	277	7.2
328494	G3315TRP	328517	G3315TRPW	3000	10240		10.8
328500	G3316TRP	328524	G3316TRPW	4000	13648		14.4
379179	G3317TRP	384292	G3317TRPW	4800	16380		17.3

MODELS WITHOUT AN IN-BUILT THERMOSTAT							
326629	E3312RP	326766	E3312RPW	1000	3413	120	8.3
326636	E3313RP	326773	E3313RPW	1500	5120		12.5
				750	2560		6.25
328531	F3316RP	326780	F3316RPW	4000	13648	208	19.2
326650	F3317RP	326797	F3317RPW	4800	16380		23
326681	HF3315RP	326827	HF3315RPW	3000 / 2250	10240	240 / 208	12.5 / 10.8
				1500 / 1125	5120		6.2 / 5.4
326698	HF3316RP	326834	HF3316RPW	4000 / 3000	13648		16.8 / 14.4
				2000 / 1500	6826		8.3 / 7.2
326704	H3317RP	326841	H3317RPW	4800	16380	240	20.0
326711	G3314RP	326858	G3314RPW	2000	6826	277	7.2
326728	G3315RP	326865	G3315RPW	3000	10240		10.8
326735	G3316RP	326872	G3316RPW	4000	13648		14.4
326742	G3317RP	326889	G3317RPW	4800	16380		17.3

# 3310 Series Fan Forced Wall Heater - With Summer Fan Switch



## Features

- Powder coated 18 gauge steel front.
- Automatic reset thermal limit.
- Steel block fin element.
- Weight 22 lbs.
- Vane axial fan blade: 600 RPM / 175 CFM.
- Grill dimensions: 15-3/8" Wide x 20-9/64" High.
- Rough in dimensions: 14-3/16" Wide x 19-15/16" High x 4" Deep.
- Units with dual wattage, factory wired to highest wattage.
- Wattage selectable at time of installation on some models.



Manufactured in U.S.A.



## Product Specifications

Typical Specifications: Furnish and install Electric Forced Air Heaters where specified. The heaters shall be constructed of a heavy gauge steel housing. The rough-in dimensions are 14-3/16" Wide x 19-5/16" High x 4" Deep. The finish shall be powder coated paint in ivory or white color. The units shall be available in ratings from 750 through 4800 Watts. The heaters shall have a low speed 600 RPM motor which drives a vane axial blower to deliver a quiet 175 CFM of down flow air. The heating element shall be of the sealed block fin type with large, parallel steel fins for quick heat transfer. Unit shall have a standard thermal overload cutoff for added safety, a fan switch for fan only operation, and is available with a single pole, or double pole built-in thermostat, or no thermostat. The in-built thermostat shall be calibrated to provide a range of 50 degrees F. to 90 degrees F. All heaters shall be listed by ETL. The heating element shall be supplied with a manufacturer's 1 year limited warranty.

## Standard Models

MODELS WITH IN-BUILT DOUBLE POLE THERMOSTAT (50° - 90°F TEMPERATURE RANGE)							
IVORY		WHITE		WATTS	MAX BTU's	VOLTS	AMPS
UPC 686334	IVORY	UPC 686334	WHITE				
326063	E3312T2SRP	326209	E3312T2SRPW	1000	3413	120	8.3
326070	E3313T2SRP	326216	E3313T2SRPW	1500	5120		12.5
				750	2560		6.25
326087	F3316T2SRP	326223	F3316T2SRPW	4000	13648	208	19.2
326094	F3317T2SRP	326230	F3317T2SRPW	4800	16380		23
326124	HF3315T2SRP	326261	HF3315T2SRPW	3000 / 2250	10240	240 / 208	12.5 / 10.8
				1500 / 1125	5120		6.2 / 5.4
326131	HF3316T2SRP	326278	HF3316T2SRPW	4000 / 3000	13648		16.8 / 14.4
				2000 / 1500	6826	8.3 / 7.2	
326148	H3317T2SRP	326285	H3317T2SRPW	4800	16380	240	20.0

MODELS WITH IN-BUILT SINGLE POLE THERMOSTAT (50° - 90°F TEMPERATURE RANGE)							
382571	E3312TSRP	382595	E3312TSRPW	1000	3413	120	8.3
379618	E3313TSRP	384018	E3313TSRPW	1500	5120		12.5
				750	2560		6.25
377713	F3316TSRP	384025	F3316TSRPW	4000	13648	208	19.2
377782	F3317TSRP	384032	F3317TSRPW	4800	16380		23
377607	HF3315TSRP	384070	HF3315TSRPW	3000 / 2250	10240	240 / 208	12.5 / 10.8
				1500 / 1125	5120		6.2 / 5.4
377690	HF3316TSRP	384087	HF3316TSRPW	4000 / 3000	13648		16.8 / 14.4
				2000 / 1500	6826	8.3 / 7.2	
377768	H3317TSRP	384094	H3317TSRPW	4800	16380	240	20.0
International Models							
----	----	396480	M3315T2SRPW	3360	11468	220	15.27
				1680	5734		7.64
----	----	396493	M3316T2SRPW	4032	13761		18.33
				2016	6881	9.16	

Note: Fan switch not available on 277V models. 277V models are available without a fan switch on previous page.

## Accessories - All Models

IVORY		WHITE		DESCRIPTION	ACCESSORY TYPE
UPC 686334	MODEL	UPC 686334	MODEL		
377850	BOX3310	377850	BOX3310	ADDITIONAL BACK CAN	Field Installed
329958	3310EX33R	329965	3310EX33WR	SURFACE MOUNTING FRAME	
SUFFIX D				DISCONNECT SWITCH	Factory Installed



# 3200 Series Midsized Fan Forced Wall Heater - With Wall Box



SHOWN WITH BUILT-IN THERMOSTAT

## Features

- Units have white powder coat finish.
- Approved for horizontal mounting - right or left discharge.
- Drywall depth embossments on back can.
- Powder coated 18 gauge steel front.
- Manual reset thermal limit.
- Finned tubular steel element.
- Weight 6 lbs.
- Propeller style fan blade: 2200 RPM / 70 CFM.
- Optional field installed In-Built thermostat.
- Rough in dimensions: 9-1/4" Wide, 12-1/8" High, 3-5/8" Deep.
- Grill dimensions: 9-25/32" Wide, 13" High.



Manufactured in U.S.A.

## "TWO WIRE INSTALLATION"

## Standard Models

UPC 686334	MODEL	VOLTS	WATTS	MAX BTU'S	AMPS
<b>BUILT-IN DOUBLE POLE (POSITIVE OFF) THERMOSTAT 50° - 90° F RANGE</b>					
383462	F3220T2RPW	208	2000	6826	9.6
383479	H3275T2RPW	240	750	2560	3.1
383486	HF3210T2RPW	240/208	1000 / 750	3413 / 2560	4.2 / 3.6
383493	HF3215T2RPW		1500 / 1125	5120 / 3840	6.3 / 5.4
383509	HF3220T2RPW		2000 / 1500	6826 / 5120	8.3 / 7.2
383516	HF3222T2RPW		2250 / 1688	7680 / 5762	9.4 / 8.1
<b>International Models - BUILT-IN DOUBLE POLE (POSITIVE OFF) THERMOSTAT 50° - 90° F RANGE</b>					
396387	M3210T2RPWi	220	840	2867	3.8
396394	M3215T2RPWi		1260	4300	5.7
396400	M3220T2RPWi		1680	5734	7.6
396417	M3222T2RPWi		1890	6451	8.6
<b>Standard Models - BUILT-IN SINGLE POLE (POSITIVE OFF) THERMOSTAT 50° - 90° F RANGE</b>					
383523	E3275TRPW	120	750	2560	6.25
383530	E3210TRPW		1000	3413	8.33
383547	E3215TRPW		1500	5120	12.5
<b>NO BUILT-IN THERMOSTAT</b>					
383554	E3275RPW	120	750	2560	6.25
383561	E3210RPW		1000	3413	8.33
383578	E3215RPW		1500	5120	12.5
383585	F3220RPW	208	2000	6826	9.6
383592	H3275RPW	240	750	2560	3.1
383608	HF3210RPW	240/208	1000 / 750	3413 / 2560	4.2 / 3.6
383615	HF3215RPW		1500 / 1125	5120 / 3840	6.3 / 5.4
383622	HF3220RPW		2000 / 1500	6826 / 5120	8.3 / 7.2
383639	HF3222RPW		2250 / 1688	7680 / 5762	9.4 / 8.1

## Accessories

FIELD INSTALLED COMPONENTS		
UPC 686334	MODEL	DESCRIPTION
383646	32T1	Single Pole thermostat with positive off for 120V units 50° - 90° F
383653	32T2	Double Pole thermostat with positive off for 240/208V units 50° - 90° F

SURFACE MOUNTED EXTENDERS & FRAMES		
WHITE		DESCRIPTION
UPC 686334	MODEL	
996976	303EX8RW	1" EXTENDER
996969	303EX16RW	2" EXTENDER
996952	303EX32RW	4" SURFACE MOUNT FRAME

# 4300 Series Low Profile Fan Forced Wall Heater - With Wall Box

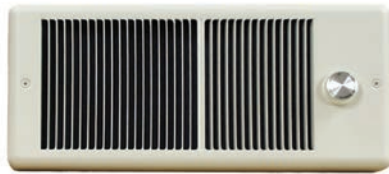

WITH IN-BUILT THERMOSTAT

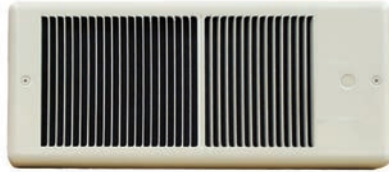

WITHOUT IN-BUILT THERMOSTAT

## Features

- Available in ivory or white.
- Powder coated 20 gauge steel front.
- Manual reset thermal limit.
- Finned tubular steel element.
- Weight 9 lbs.
- Propeller style fan blade - 2200 RPM / 70 CFM
- Rough in dimensions: 14-1/2" Wide, 7-1/8" High, 3-1/2" Deep
- Grill dimensions: 16-3/4" Wide, 7-5/8" High
- Unit not approved for ceiling mount applications.
- Unit can be positioned to allow left, right or top discharge.



Manufactured in U.S.A.

## Standard Models

IVORY		WHITE		VOLTS	WATTS	MAX BTU's	AMPS
UPC 686334	MODEL	UPC 686334	MODEL				
<b>DOUBLE POLE IN-BUILT THERMOSTAT (RANGE 50° - 90°F)</b>							
327695	F4320T2RP	327749	F4320T2RPW	208	2000	6826	9.6
327701	HF4375T2RP	327756	HF4375T2RPW	240/208	750 / 562	2560 / 1920	3.1 / 2.7
327718	HF4310T2RP	327763	HF4310T2RPW		1000 / 750	3413 / 2560	4.2 / 3.6
327725	HF4315T2RP	327770	HF4315T2RPW		1500 / 1125	5120 / 3840	6.3 / 5.4
327732	HF4320T2RP	327787	HF4320T2RPW		2000 / 1500	6826 / 5120	8.3 / 7.2
<b>International Models - DOUBLE POLE IN-BUILT THERMOSTAT (RANGE 50° - 90°F)</b>							
----	----	396448	M4375T2RPi	220	630	2150	2.9
----	----	396455	M4310T2RPi		840	2869	3.8
----	----	396462	M4315T2RPi		1260	4300	5.7
----	----	396479	M4320T2RPi		1680	5733	7.6
<b>Standard Models - SINGLE POLE INBUILT THERMOSTAT (RANGE 50° - 90°F)</b>							
327794	E4375TRP	327879	E4375TRPW	120	750	2560	6.25
327800	E4310TRP	327886	E4310TRPW		1000	3413	8.33
327817	E4315TRP	327893	E4315TRPW		1500	5120	12.5
327824	F4320TRP	327909	F4320TRPW	208	2000	6826	9.6
327831	HF4375TRP	327916	HF4375TRPW	240/208	750 / 562	2560 / 1920	3.1 / 2.7
327848	HF4310TRP	327923	HF4310TRPW		1000 / 750	3413 / 2560	4.2 / 3.6
327855	HF4315TRP	327930	HF4315TRPW		1500 / 1125	5120 / 3840	6.3 / 5.4
327862	HF4320TRP	327947	HF4320TRPW		2000 / 1500	6826 / 5120	8.3 / 7.2
<b>NO IN-BUILT THERMOSTAT</b>							
327954	E4375RP	328036	E4375RPW	120	750	2560	6.25
327961	E4310RP	328043	E4310RPW		1000	3413	8.33
327978	E4315RP	328050	E4315RPW		1500	5120	12.5
327985	F4320RP	328067	F4320RPW	208	2000	6826	9.6
327992	HF4375RP	328074	HF4375RPW	240/208	750 / 562	2560 / 1920	3.1 / 2.7
328005	HF4310RP	328081	HF4310RPW		1000 / 750	3413 / 2560	4.2 / 3.6
328012	HF4315RP	328098	HF4315RPW		1500 / 1125	5120 / 3840	6.3 / 5.4
328029	HF4320RP	328104	HF4320RPW		2000 / 1500	6826 / 5120	8.3 / 7.2

## Accessories

UPC 686334	IVORY MODEL	UPC 686334	WHITE MODEL	ACCESSORY OPTIONS	WT. LBS.
327657	4300EX8	328456	4300EX8W	1" SEMI RECESSING EXTENDER	2
327664	4300EX16	328463	4300EX16W	2" SEMI RECESSING EXTENDER	3
327671	4300EX32	328470	4300EX32W	4" SURFACE MOUNTING FRAME	4
327688	4300P	328487	4300PW	WALL PLATE ADAPTOR (OD 21.5" x 12.25")	1
FIELD INSTALLED THERMOSTATS		329774	43T	SINGLE POLE THERMOSTAT 50° - 90° F	1
		329781	43T2	DOUBLE POLE THERMOSTAT 50° - 90° F	1

# 4800 Series Register Style Fan Forced Wall Heater - With Wall Box

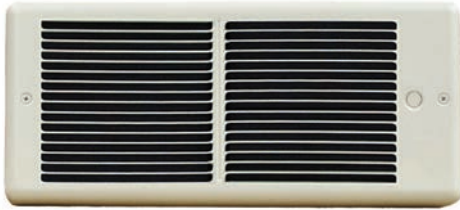

Manufactured in U.S.A.

## Features

- Units have white powder coat finish.
- Powder coated 20 gauge steel front.
- Manual reset thermal limit.
- Finned tubular steel element.
- Propeller style fan blade - 2200 RPM / 70 CFM.
- Weight 9 lbs.
- Rough in dimensions: 14-1/2" Wide x 7-1/8" High x 3-1/2" Deep.
- Grill dimensions: 16-3/4" Wide x 7-5/8" High.
- Unit not approved for ceiling mount applications.
- Left discharge only.

## Standard Models

UPC 686334	MODEL	VOLTS	WATTS	MAX BTU'S	AMPS
<b>DOUBLE POLE IN-BUILT THERMOSTAT (40° - 110° F TEMPERATURE RANGE)</b>					
328159	F4820T2RPW	208	2000	6826	9.6
328166	HF4875T2RPW	240/208	750 / 562	2560 / 1920	3.1 / 2.7
328173	HF4810T2RPW		1000 / 750	3413 / 2560	4.2 / 3.6
328180	HF4815T2RPW		1500 / 1125	5120 / 3840	6.3 / 5.4
328197	HF4820T2RPW		2000 / 1500	6826 / 5120	8.3 / 7.2
<b>SINGLE POLE IN-BUILT THERMOSTAT (50° - 90° F TEMPERATURE RANGE)</b>					
328203	E4875TRPW	120	750	2560	6.25
328210	E4810TRPW		1000	3413	8.33
328227	E4815TRPW		1500	5120	12.5
328234	F4820TRPW	208	2000	6826	9.6
<b>NO IN-BUILT THERMOSTAT</b>					
328241	E4875RPW	120	750	2560	6.25
328258	E4810RPW		1000	3413	8.33
328265	E4815RPW		1500	5120	12.5
328272	F4820RPW	208	2000	6826	9.6
328289	HF4875RPW	240/208	750 / 562	2560 / 1920	3.1 / 2.7
328296	HF4810RPW		1000 / 750	3413 / 2560	4.2 / 3.6
328302	HF4815RPW		1500 / 1125	5120 / 3840	6.3 / 5.4
328319	HF4820RPW		2000 / 1500	6826 / 5120	8.3 / 7.2

## Accessories

UPC# 686334	MODEL	DESCRIPTION	WT. LBS.
328456	4300EX8W	1" SEMI RECESSING EXTENDER	2
328463	4300EX16W	2" SEMI RECESSING EXTENDER	3
328470	4300EX32W	4" SURFACE MOUNTING FRAME	4
328487	4300PW	WALL PLATE ADAPTOR (OD 21.5" x 12.25")	1
329774	43T	SINGLE POLE THERMOSTAT 50° - 90° F	1
329798	48T2	DOUBLE POLE THERMOSTAT 50° - 90° F	1

# 3900 Series Hydronic Electric Baseboard Heater

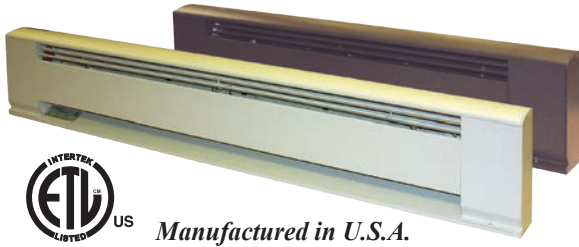

Manufactured in U.S.A.

- Permanent mount self contained unit.
- Heating elements are immersed in a heat transferring liquid enclosed by a Copper tube casing with Aluminum fins.
- Powder coated 12 gauge heavy duty extruded Aluminum housing with junction boxes located on each end of the unit.
- Automatic linear limit.
- Wire guard extends along the entire outlet area of the baseboard.
- Commercial Brown unit has in-built wireway.
- Special colors available, consult factory.
- Suitable for high altitude applications.
- 1 Year element warranty.

## Standard Models

STANDARD WHITE		COMMERCIAL BROWN		WATTS	BTU's.	VOLTS	AMPS	HEATER LENGTH (IN.)	WT. (LBS)
UPC 686334	MODEL	UPC 686334	MODEL						
111416	E3904-28	111645	E3904-28C	400	1360	120	3.3	28	16
111423	F3904-28	111652	F3904-28C	400	1360	208	1.92		
111430	H3904-28	111669	H3904-28C	400/300	1360/1024	240/208	1.6/1.4		
111447	G3904-28	111676	G3904-28C	400/300	1360	277/240	1.4		
111454	E3906-36	111683	E3906-36C	600	2048	120	5	36	22
111461	F3906-36	111690	F3906-36C	600	2048	208	2.9		
111478	H3906-36	111706	H3906-36C	600/450	2048/1536	240/208	2.5/2.2		
111485	G3906-36	111713	G3906-36C	600/450	2048	277/240	2.2		
111492	E3910-48	111720	E3910-48C	1000	3413	120	8.3	48	27
111508	F3910-48	111737	F3910-48C	1000	3413	208	4.8		
111515	H3910-48	111744	H3910-48C	1000/750	3413/2560	240/208	4.2/3.6		
111522	G3910-48	111751	G3910-48C	1000/750	3413	277/240	3.6		
111539	E3912-60	111768	E3912-60C	1250	4265	120	10.4	60	33
111546	F3912-60	111775	F3912-60C	1250	4265	208	6		
111553	H3912-60	111782	H3912-60C	1250/938	4265/3201	240/208	5.2/4.5		
111560	G3912-60	111799	G3912-60C	1250/938	4265	277/240	3.6		
111577	E3915-72	111805	E3915-72C	1500	5100	120	12.5	72	41
111584	F3915-72	111812	F3915-72C	1500	5100	208	7.2		
111591	H3915-72	111829	H3915-72C	1500/1125	5100/3825	240/208	6.3/5.4		
111607	G3915-72	111836	G3915-72C	1500/1125	5100	277/240	5.4		
111614	F3920-96	111842	F3920-96C	2000	6826	208	9.6	96	58
111621	H3920-96	111850	H3920-96C	2000/1500	6826/5100	240/208	8.3/7.2		
111638	G3920-96	111867	G3920-96C	2000/1500	6826	277/240	7.2		

## Product Specifications & Dimensions

The entire heater casing shall be constructed of 6063 extruded Aluminum. minimum thickness of .100" (12 gauge) Aluminum shall be acceptable. Outlet grill shall cover entire length of air discharge opening and be constructed of steel. All casing and grill construction shall be painted with high quality durable powder coated paint.

The heating element shall be high quality Nichrome wire encased in Magnesium Oxide and sealed in copper tube. The heating element shall be sealed in .312" diameter Copper tube and be immersed in heat transfer liquid. Aluminum fins shall be mechanically bonded to the entire heated length of the element for even heat transfer.

Linear automatic thermal limit shall extend the entire heater length of element and protect heater in case of an over-temperature condition.

Optional controls shall be mounted in junction box enclosures at either end of heater. Optional integral thermostat shall be located in junction box with adjustment knob or for tamper-proof operation. Optional disconnect switch shall be mounted in junction box. Optional 120 Volt or air conditioning receptacle shall be mounted in junction box.

Optional installation accessories shall include inside and outside corner sections for complete wall perimeter fit. Profile of corners and grill shall have appearance of heat sections for continuous architectural design. Corner accessories and heater sections shall be secured by alignment pins for easy alignment of multiple heater applications.

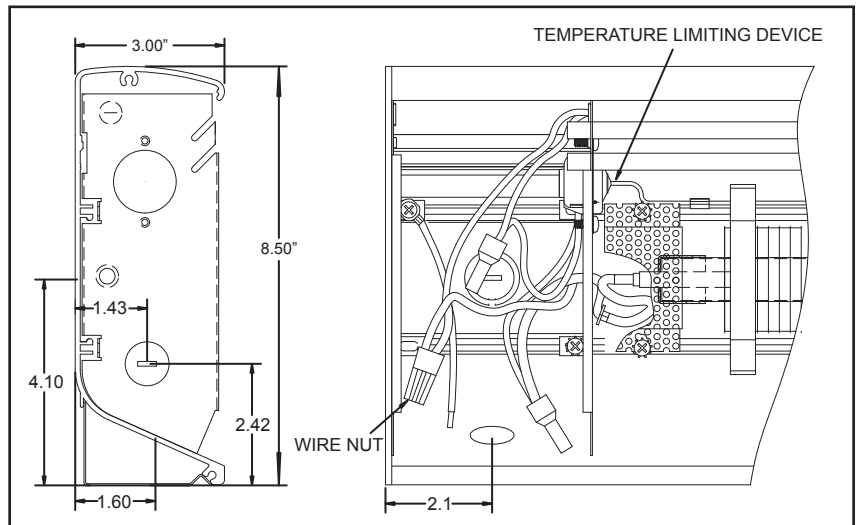



# 3700 Series Architectural Style Electric Baseboard Heater

- Available in white or brown with stainless steel heating element and aluminum fins.
- Powder coated 12 gauge heavy duty extruded Aluminum housing construction with junction boxes located on each end of the unit.
- An automatic thermal linear limit is used along the entire heated length of the unit.
- Wire guard extends along the entire outlet area of the baseboard.
- Special colors available, consult factory.

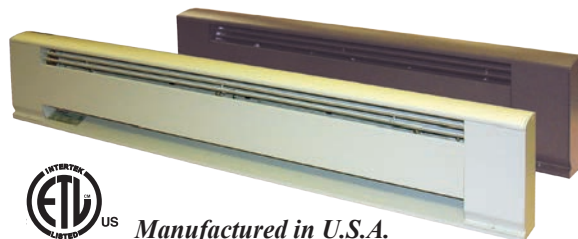

## Standard Models

## Product Specifications

STANDARD WHITE		COMMERCIAL BROWN		WATTS	BTU's	VOLTS	AMPS	HEATER LENGTH (IN.)	WT. (LBS.)
UPC 686334	MODEL	UPC 686334	MODEL						
116008	E3703-024	116435	E3703-024B	375	1275	120	3.1	24	14
116015	F3703-024	116442	F3703-024B	375	1275	208	1.8		
116022	H3703-024	116459	H3703-024B	375 / 281	1275 / 955	240 / 208	1.6/1.4		
116039	G3703-024	116466	G3703-024B	375 / 281	1275 / 955	277 / 240	1.6/1.2		
116046	E3705-028	116473	E3705-028B	500	1706	120	4.2	28	16
116053	F3705-028	116480	F3705-028B	500	1706	208	2.4		
116060	H3705-028	116497	H3705-028B	500 / 375	1706 / 1275	240 / 208	2.1/1.8		
116077	G3705-028	116503	G3705-028B	500 / 375	1706 / 1275	277 / 240	1.8/1.6		
116084	E3706-036	116510	E3706-036B	600	2040	120	5	36	22
116091	F3706-036	116527	F3706-036B	600	2040	208	2.9		
116107	H3706-036	116534	H3706-036B	600 / 450	2040 / 1530	240 / 208	2.5/2.2		
116114	G3706-036	116541	G3706-036B	600 / 450	2040 / 1530	277 / 240	2.2/1.9		
116121	E3707-040	116558	E3707-040B	750	2550	120	6.3	40	27
116138	F3707-040	116565	F3707-040B	750	2550	208	3.6		
116145	H3707-040	116572	H3707-040B	750 / 563	2550 / 1914	240 / 208	3.1/2.7		
116152	G3707-040	116589	G3707-040B	750 / 563	2550 / 1914	277 / 240	2.7/2.6		
116169	E3710-048	116596	E3710-048B	1000	3413	120	8.3	48	31
116176	F3710-048	116602	F3710-048B	1000	3413	208	4.8		
116183	H3710-048	116619	H3710-048B	1000 / 750	3413 / 2550	240 / 208	4.2/3.6		
116190	G3710-048	116626	G3710-048B	1000 / 750	3413 / 2550	277 / 240	3.6/3.1		
116206	G3707-048	116633	G3707-048B	750	2550	277	3.4		
116213	E3712-060	116640	E3712-060B	1250	4250	120	10.4	60	33
116220	F3712-060	116657	F3712-060B	1250	4250	208	6		
116237	H3712-060	116664	H3712-060B	1250 / 938	4250 / 3189	240 / 208	5.2/4.5		
116244	G3712-060	116671	G3712-060B	1250 / 938	4250 / 3189	277 / 240	4.5/3.9		
116251	G3709-060	116688	G3709-060B	938	3189	277	3.4		
116268	E3715-072	116695	E3715-072B	1500	5100	120	12.5	72	41
116275	F3715-072	116701	F3715-072B	1500	5100	208	7.2		
116282	H3715-072	116718	H3715-072B	1500 / 1125	5100 / 3825	240 / 208	6.3/4.7		
116299	G3715-072	116725	G3715-072B	1500 / 1125	5100 / 3825	277 / 240	5.4/4.7		
116305	G3711-072	116732	G3711-072B	1125	3825	277	4.1		
116312	F3717-084	116749	F3717-084B	1750	5950	208	8.4	84	49
116329	H3717-084	116756	H3717-084B	1750 / 1313	5950 / 4464	240 / 208	7.3/6.3		
116336	G3717-084	116763	G3717-084B	1750 / 1313	5950 / 4464	277 / 240	6.3/5.5		
116343	G3713-084	116770	G3713-084B	1313	4464	277	4.7		
116350	F3720-096	116787	F3720-096B	2000	6826	208	9.6	96	58
116367	H3720-096	116794	H3720-096B	2000 / 1500	6826 / 5100	240 / 208	8.3/7.2		
116374	G3720-096	116800	G3720-096B	2000 / 1500	6826 / 5100	277 / 240	7.2/6.3		
116381	G3715-096	116817	G3715-096B	1500	5100	277	5.4		
116398	F3725-120	116824	F3725-120B	2500	8532	208	12	120	67
116404	H3725-120	116831	H3725-120B	2500 / 1875	8532 / 6375	240 / 208	10.4/9.0		
116411	G3725-120	116848	G3725-120B	2500 / 1875	8532 / 6375	277 / 240	9.0/7.8		
116428	G3718-120	116855	G3718-120B	1875	6375	277	6.8		

The entire heater casing shall be constructed of 6063 extruded Aluminum. Minimum thickness of .100" (12 gauge) Aluminum shall be acceptable. Outlet grill shall cover entire length of air discharge opening and be constructed of steel. All casing and grill construction shall be painted with high quality durable powder coated paint.

The heating element shall be high quality nichrome wire encased in Magnesium Oxide and sealed in a stainless steel tube.

Linear automatic thermal limit shall extend the entire heater length of element and protect heater in case of an over-temperature condition.

Optional controls shall be mounted in junction box enclosures at either end of heater. Optional integral thermostat shall be located in junction box with adjustment knob or for tamper-proof operation. Optional disconnect switch shall be mounted in junction box. Optional 120 Volt or air conditioning receptacle shall be mounted in junction box.

Optional installation accessories shall include inside and outside corner sections for complete wall perimeter fit. Profile of corners and grill shall have appearance of heat sections for continuous architectural design. Corner accessories and heater sections shall be secured by alignment pins for easy alignment of multiple heater applications.

Note: Refer to 3900 Series for product dimension specifications.

## Field Installed Accessories

DESCRIPTION	Standard White		Commercial Brown	
	UPC# 686334	MODEL	UPC# 686334	MODEL
Single Pole, In-Built T-Stat, 22A @ 120-240V; 18A @ 277V; 50°-90° F	111874	3900T1	111959	3900T1C
Double Pole, In-Built T-Stat, 22A @ 120-240V; 18A @ 277V; 50°-90° F	111881	3900T2	111966	3900T2C
Air Conditioning Receptacle Section, 20 Amp @ 125-277V	111898	3900AC	111997	3900ACC
120V. Receptacle Section, 15 Amp	111904	3900REC	112000	3900RECC
Disconnect Switch, 20 Amp @ 125-277VAC; DPST	111942	3900DS	112048	3900DSC

## Baseboard Sections



OUTSIDE CORNER



INSIDE CORNER

Outside and inside corner sections are 6" on longest side

STANDARD WHITE		COMMERCIAL BROWN		DESCRIPTION	
UPC# 686334	MODEL	UPC# 686334	MODEL	SECTION	SIZE
112154	39BS28	112215	39BS28C	Blank Section	28"
112161	39BS36	112222	39BS36C		36"
112178	39BS48	112239	39BS48C		48"
112185	39BS60	112246	39BS60C		60"
112192	39BS72	112253	39BS72C		72"
112208	39BS96	112260	39BS96C		96"
115094	39BS120	115100	39BS120C		120"
111911	3900-ICS	112017	3900-ICSC	Inside Corner	-
111928	3900-OCS	112024	3900-OCSC	Outside Corner	-
111935	3900-CS	112031	3900-CSC	Control Section	4" Blank

## Dimension

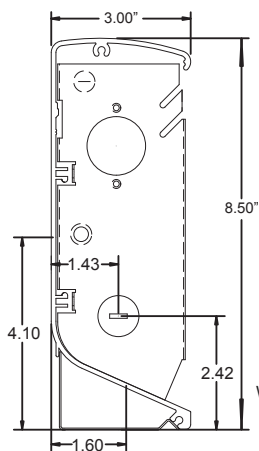

TEMPERATURE LIMITING DEVICE

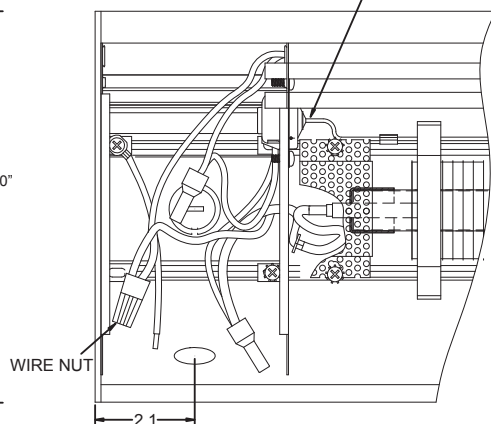

## Wireway Covers (White Units Only)

UPC# 686334	MODEL	LENGTH	SHIP WT. (LBS)
112284	3900WW28	28"	2
112291	3900WW36	36"	2.5
112307	3900WW48	48"	3.5
112314	3900WW60	60"	4.5
112321	3900WW72	72"	5.5
112338	3900WW96	96"	7.5
115117	3900WW120	120"	7.5

# 2900HA Series Electric Baseboard - High Altitude Convection Heater

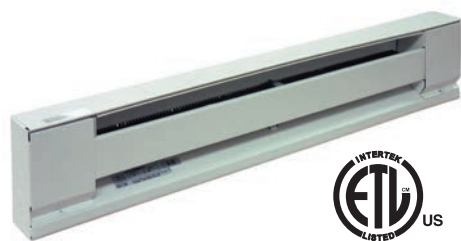

Manufactured in U.S.A.

## Features

- Available in white or ivory with Aluminum heating element and Aluminum fins.
- Painted 22 gauge steel front with 20 gauge junction boxes located on each end of the heater - junction boxes contain quick connect cable clamps and 6" ground lead wires.
- Over-temperature thermal limit extends entire length of heated area.
- A full length wireway provided along the back of the heater.
- Optional enclosed conduit wireway available.
- Heater can be mounted to the wall by using the key hole knockouts every 4" at the back of the heater.
- Optional In-Built thermostats field installed in the junction box.
- HEIGHT: 6" DEPTH: 2-1/2"
- Ivory available with extended lead times-consult factory.

## Standard Models

UPC# 686334	WHITE MODEL	WATTS	BTU's	VOLTS	AMPS	HEATER LENGTH (IN)	WT. (LBS.)
101226	E2903-024HAW	375	1275	120	3.1	24	5
101233	F2903-024HAW	375	1275	208	1.8		
101240	H2903-024HAW	375 / 281	1275 / 955	240 / 208	1.6/1.4		
101257	G2903-024HAW	375 / 281	1275 / 955	277 / 240	1.6/1.2		
101264	E2905-028HAW	500	1706	120	4.2	28	6
101271	F2905-028HAW	500	1706	208	2.4		
101288	H2905-028HAW	500 / 375	1706 / 1275	240 / 208	2.1/1.8		
101295	G2905-028HAW	500 / 375	1706 / 1275	277 / 240	1.8/1.6		
101301	E2906-036HAW	600	2040	120	5	36	7
101318	F2906-036HAW	600	2040	208	2.9		
101325	H2906-036HAW	600 / 450	2040 / 1530	240 / 208	2.5/2.2		
101332	G2906-036HAW	600 / 450	2040 / 1530	277 / 240	2.2/1.9		
101349	E2907-040HAW	750	2550	120	6.3	40	8
101356	F2907-040HAW	750	2550	208	3.6		
101363	H2907-040HAW	750 / 563	2550 / 1914	240 / 208	3.1/2.7		
101370	G2907-040HAW	750 / 563	2550 / 1914	277 / 240	2.7.2.6		
101387	E2910-048HAW	1000	3413	120	8.3	48	10
101394	F2910-048HAW	1000	3413	208	4.8		
101400	H2910-048HAW	1000 / 750	3413 / 2550	240 / 208	4.2/3.6		
101417	G2910-048HAW	1000 / 750	3413 / 2550	277 / 240	3.6/3.1		
101424	G2907-048HAW	750	2550	277	3.4	60	12
101431	E2912-060HAW	1250	4250	120	10.4		
101448	F2912-060HAW	1250	4250	208	6		
101455	H2912-060HAW	1250 / 938	4250 / 3189	240 / 208	5.2/4.5		
101462	G2912-060HAW	1250 / 938	4250 / 3189	277 / 240	4.5/3.9	72	14
101479	G2909-060HAW	938	3189	277	3.4		
101486	E2915-072HAW	1500	5100	120	12.5		
101493	F2915-072HAW	1500	5100	208	7.2		
101509	H2915-072HAW	1500 / 1125	5100 / 3825	240 / 208	6.3/4.7	96	18
101516	G2915-072HAW	1500 / 1125	5100 / 3825	277 / 240	5.4/4.7		
101523	G2911-072HAW	1125	3825	277	4.1		
101578	F2920-096HAW	2000	6826	208	9.6		
101585	H2920-096HAW	2000 / 1500	6826 / 5100	240 / 208	8.3/7.2	120	22
101592	G2920-096HAW	2000 / 1500	6826 / 5100	277 / 240	7.2/6.3		
101608	G2915-096HAW	1500	5100	277	5.4		
101653	F2925-120HAW	2500	8532	208	12		
101660	H2925-120HAW	2500 / 1875	8532 / 6375	240 / 208	10.4/9.0	120	22
101677	G2925-120HAW	2500 / 1875	8532 / 6375	277 / 240	9.0/7.8		
101684	G2918-120HAW	1875	6375	277	6.8		

## 2900A Series - International Models

UPC# 686334	WHITE MODEL	WATTS	BTU's	VOLTS	HEATER LENGTH (IN)	WEIGHT (LBS)
115766	M2903-24AWi	375	1275	220	24"	10
115773	H2903-24AWi			240		
115780	M2905-28AWi	500	1706	220	28"	11
115977	H2905-28AWi			240		
115803	M2906-36AWi	600	2040	220	36"	11.5
115810	H2906-36AWi			240		
115827	M2907-40AWi	750	2550	220	40"	13
115834	H2907-40AWi			240		
115841	M2910-48AWi	1000	3413	220	48"	14
115858	H2910-48AWi			240		
115865	M2912-60AWi	1250	4250	220	60"	16
115872	H2912-60AWi			240		
115889	M2915-72AWi	1500	5100	220	72"	19
115896	H2915-72AWi			240		
115902	M2917-84AWi	1750	5950	220	80"	22
118002	H2917-84AWi			240		
118033	M2925-120AWi	2500	8532	220	120"	31
118040	H2920-120AWi			240		

Wireway Length Same As Baseboard Length



Manufactured in U.S.A.



## Features

- Available in white or ivory with stainless steel heating element and Aluminum fins.
- Painted 22 gauge steel front with 20 gauge junction boxes located on each end of the heater - junction boxes contain quick connect cable clamps and 6" ground lead wires.
- Over-temperature thermal limit extends entire length of heated area.
- A full length wireway provided along the back of the heater - enclosed conduit available.
- Heater can be mounted to the wall by using the key hole knockouts every 4" at the back of the heater.
- Optional In-Built thermostats field installed in the junction box.
- HEIGHT: 6" DEPTH: 2-1/2"

## Standard Models

UPC 686334	IVORY MODEL	UPC 686334	WHITE MODEL	WATTS	BTU's	VOLTS	AMPS	HEATER LENGTH (IN)	WT. (LBS.)
104302	E2903-024S	104999	E2903-024SW	375	1275	120	3.1	24	5
104319	F2903-024S	105002	F2903-024SW	375	1275	208	1.8		
104326	H2903-024S	105019	H2903-024SW	375 / 281	1275 / 955	240 / 208	1.6/1.4		
104333	G2903-024S	105026	G2903-024SW	375 / 281	1275 / 955	277 / 240	1.6/1.2	28	6
104340	E2905-028S	105033	E2905-028SW	500	1706	120	4.2		
104357	F2905-028S	105040	F2905-028SW	500	1706	208	2.4		
104364	H2905-028S	105057	H2905-028SW	500 / 375	1706 / 1275	240 / 208	2.1/1.8	36	7
104371	G2905-028S	105064	G2905-028SW	500 / 375	1706 / 1275	277 / 240	1.8/1.6		
104388	E2906-036S	105071	E2906-036SW	600	2040	120	5		
104395	F2906-036S	105088	F2906-036SW	600	2040	208	2.9	40	8
104401	H2906-036S	105095	H2906-036SW	600 / 450	2040 / 1530	240 / 208	2.5/2.2		
104418	G2906-036S	105101	G2906-036SW	600 / 450	2040 / 1530	277 / 240	2.2/1.9		
104425	E2907-040S	105118	E2907-040SW	750	2550	120	6.3	48	10
104432	F2907-040S	105125	F2907-040SW	750	2550	208	3.6		
104449	H2907-040S	105132	H2907-040SW	750 / 563	2550 / 1914	240 / 208	3.1/2.7		
104456	G2907-040S	105149	G2907-040SW	750 / 563	2550 / 1914	277 / 240	2.7.2.6	60	12
104463	E2910-048S	105156	E2910-048SW	1000	3413	120	8.3		
104470	F2910-048S	105163	F2910-048SW	1000	3413	208	4.8		
104487	H2910-048S	105170	H2910-048SW	1000 / 750	3413 / 2550	240 / 208	4.2/3.6	72	14
104494	G2910-048S	105187	G2910-048SW	1000 / 750	3413 / 2550	277 / 240	3.6/3.1		
104500	G2907-048S	105194	G2907-048SW	750	2550	277	3.4		
104517	E2912-060S	105200	E2912-060SW	1250	4250	120	10.4	84	16
103008	F2912-060S	105217	F2912-060SW	1250	4250	208	6		
103015	H2912-060S	105224	H2912-060SW	1250 / 938	4250 / 3189	240 / 208	5.2/4.5		
103022	G2912-060S	105231	G2912-060SW	1250 / 938	4250 / 3189	277 / 240	4.5/3.9	96	18
103039	G2909-060S	105248	G2909-060SW	938	3189	277	3.4		
103046	E2915-072S	105255	E2915-072SW	1500	5100	120	12.5		
103053	F2915-072S	105262	F2915-072SW	1500	5100	208	7.2	120	22
103060	H2915-072S	105279	H2915-072SW	1500 / 1125	5100 / 3825	240 / 208	6.3/4.7		
103077	G2915-072S	105286	G2915-072SW	1500 / 1125	5100 / 3825	277 / 240	5.4/4.7		
103084	G2911-072S	105293	G2911-072SW	1125	3825	277	4.1	84	16
103091	F2917-084S	105309	F2917-084SW	1750	5950	208	8.4		
103107	H2917-084S	105316	H2917-084SW	1750 / 1313	5950 / 4464	240 / 208	7.3/6.3		
103114	G2917-084S	105323	G2917-084SW	1750 / 1313	5950 / 4464	277 / 240	6.3/5.5	96	18
103121	G2913-084S	105330	G2913-084SW	1313	4464	277	4.7		
103138	F2920-096S	105347	F2920-096SW	2000	6826	208	9.6		
103145	H2920-096S	105354	H2920-096SW	2000 / 1500	6826 / 5100	240 / 208	8.3/7.2	120	22
103152	G2920-096S	105361	G2920-096SW	2000 / 1500	6826 / 5100	277 / 240	7.2/6.3		
103169	G2915-096S	105378	G2915-096SW	1500	5100	277	5.4		
103213	F2925-120S	105422	F2925-120SW	2500	8532	208	12	120	22
103220	H2925-120S	105439	H2925-120SW	2500 / 1875	8532 / 6375	240 / 208	10.4/9.0		
103237	G2925-120S	105446	G2925-120SW	2500 / 1875	8532 / 6375	277 / 240	9.0/7.8		
103244	G2918-120S	105453	G2918-120SW	1875	6375	277	6.8		





Manufactured in U.S.A.



## Features

- Bankers bronze with stainless steel heating element and Aluminum fins.
- Powder coated 22 gauge steel front with 20 gauge junction boxes located on each end of the heater - junction boxes contain quick connect cable clamps and 6" ground lead wires.
- Standard inlet and outlet wire guards.
- Over-temperature thermal limit extends entire heated length of unit.
- A full length wireway provided along the back of the heater.
- Heater can be mounted to the wall by using the key hole knockouts every 4" at the back of the heater.
- Optional In-Built thermostats field installed in the junction box.
- HEIGHT: 6" DEPTH: 2-1/2"

## Standard Models

UPC# 686334	BRONZE MODEL	WATTS	BTU's	VOLTS	AMPS	HEATER LENGTH (IN)	WEIGHT (LBS)
103831	E2903-024C	375	1275	120	3.1	24	5
103848	F2903-024C	375	1275	208	1.8		
103855	H2903-024C	375 / 281	1275 / 955	240 / 208	1.6 / 1.4		
103862	G2903-024C	375 / 281	1275 / 955	277 / 240	1.6 / 1.2	28	6
103879	E2905-028C	500	1706	120	4.2		
103886	F2905-028C	500	1706	208	2.4		
103893	H2905-028C	500 / 375	1706 / 1275	240 / 208	2.1 / 1.8	36	7
103909	G2905-028C	500 / 375	1706 / 1275	277 / 240	1.8 / 1.6		
103916	E2906-036C	600	2040	120	5.0		
103923	F2906-036C	600	2040	208	2.9	40	8
103930	H2906-036C	600 / 450	2040 / 1530	240 / 208	2.5 / 2.2		
103947	G2906-036C	600 / 450	2040 / 1530	277 / 240	2.2 / 1.9		
103954	E2907-040C	750	2550	120	6.3	48	10
103961	F2907-040C	750	2550	208	3.6		
103978	H2907-040C	750 / 563	2550 / 1914	240 / 208	3.1 / 2.7		
103985	G2907-040C	750 / 563	2550 / 1914	277 / 240	2.7 / 2.6	60	12
103992	E2910-048C	1000	3413	120	8.3		
104005	F2910-048C	1000	3413	208	4.8		
104012	H2910-048C	1000 / 750	3413 / 2550	240 / 208	4.2 / 3.6	72	14
104029	G2910-048C	1000 / 750	3413 / 2550	277 / 240	3.6 / 3.1		
104036	G2907-048C	750	2550	277	3.4		
104043	E2912-060C	1250	4250	120	10.4	84	16
104050	F2912-060C	1250	4250	208	6.0		
104067	H2912-060C	1250 / 938	4250 / 3189	240 / 208	5.2 / 4.5		
104074	G2912-060C	1250 / 938	4250 / 3189	277 / 240	4.5 / 3.9	96	18
104081	G2909-060C	938	3189	277	3.4		
104098	E2915-072C	1500	5100	120	12.5		
104104	F2915-072C	1500	5100	208	7.2	120	22
104111	H2915-072C	1500 / 1125	5100 / 3825	240 / 208	6.3 / 4.7		
104128	G2915-072C	1500 / 1125	5100 / 3825	277 / 240	5.4 / 4.7		
104135	G2911-072C	1125	3825	277	4.1	84	16
104142	F2917-084C	1750	5950	208	8.4		
104159	H2917-084C	1750 / 1313	5950 / 4464	240 / 208	7.3 / 6.3		
104166	G2917-084C	1750 / 1313	5950 / 4464	277 / 240	6.3 / 5.5	96	18
104173	G2913-084C	1313	4464	277	4.7		
104180	F2920-096C	2000	6826	208	9.6		
104197	H2920-096C	2000 / 1500	6826 / 5100	240 / 208	8.3 / 7.2	120	22
104203	G2920-096C	2000 / 1500	6826 / 5100	277 / 240	7.2 / 6.3		
104210	G2915-096C	1500	5100	277	5.4		
104265	F2925-120C	2500	8532	208	12.0	84	16
104272	H2925-120C	2500 / 1875	8532 / 6375	240 / 208	10.4 / 9.0		
104289	G2925-120C	2500 / 1875	8532 / 6375	277 / 240	9.0 / 7.8		
104296	G2918-120C	1875	6375	277	6.8		

## International Models

UPC# 686334	BRONZE MODEL	WATTS	BTU's	VOLTS	AMPS	HEATER LENGTH (IN)	WEIGHT (LBS)
118057	M2903-024CI	375	1275	220	1.7	24	5
118064	H2903-024CI			240	2.40		
118071	M2905-028CI	500	1706	220	2.3	28	6
118088	H2905-028CI			240	2.1		
118095	M2906-036CI	600	2040	220	2.7	36	7
118101	H2906-036CI			240	2.5		
118118	M2907-040CI	750	2550	220	3.4	40	8
118125	H2907-040C			240	3.1		
118132	M2910-048CI	1000	3413	220	4.6	48	10
118149	H2910-048CI			240	4.2		
118156	M2912-060CI	1250	4250	220	5.7	60	12
118163	H2912-060C			240	5.2		
118170	M2915-072CI	1500	5100	220	6.8	72	14
118187	H2915-072CI			240	6.3		
118194	M2917-084CI	1750	5950	220	8.0	84	16
118200	H2917-084CI			240	7.3		
118217	M2920-096CI	2000	6826	220	9.1	96	18
118224	H2920-096CI			240	8.3		
118231	M2925-120CI	2500	8532	220	11.4	120	22
118248	H2925-120CI			240	10.4		

# Electric Baseboard - Accessories

## In-Built Thermostat Kits- With Two Cover Plates

IVORY & WHITE		DESCRIPTION	WEIGHT (LBS)
UPC 686334	MODEL NUMBER		
105460	TBS	SPST-In-Built 22A @ 120-240V 18A @ 277V	1/2 lbs.
502702	TBS-TP	SPST-In-Built 22A @ 120-240V 18A @ 277V Tamperproof	
105477	TBD	DPST-In-Built 22A @ 120-240V 18A @ 277V	1/2 lbs.
502719	TBD-TP	DPST-In-Built 22A @ 120-240V 18A @ 277V Tamperproof	

## Field Installed Accessories

DESCRIPTION	IVORY		WHITE		BANKERS BRONE		WEIGHT (LBS)
	UPC 686334	MODEL	UPC 686334	MODEL	UPC 686334	MODEL	
Disconnect Switch, 20 Amp, 120-277V	106108	DS	106115	DSW	106122	DSB	1 lb.
Corner Sections	105491	CS	105507	CSW	105514	CSB	
1" Joiner Kits	105521	JK	105538	JKW	105545	JKB	1/4 lb.
6" Blank Relay Section (Relay Not Included)**	105552	LVRS	105569	LVRWS	105576	LVRBS	1 1/2 lbs.
Receptacle Section (Baseboard Mounted) 15 Amp 120 VAC	105583	BDR115	105590	BDR115W	105606	BDR115B	1/4 lb.
Receptacle Section (Mounted in 6" Blank) 15 Amp 120 VAC	105613	DR115	105620	DR115W	105637	DR115B	2 lbs.
Transfer Switch (Mounted in 6" Blank) 16 Amp 120 VAC	105644	SR120	105651	SR120W	105668	SR120B	
Transfer Switch (Mounted in 6" Blank) 16 Amp 240 VAC	105675	SR220	105682	SR220W	105699	SR220B	

\*\*Not for use with 24A06G-1 relay.

### Optional Wireway Covers

UPC 686334	MODEL	BASEBOARD LENGTH (in.)	COVER LENGTH (in.)	WEIGHT (LBS)
105705	WWA01	24	20	1
105712	WWA02	28	24	1.5
105729	WWA03	36	32	2
105736	WWA04	40	36	2.5
105743	WWA05	48	44	3
105750	WWA06	60	56	4
105767	WWA07	72	68	5
105774	WWA08	84	80	6
105781	WWA09	96	92	7
105798	WWA00	120	116	8

### Blank Sections

LENGTH	IVORY		WHITE		BANKERS BRONZE		WEIGHT (LBS)
	UPC	MODEL	UPC	MODEL	UPC	MODEL	
24"	105804	BBS024A	105903	BBS024AW	106009	BBS024C	5
28"	105811	BBS028A	105910	BBS028AW	106016	BBS028C	5 1/2
36"	105828	BBS036A	105927	BBS036AW	106023	BBS036C	6
40"	105835	BBS040A	105934	BBS040AW	106030	BBS040C	7
48"	105842	BBS048A	105941	BBS048AW	106047	BBS048C	8
60"	105859	BBS060A	105958	BBS060AW	106054	BBS060C	10
72"	105866	BBS072A	105965	BBS072AW	106061	BBS072C	12
84"	105873	BBS084A	105972	BBS084AW	106078	BBS084C	15
96"	105880	BBS096A	105989	BBS096AW	106085	BBS096C	17
120"	105897	BBS120A	105996	BBS120AW	106092	BBS120C	20

# 9100 Series - Radius Front Draft Barrier Heater

**ETL listed up to 250 Watts / foot for industrial, commercial, or residential applications.**



Manufactured in U.S.A.

## Features

- Standard colors, white or ivory.
- “UNI-LOCK” construction allows snap-fit, 2 piece installation.
- Units can be controlled by optional In-Built thermostat or can be constructed with relays and / or transformers for low voltage or line voltage wall thermostats
- Thermal protection by full length manual reset linear limits
- Optional duplex receptacle section
- Wiring junction boxes on each end of the unit
- Custom colors and finishes available (consult factory)
- Limited by max Amp draw of 25 Amps (with no controls).
- Additional charges may be incurred if changes are made after production has begun - consult factory.

## HOW TO DESIGNATE A MODEL:

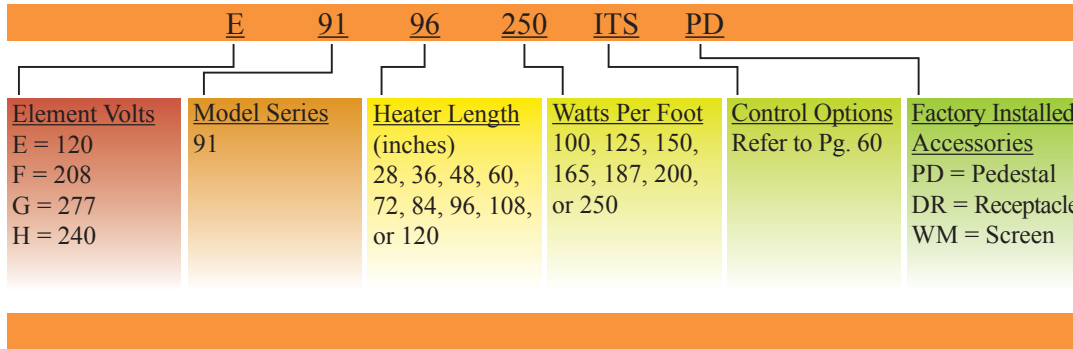

## Product Description

TECHNICAL INFORMATION	
Air Intake	Bottom
Air Discharge	Top
Min Mounting Height	3"
Max Watts / Foot	250
Max Allowable Amps	25 Amps (20 Amps with disconnect)
Voltage / Phase	120V/208V/240V/277V Single Phase

TECHNICAL INFORMATION	
Height	4 1/2"
Depth	3 1/8"
Length	28" to 120" in 1' increments
Cabinet Material	Aluminum
Gauge	14
Optional Controls That Can Be Built Into Unit	Thermostat and Disconnect Switch (Control Section Required for Relays)

## Standard Models

MODEL	UNIT LENGTH
9128	28"
9136	36"
9148	48"
9160	60"
9172	72"
9184	84"
9196	96"
91108	108"
91120	120"

MODEL	UNIT LENGTH
91BS012	12"
91BS024	24"
91BS036	36"
91BS048	48"
91BS060	60"
91BS072	72"
91BS084	84"
91BS096	96"
91BS108	108"
91BS120	120"

## Factory Installed Accessories

SUFFIX	DESCRIPTION
DR	Duplex Receptacle in 4" Extended Enclosure (not available with 120" heater)
PD	28" through 60" - 2 Required
	72" through 96" - 3 Required
	108" through 120" - 4 Required
WM	1/4" wire mesh under grill

## Field Installed Accessories

MODEL	DESCRIPTION
9100IC	Inside Corner Section 90° or 135°
9100OC	Outside Corner Section 90° or 135°
9100EC	Right or Left End Cap

Note: All models are suitable for International use

### CABINET

9100 Series shall be constructed of 14 gauge extruded 6063 Aluminum heat treated to T5 hardness. The uni-lock construction shall allow easy installation and access to back plate for wiring. The snap-fit front cover makes installation and service very simple. Custom factory enclosures to 1/16 inch increments are built for exact wall to wall fit up to 10 foot enclosure lengths. The 14 gauge back plate will have electrical knockouts for incoming power on each end adjacent to junction box. Pedestal mounted units will have incoming power connection through the pedestal on bottom of unit and will have smooth back for optional finished back. The die punched front cover will have no screw heads or fasteners.

### ELEMENTS

High mass sheathed element construction with Nickel-Chromium resistance wire embedded in compacted efficient die-electric to ensure proper heat transfer. Aluminum fins mechanically bonded to stainless steel tube allows for increased surface area and even heat transfer.

### LIMIT CONTROLS

Manual reset hydraulic thermal overload covers full length of heating element and shuts down heater when safe operating temperatures are exceeded.

### WIRING

Wiring shall be in either end of the enclosure. Wiring can be in the junction box or optional control section if additional controls are needed. Pedestal mounted units shall have 1-1/4" hole through the pedestal and in the bottom of the enclosure for incoming power wiring. All heaters have a factory supplied built in raceway for wiring from either end of the heater or for wiring of continuous heater connections.

### CONTROLS

Optional controls include single or double pole thermostat and disconnect switch that are factory wired in enclosed junction box on each end of heater enclosure. Relay, transformer relay and duplex receptacle options shall be mounted in extended length control section. **Control section will add to heater enclosure length.** The control section for the duplex receptacle will add 4" to enclosure length. The control section for other optional components or combinations of components will have two options (6" or 12") depending on controls required.

### APPLICATION

The 9100 series is ETL listed for commercial, industrial or residential applications on all units up to 250 Watts per foot.

### Product Dimensions

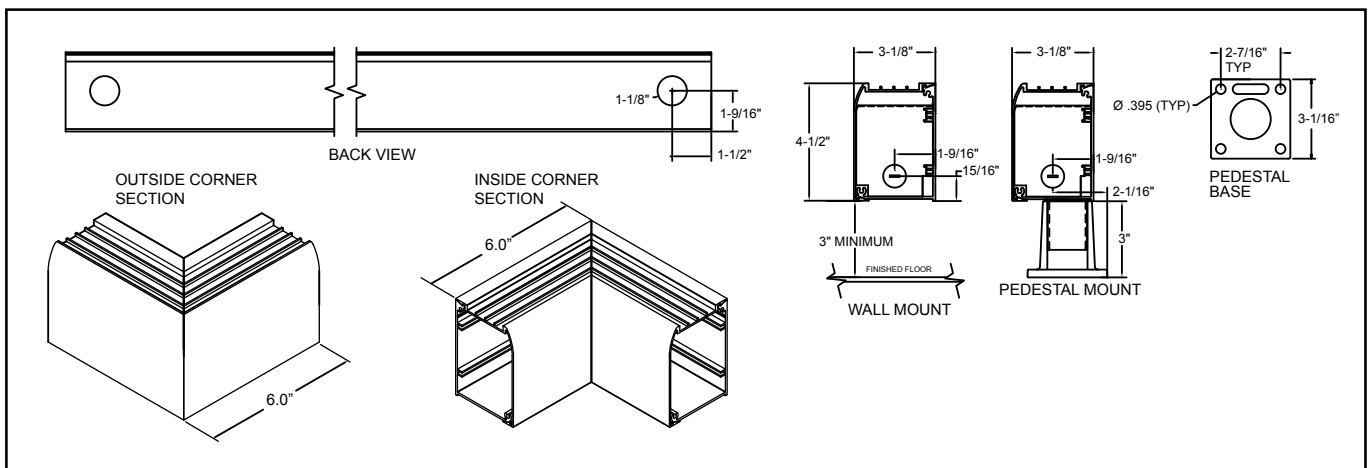



# 9300 Series - Radius Front Draft Barrier Heater

**ETL listed up to 750 Watts / foot for industrial or commercial applications.**



*Manufactured in U.S.A.*

## Features

- Lead and green compliance, 1 and 3 phase applications
- Industrial or commercial applications
- Standard color: Bankers Bronze (powder coated)
- Also available in other standard TPI colors and custom colors for an additional charge
- Uni-lock construction for snap fit 2 piece installation
- Temperature control can be in-built or wall mounted
- Thermal protection by full length manual reset linear limits
- Optional accessories include: duplex receptacle, and inside or outside corner sections for wall to wall custom fit.
- Additional charges may be incurred if changes are made after production has begun - consult factory.

### HOW TO DESIGNATE A MODEL:

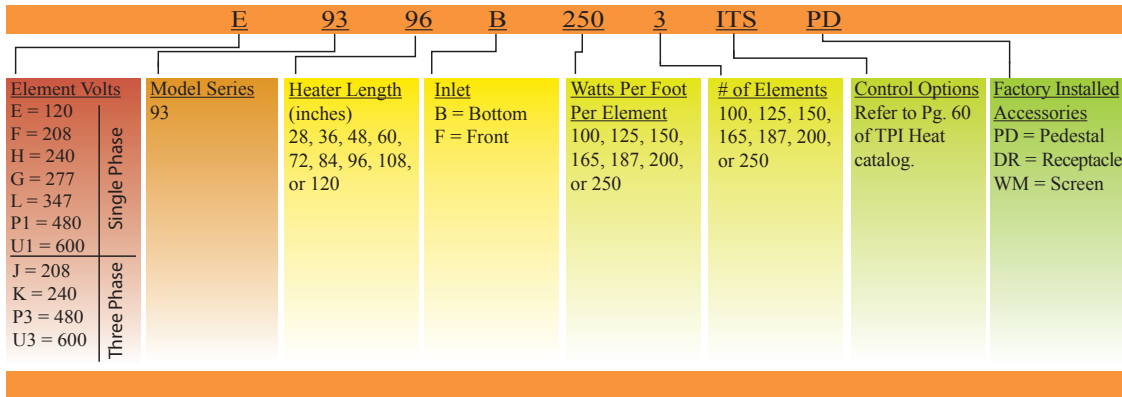

Note:

480V single phase units minimum 36" heated length; 600V single phase units minimum 48" heated length  
347-480-600 single phase and all three phase units are built with low voltage option factory installed

## Product Description

TECHNICAL INFORMATION	
Air Intake	Bottom / Front
Air Discharge	Top
Min Mounting Height	3" for bottom intake / 0" for front intake
Max Watts / Foot	750
Max Allowable Amps	25 without relay, 40 with relay
Voltage / Phase	120V/208V/240V/277V/347V,480V,600V Single Phase 208V,240V,480V,600V Three Phase

TECHNICAL INFORMATION	
Height	7.5"
Depth	6.15"
Length	28" to 120" in 1" increments
Cabinet Material	Aluminum
Material Gauge	12
Optional Controls That Can Be Built Into Unit	Thermostat, Disconnect Switch, Transformer (Control Section Required for Relays)

### Standard Models

MODEL	UNIT LENGTH	MODEL	UNIT LENGTH		
Heater	9328	28"	Blank Section	93BS012	12"
	9336	36"		93BS024	24"
	9348	48"		93BS036	36"
	9360	60"		93BS048	48"
	9372	72"		93BS060	60"
	9384	84"		93BS072	72"
	9396	96"		93BS084	84"
	93108	108"		93BS096	96"
	93120	120"		93BS108	108"
				93BS120	120"

Note: All models are suitable for International use

### Factory Installed Accessories

SUFFIX	DESCRIPTION
DR	Duplex Receptacle in 4" Extended Enclosure (not available with 120" heater)
PD	28" through 60" - 2 Required
	72" through 96" - 3 Required
	108" through 120" - 4 Required
WM	1/4" wire mesh under grill
IDS	30 Amp/240V Disconnect Switch
	40 Amp/600V Disconnect Switch

Note: If using line voltage thermostat on 1 phase heaters, you cannot exceed 25 Amps due to Amp rating of thermostat. 347, 480, and 600V can use 30 Amps with in-built thermostat.

### Field Installed Accessories

MODEL	DESCRIPTION
9300IC	Inside Corner Section 90° or 135°
9300OC	Outside Corner Section 90° or 135°
9300EC	Right or Left End Cap

### CABINET

9300 Series shall be constructed of 12 gauge extruded 6063 Aluminum heat treated to T5 hardness. The uni-lock construction shall allow easy installation and access to back plate for wiring. The snap-fit front cover makes installation and service very simple. Custom factory enclosures to 1/16 inch increments are built for exact wall to wall fit up to 10 foot enclosure lengths. The 12 gauge back plate will have electrical knockouts for incoming power on each end adjacent to junction box. Pedestal mounted units will have incoming power connection through the pedestal on bottom of unit and will have smooth back for optional finished back. The die punched front cover will have no screw heads or fasteners.

### ELEMENTS

High mass sheathed element construction with Nickel-Chromium resistance wire embedded in compacted efficient die-electric to ensure proper heat transfer. Aluminum fins mechanically bonded to stainless steel tube allows for increased surface area and even heat transfer.

### LIMIT CONTROLS

Manual reset hydraulic thermal overload covers full length of heating element and shuts down heater when safe operating temperatures are exceeded.

### WIRING

Wiring shall be in either end of the enclosure. Wiring can be in the junction box or optional control section if additional controls are needed. Pedestal mounted units shall have 1-1/4" hole through the pedestal and in the bottom of the enclosure for incoming power wiring. All heaters have a factory supplied built in raceway for wiring from either end of the heater or for wiring of continuous heater connections.

### CONTROLS

Optional controls include single or double pole thermostat and disconnect switch that are factory wired in enclosed junction box on each end of heater enclosure. Relay, transformer relay and duplex receptacle options shall be mounted in extended length control section. **Control section will add to heater enclosure length.** The control section for the duplex receptacle will add 4" to enclosure length. The control section for other optional components or combinations of components will have two options (6" or 12") depending on controls required.

### APPLICATION

The 9300 series is ETL listed for commercial or industrial applications on all units up to 750 Watts per foot on all units. 3 Phase units have a minimum of 300 Watts per foot.

## Product Dimensions

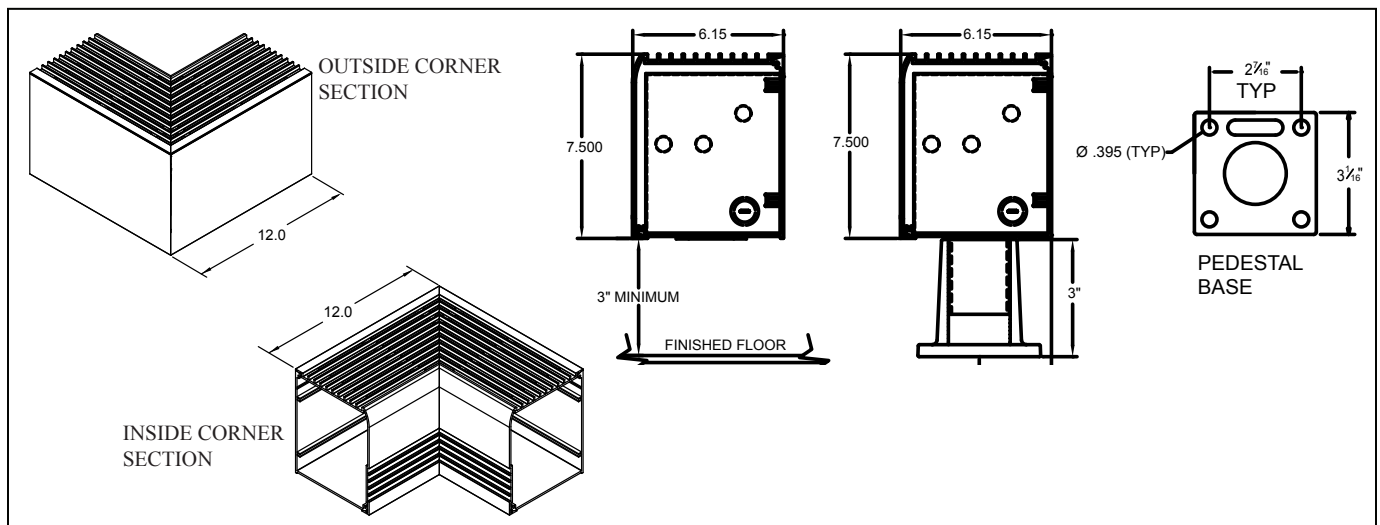

# Draft Barrier Heaters - General Product Information

**All Draft Barrier Heaters, unless otherwise noted, are build to order items. Consult factory for lead times. Additional charges may be incurred if changes are made after production has begun - consult factory.**

## Electric Draft Barrier Features

- “UNI-LOCK” construction allows snap-fit, 2 piece installation
- Heavy Gauge Aluminum Extruded enclosures, 6063 heat treated to T-5 hardness
  - a. DBT/DBF & RDBT-PD-12 gauge front & back
  - b. DBCT/DBCF- 10 gauge Front & Back
  - c. CB-14 gauge Front & Back
- ASHDB Series is 16 gauge Steel Front with 18 Steel gauge back
- 1/4” pencil proof discharge louvers
- Thermal protection by full length linear limits
- Multiple heaters, factory wired on same back plate, available in up to 10’ lengths
- Totally enclosed junction boxes
- Custom colors and finishes available (See Chart )
- Enclosures available for hydronic heating coils (consult factory for more information )

## How To Designate A Model

Digit	(Example)	MODEL NUMBER DESIGNATION - “ASI” DRAFT BARRIER
Digit 1=	DBT	Series Model Number ( DBT/DBF, CB, Etc.)
Digit 2=	PD	Use if Pedestals are Required* 2’ to 5’ Heaters require 2 pedestals 6’ to 8’ Heaters require 3 pedestals 9’ & 10’ Heaters require 4 pedestals
Digit 3=	4	Heated Length of Heater (for extended enclosure, specify amount of required enclosure on order write up, IE: 4’ Heated length w/ 2’6” of extended enclosure)
Digit 4=	250	Wattage per Linear foot ( may not exceed allowable wattages on specific models, refer to catalogue page to verify maximum WPF)
Digit 5=	ITS (etc)	Control Options ; Refer to List Price chart for available options ( Verify on each model which options may be factory installed )

Completed example: DBT-PD-4250-ITS

### NOTE:

- Extended enclosures and Blank Sections are NOT punched. When a Control Section is specified, ALWAYS allow for an extended enclosure to compensate for the 6” or 12” length of the Section required.
- Note on order when finished backs are required and add list adder to model list.
- **Total heater amperage must not exceed the 25-Amp rating of the high temperature limit at any voltage or wattage. This applies to all Sill Line Model Series.**

## Voltage & Wattage Specification

Voltage	Standard Wattages Per Foot	Heater Lengths
120-277	100, 125, 150, 165, 187, 200, 250*, 300, 333*, 375*	2’ through 10’

\*Units with Extended Enclosures may require more Pedestals than standard length, must verify length of heater after extended enclosures for total amount of pedestals. NOTE: All bottom inlet units must be mounted a minimum of 3 inches above finished floor.

Dual element models DBCT/DBCF and ASHDB. All elements are single phase. Consult factory for more information.

## Control Options

Suffix Designation	Description
CS 6	6” control section / will contain up to 2 control options
CS 12	12” control section / will contain up to 3 control options
ITS	Single Pole, 25 Amp integral thermostat, 120,208,240 & 277 Volts
ITD	Double Pole, 25 Amp integral thermostat, 120,208,240 & 277 Volts
IDS	Double Pole Disconnect, 20 Amp, 120, 208, 240 & 277 Volts
IDS 30	30 Amp disconnect (9300 Series)
IDS 40	40 Amp disconnect (9300 Series)
LVTR	Low voltage controls (trans & relay)
PR 120-277/24	Power Relay, 18 Amp tested, Must specify coil voltage Single Pole
PR 120-277/120	
PR 120-277/240	
ATR*	Single Pole, rated 25 Amps, 120 to 240 Volts, Contacts rated up to 277 Volts (must specify ) Coils are 24 Volt; 24 Volt transformer

## CUSTOM PAINT COLORS

### Durable Powder Coat Paint Finish

Bankers Bronze - standard color

Eggshell White

Black

Gray

Beige

Bronze Anodized\*

\*simulated powder

coat finish

Special Colors (5 lb. Increment)

### ANODIZING\*

\* 204R1 Clear; 313R1 Bronze and Black

\* Not suitable for International use

**Note:** Please refer to each model to verify how many controls may be integrally mounted, Control sections will add length to the heater. Must use control section with PR 240/24, PR 208/24, 208/208 and ATR

**Note:** If using line voltage thermostat on single phase heaters you cannot exceed 25 Amps due to Amp rating of thermostat. 347, 480, and 600V models can use up to 30 Amps with in-built thermostat.

# DBF / DBT Series

# DBCT / DBCF Series



Manufactured in U.S.A.



DBT Wall Mount  
Model-300 WPF Max.



DBF Floor Mount  
Model-250 WPF Max.

Cabinet Dimensions: 3-1/2" x 6" x 10" Maximum Length

**Not suitable for residential applications. Built to order: consult factory for lead time.**

MODEL	LENGTH	Color Availability (heater & finished back)		
DBF-2/DBT-2	2'	Clear Anodized	Color Anodized	Painted Bronze
DBF-3/DBT-3	3'			
DBF-4/DBT-4	4'			
DBF-5/DBT-5	5'			
DBF-6/DBT-6	6'			
DBF-7/DBT-7	7'			
DBF-8/DBT-8	8'			
DBF-9/DBT-9	9'			
DBF-10/DBT-10	10'			
Extended Enclosure (no color on finished back)				
<b>Blank Sections</b>				
DBF/DBT-100BS	1'			
DBF/DBT-200BS	2'			
DBF/DBT-300BS	3'			
DBF/DBT-400BS	4'			
DBF/DBT-500BS	5'			
DBF/DBT-600BS	6'			
DBF/DBT-700BS	7'			
DBF/DBT-800BS	8'			
DBF/DBT-900BS	9'			
DBF/DBT-1000BS	10'			

Accessories	Color Availability		
DBF/DBT IC / Inside Corner Section 90 - 180 Degrees	Clear Anodized	Color Anodized	Painted Bronze
DBF/DBT OC / Outside Corner Section 180 - 270 Degrees - 6" longest side			
DBF/DBT ECR / Right Hand End Cap DBF/DBT ECL / Left Hand End Cap			
DBF/DBT IECR / Inside Fitting Right End Cap DBF/DBT IECL / Inside Fitting Left End Cap			
DBF/DBT WT / 2" - 6" Wall Trim			
DBF/DBT SP / 1 1/2" Splice Plate			
DBF/DBT MF / Mullion Front up to 1'			
DBF/DBT IF / Inside Filler up to 1'			
3/4" Conduit Raceway (standard is 1/2")			
Mesh / 1/4" Wire Mesh under Grill			
Pedestals - specify 2" or 3"			
See Chart for required amount per Heater			

NOTE: DBF/DBT Series will permit a Thermostat mounted on one side and a Disconnect on the other side, more or other controls require a 6" or 12" control section. Typically, thermostats are mounted on left side of heater. Control Section will add to length of heater.



Manufactured in U.S.A.



DBCT Wall Mount  
Model-750 WPF Max.



DBCF Floor Mount  
Model-600 WPF Max.

Cabinet Dimensions: 5" x 7" x 10" Maximum Length

**Not suitable for residential applications. Built to order: consult factory for lead time.**

MODEL / LENGTH	WATTS/FT.	Color Availability (heater & finished back)		
DBCT-2/DBCF-2	to 250	Clear Anodized	Color Anodized	Painted Bronze
2'	251-750			
DBCT-3/DBCF-3	to 250			
3'	251-750			
DBCT-4/DBCF-4	to 250			
4'	251-750			
DBCT-5/DBCF-5	to 250			
5'	251-750			
DBCT-6/DBCF-6	to 250			
6'	251-750			
DBCT-7/DBCF-7	to 250			
7'	251-750			
DBCT-8/DBCF-8	to 250			
8'	251-750			
DBCT-9/DBCF-9	to 250			
9'	251-750			
DBCT-10/DBCF-10	to 250			
10'	251-750			
Extended Enclosure (no color on finished back)				
<b>Blank Sections</b>				
DBCT/DBCF-100BS	1'			
DBCT/DBCF-200BS	2'			
DBCT/DBCF-300BS	3'			
DBCT/DBCF-400BS	4'			
DBCT/DBCF-500BS	5'			
DBCT/DBCF-600BS	6'			
DBCT/DBCF-700BS	7'			
DBCT/DBCF-800BS	8'			
DBCT/DBCF-900BS	9'			
DBCT/DBCF-1000BS	10'			

Accessories	Color Availability		
DBCT/DBCF IC / Inside Corner Section 90 - 180 Degrees	Clear Anodized	Color Anodized	Painted Bronze
DBCT/DBCF OC / Outside Corner Section 180 - 270 Degrees - 6" longest side			
DBCT/DBCF ECR / Right End Plate DBCT/DBCF ECL / Left End Plate			
DBCT/DBCF IECR/ Right End Plate (inside fit) DBCT/DBCF IECL/ Left End plate (inside fit)			
DBCT/DBCF WT / Wall Trim 2" - 6"			
DBCT/DBCF SP / 1 1/2" Splice Plate			
DBCT/DBCF IF / Inside Filler (up to 1')			
3/4" Conduit Raceway (standard is 1/2")			
Mesh / 1/4" Wire Mesh under Grill			
Pedestals - specify 2" or 3"			
See Chart for required amount per Heater			

NOTE: DBCT/DBCF Series will permit a Thermostat mounted on one side and Disconnect on the other side, more or other controls require a 6" or 12" control section. Typically, Thermostats are mounted on left side of heater. Control Section will add to the length of heater.



# DBTS Series Draft Barrier Heaters

## Features



Manufactured in U.S.A.

- Bottom air intake.
- Maximum watts per foot: 300.
- Dimensions: Depth 2-5/8" x Height 4" Length 2' to 10'.
- 14 gauge Aluminum housing.
- Voltages: 120V / 208V / 240V / 277V - 1 Phase
- No controls can be added without adding a control section and extended enclosure.

**Not suitable for residential applications. 300 watts per foot maximum. Built to order: consult factory for lead time.**

## Standard Models

MODEL		LENGTH	MODEL		LENGTH
HEATER	DBTS-2	2'	BLANK SECTION	DBTS-100BS	1'
	DBTS-3	3'		DBTS-200BS	2'
	DBTS-4	4'		DBTS-300BS	3'
	DBTS-5	5'		DBTS-400BS	4'
	DBTS-6	6'		DBTS-500BS	5'
	DBTS-7	7'		DBTS-600BS	6'
	DBTS-8	8'		DBTS-700BS	7'
	DBTS-9	9'		DBTS-800BS	8'
	DBTS-10	10'		DBTS-900BS	9'
					DBTS-1000BS

## Accessories

MODEL	DESCRIPTION
DBTS IC	Inside Corner Section 90° - 180°
DBTS OC	Outside Corner Section 180° - 270° - 6" longest side
DBTS ECR	Right Hand End Cap
DBTS ECL	Left Hand End Cap
DBTS IECR	Inside Fitting Right End Cap
DBTS IECL	Inside Fitting Left End Cap
DBTS WT	Wall Trim 2" - 6"
DBTS SP	Splice Plate 1 1/2"
DBTS MF	Mullion Front up to 1'
Note on order	1/2" Conduit Raceway
	Mesh 1/4" Wire Mesh under grill
	Pedestals - specify 2" or 3"



Cabinet Dimensions: 7" x 6" x 10"  
Maximum Length

**Not suitable for residential applications. 300 Watts Per Foot Maximum. Pedestals included with unit. Rounded enclosure with flat top discharge. Special Build: consult factory for lead time.**

Manufactured in U.S.A.

MODEL	LENGTH	Color Availability		
RDBT-PD-2	2'	Clear Anodized	Color Anodized	Painted Bronze
RDBT-PD-3	3'			
RDBT-PD-4	4'			
RDBT-PD-5	5'			
RDBT-PD-6	6'			
RDBT-PD-7	7'			
RDBT-PD-8	8'			
RDBT-PD-9	9'			
RDBT-PD-10	10'			
Extended Enclosure				
Blank Sections				
RDBT-PD-100BS	1'			
RDBT-PD-200BS	2'			
RDBT-PD-300BS	3'			
RDBT-PD-400BS	4'			
RDBT-PD-500BS	5'			
RDBT-PD-600BS	6'			
RDBT-PD-700BS	7'			
RDBT-PD-800BS	8'			
RDBT-PD-900BS	9'			
RDBT-PD-1000BS	10'			

Accessories	Color Availability		
RDBT-PDIC / Inside Corner Section 90 - 180 Degrees	Clear Anodized	Color Anodized	Painted Bronze
RDBT-PDOC / Outside Corner Section 180 - 270 Degrees - 6" longest side			
RDBT-PDIECR/Inside Fitting Right End Cap			
RDBT-PDIECL/Inside Fitting Left End Cap			
3/4" Conduit Raceway (standard is 1/2")			
Mesh - 1/4" Wire Mesh under Grill			

NOTE: RDBT-PD Series will permit a Thermostat mounted on one side and a Disconnect on the other side. More or other controls require a 6" or 12" control section. Typically, Thermostats are mounted on the left side of heater. Control Sections will add to length of heater.

## CB Series



Manufactured in U.S.A.

**Not suitable for residential applications. Bottom inlet only. Built to order: consult factory for lead time.**

Cabinet Dimensions:  
2-5/8" x 4-1/2" x 10"  
Maximum Length

NOTE: CB Series will permit either a Thermostat or a Disconnect on only one side of the heater. More or other controls require a control section. Typically, Thermostats are mounted on the right side of heater. Control Sections will add to length of heater.

Model	Length	Color (heater & finished back)		
CB-2	2'	Clear Anodized	Color Anodized	Painted Bronze
CB-3	3'			
CB-4	4'			
CB-5	5'			
CB-6	6'			
CB-7	7'			
CB-8	8'			
CB-9	9'			
CB-10	10'			
Extended Enclosure (no color on finished back)				
Blank Sections				
CB-100BS	1'			
CB-200BS	2'			
CB-300BS	3'			
CB-400BS	4'			
CB-500BS	5'			
CB-600BS	6'			
CB-700BS	7'			
CB-800BS	8'			
CB-900BS	9'			
CB-1000BS	10'			

**Not suitable for residential applications. 500 Watts per foot maximum. 16 gauge Steel enclosure, 18 gauge backplate. Heights may vary from 8" up to 20." Bottom Intake / Top Discharge. Special build - consult factory for lead time.**



Cabinet Dimensions: 5-1/2" x 8"  
thru 20" x 10" Maximum Length.  
Cannot be Anodized

Manufactured in U.S.A.

MODEL / LENGTH	WATTS/FT.	Color Availability (heater & finished back)		
ASHDB-2	to 250	Clear Anodized	Color Anodized	Painted Bronze
2'	251-500			
ASHDB-3	to 250			
3'	251-500			
ASHDB-4	to 250			
4'	251-500			
ASHDB-5	to 250			
5'	251-500			
ASHDB-6	to 250			
6'	251-500			
ASHDB-7	to 250			
7'	251-500			
ASHDB-8	to 250			
8'	251-500			
ASHDB-9	to 250			
9'	251-500			
ASHDB-10	to 250			
10'	251-500			
Extended Enclosure (no color on finished back)				
Blank Sections				
ASHDB-8/20-100BS	1'			
ASHDB-8/20-200BS	2'			
ASHDB-8/20-300BS	3'			
ASHDB-8/20-400BS	4'			
ASHDB-8/20-500BS	5'			
ASHDB-8/20-600BS	6'			
ASHDB-8/20-700BS	7'			
ASHDB-8/20-800BS	8'			
ASHDB-8/20-900BS	9'			
ASHDB-8/20-1000BS	10'			

Accessories	Color Availability		
ASHDB IC / Inside Corner Section 90 - 180 Degrees	Clear Anodized	Color Anodized	Painted Bronze
ASHDB OC / Outside Corner Section 180 - 270 Degrees - 6" longest side			
ASHDB ECR / Right End Cap			
ASHDB ECL / Left End Cap			
ASHDB SP / 1 1/2" Splice Plate			
ASHDB WT / 2" - 6" Wall Trim			
3/4" Conduit Raceway ( standard is 1/2")			
Mesh / 1/4" Wire Mesh under Grill			
Pedestals - Specify 2" or 3"			
See Chart for required amount per Heater			

NOTE: ASHDB Series will permit a Thermostat mounted on one side and a Disconnect on the other side, more or other controls require a 6" or 12" control section. Typically, Thermostats are mounted on left side of heater. Control Section will add to length of heater.

Accessories	Color Availability		
CB IC / Inside Corner Section 90 - 180 Degrees	Clear Anodized	Color Anodized	Painted Bronze
CB OC / Outside Corner Section 180 - 270 Degrees - 6" longest side			
CB ECR / Right End Cap			
CB ECL / Left End Cap			
CB WT / Wall Trim 2" - 6"			
CB SP / Splice Plate 1 1/2"			
CB MF / Mullion Front up to 1'			
1/2" Conduit Raceway			
Mesh / 1/4" Wire Mesh under Grill			
Pedestals - specify 2" or 3"			
See Chart for required amount per Heater			

# MR Series Heavy Duty Metal Sheath Electric Infrared Heater

Heavy Duty Overhead Infrared Heaters for Indoor Spot Heating, Zone or Total Area Heating Applications

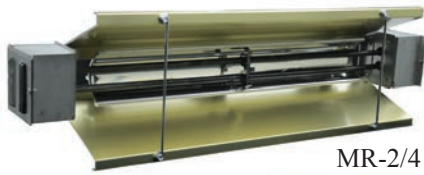

MR-2/4 KW

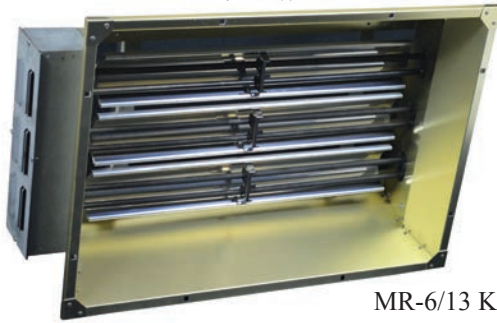

MR-6/13 KW



Manufactured in U.S.A.

- High-Density radiant heat, with 60° symmetric heat pattern.
- ETL Listed for suspended high-bay indoor applications
- Rugged straight metal sheath elements installed, great for high vibration areas.
- Gold anodized Aluminum housing for efficient, long term reflectivity & corrosion resistance.
- Terminal box with high-temp Silicone wire.
- Single or three phase wiring.
- "L" brackets included for chain suspension, or rigid mounting.

### MR Series Safety Note

Ground fault protection must be used. To avoid potential hazards use model GF-SK-1 ground fault sensing switch with these heaters. This device is designed to provide a reliable way to quickly terminate power to the heaters in the event of a ground fault occurrence.

### Standard Models



UPC# 686334	MODEL	KW	BTU'S	VOLTS	PHASE	AMPS		WT. (Lbs.)	Optional Wireguards				
						3-Ph	1-Ph		UPC# 686334	MODEL			
135177	MR-212-1	1.8*	6,143	120	1	N/A	15.0	9.0	449090	HDWG-2			
135184	MR-220-1	2.0	6,826	208	1		9.6						
135214	MR-224-1			240			8.5						
135221	MR-227-1			277			7.2						
135238	MR-248-1			480			4.2						
135245	MR-257-1			600			3.3						
135306	MR-420-1	4.5	15,359	208	1		21.6				15.0	449069	HDWG-4
135320	MR-424-1			240			18.8						
135337	MR-427-1			277			16.3						
135344	MR-448-1			480			9.5						
135351	MR-457-1			600		7.5							
135368	MR-620-3	6.0	20,478	208	3 or 1	17.0	29.0	27.0	449076	HDWG-6			
135375	MR-624-3			240		14.5	25.0						
135382	MR-627-3			277		N/A	21.7						
135412	MR-648-3			480		7.5	13.0						
135429	MR-657-3			600		5.8	10.0						
135115	MR-1320-3	13.5	46,076	208	3	37.5	N/A	43.0	449083	HDWG-13			
135122	MR-1324-3			240		33.0							
135139	MR-1327-3			277	N/A	48.8							
135153	MR-1348-3			480	3 or 1	17.0	29.0						
135160	MR-1357-3			600		13.6							
135252	MR-2720-3	27*	92,151	208	3	74.8	N/A	288.0 Crated	883047	HDWG-27			
135269	MR-2724-3			240		64.8							
135283	MR-2748-3			480		32.4							
135290	MR-2757-3			600		26.7							

Note: Some 3-Phase models can be field converted to single phase operation.

### Heavy Duty Metal Sheath Infrared Control Options

#### CONTROL FEATURES:

- (GF-SK-1) Positive "off" and built-in "on/off" rocker switch illuminates "red" during operation.
- Controls cannot be mounted directly on unit. Must use 6" minimum threaded conduit.

UPC 686334	MODEL	DESCRIPTION	RATING (VAC)	Dimensions (In)			WT. (lbs.)	
				Ht.	Wd.	Dp.		
	486026	GF-SK-1	Ground Fault Sensing Switch	208V - 600V 50A	10.3	10.3	5.0	12
	589376	DC-SK-1	Disconnect Switch	120V - 600V 50A	5.0	6.0	4.0	5

# MR Series Heavy Duty Metal Sheath Electric Infrared Heater

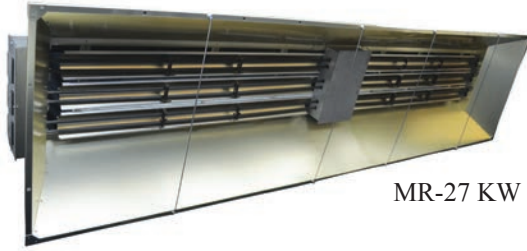

MR-27 KW

Note: The MR-27 Series includes (2) Terminal Box Assemblies, located on each end of the heater, requiring an electrical service to each end.



Manufactured in U.S.A.

## MR Series Dimensions & Reflector Pattern

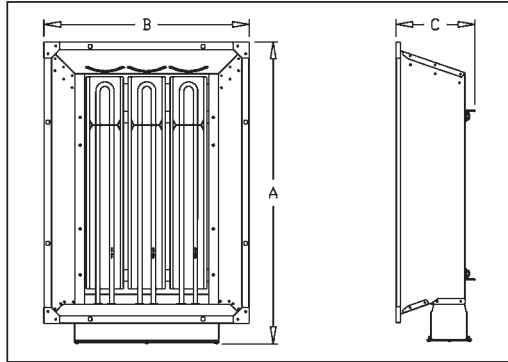

SERIES	DIMENSIONS (in.)		
	A LENGTH	B WIDTH	C DEPTH
MR-2	28	9	7.25
MR-4	48.5	9	7.25
MR-6	30	19.88	7.5
MR-13	50.5	19.88	7.5
MR-27	96.75	28.25	14.88

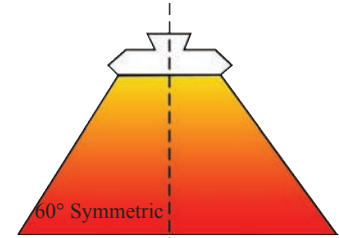

NOTE: Take into account that the MR Series is designed with a 60° symmetrical reflector heat pattern. The sizing chart can assist you based upon your mounting height.

## Mounting Clearances & Recommended Mounting Height

Mounting Clearances		Recommended Mounting Height	
All MR Models	24" from ceiling 36" from vertical surface & from another heater 72" from face of heater to combustible surface	1.8 & 2.0 KW	8' - 10'
		4.5 KW	8' - 12'
		6.0 KW	10' - 14'
		13.5 KW	12' - 16'
MR-27 Only	87" from face of heater to combustible surface	27.0 KW	15' - 30'

## Sizing Chart

Mounting Height	Heater Model	Length	Wide	Coverage (Sq. Ft.)	Watts / Sq. Ft.
8'	MR-2	8	8	64	31.3
	MR-4	9	8	72	62.5
10'	MR-2	11	10	110	18.2
	MR-4	11	10	110	40.9
	MR-6	12	10	120	50.0
12'	MR-4	12	11.5	138	32.6
	MR-6	14	12	168	35.7
	MR-13	15	13	195	69.2
14'	MR-6	16	14	224	26.8
	MR-13	18	16	288	46.9
16'	MR-6	18	16	288	20.8
	MR-13	21	18	378	35.7
	MR-27	24	19	456	59.2
18'	MR-13	23	20	460	29.3
	MR-27	28	20	560	48.2
20'	MR-27	28	23	644	41.9
24'	MR-27	33	27	891	30.3
30'	MR-27	41	32	1312	20.6

## Product Specifications

### Housing:

.040 Gold anodized Aluminum housing for efficient, long-term reflectivity and corrosion resistance. High-density radiant heat. Housing is ETL Listed for indoor, dry environment applications only.

### Reflector:

60 degree symmetric heat pattern.

### Elements:

Rugged straight metal sheath elements. .430" diameter Incoloy 840 metal sheath. Nickel-Chrome alloy coiled filament imbedded within a Magnesium Oxide insulating powder and threaded end terminations. Available wattages in 1800, 2000, and 4500 Watts per element. Available in standard voltages from 120 to 600 Volts.

### Controls:

Heavy Duty, Metal Sheath heaters are not manufactured with any control device on the unit. All controls and accessories should be specified as remote mounted. Please consult the technical sales department of factory for help in determining applicable controls. Please follow installation instructions that accompany each heater.

### Accessories:

Wire guards and power contactor panels.



# TH & THSS Series Mul-T-Mount Electric Infrared Heater

Overhead Infrared Heaters for Snow & Ice Control, Outdoor Spot Heating & All Indoor Heating Applications



## Product Description

AVAILABLE IN 2 LAMP BROWN ENAMEL OR STAINLESS STEEL, OR 3 LAMP STAINLESS STEEL.

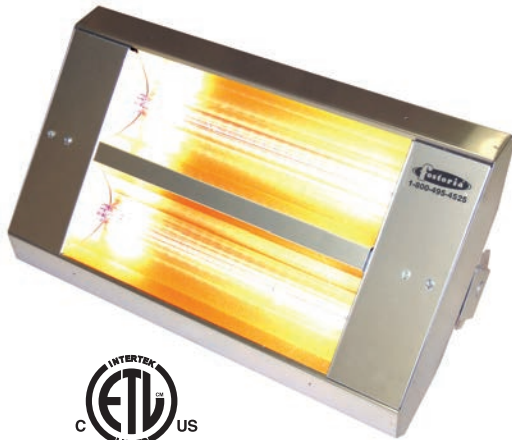

Manufactured in U.S.A.

- Listed for suspended, totally exposed (outdoor), high-bay (indoor) comfort heating and exterior snow & ice control applications.
- Listed for recessed applications.
- 20 gauge painted steel or stainless steel housings.
- Gold anodized Aluminum reflectors & end caps.
- 50% higher Watt densities for 3-element units.
- 2-Lamp wiring, single phase.
- 3-Lamp wiring, three or single phase.
- Stainless steel models have non-corrosive housing, hardware and brackets; no ferrous metals used in the unit. Durable in harsh atmospheres & outdoor environments.
- High temperature lead wires.
- Clear Quartz Lamp(s) Included.

### New Feature:

In-Built surface mounting brackets allows for fixture adjustment up to 45° horizontal tilt.

In-built surface mounting brackets attached to the top wiring channel.

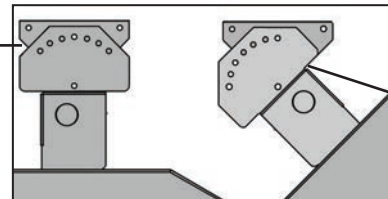

0 to 45° tilt @ 15° increments

## Product Dimensions

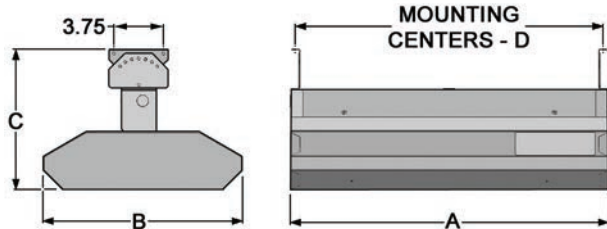

Mul-T-Mount Series	Dimensions (in.)			
	A Length	B Width	C Height	D Mtg. Ctr.
222	24"	15"	10-7/8"	23-1/2"
342	33"	15"	10-7/8"	32-1/2"
462	46"	15"	10-7/8"	45-1/2"
223	24"	21-1/2"	10-7/8"	23-1/2"
343	33"	21-1/2"	10-7/8"	34"
463	46"	21-1/2"	10-7/8"	45-1/2"

## Mounting Clearances & Recommended Mounting Height

Mounting Clearances		Recommended Mounting Height	
2 & 3 Lamp Models	3" from ceiling	30° Symmetric & A30° Asymmetric Reflector - Indoor	14' - 30'
	24" from vertical surface	60° Symmetric & A60° Asymmetric Reflector - Indoor	12' - 18'
2 Lamp Models	72" from face of heater to combustible surface	90° Symmetric Reflector - Indoor	8' - 12'
3 Lamp Models	96" from face of heater to combustible surface	30° Symmetric & A30° Asymmetric Reflector - Outdoor	8' - 10'

## Reflector Patterns

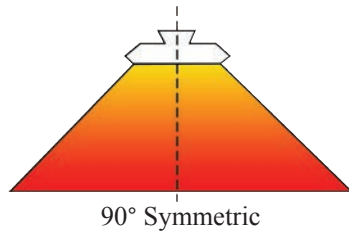
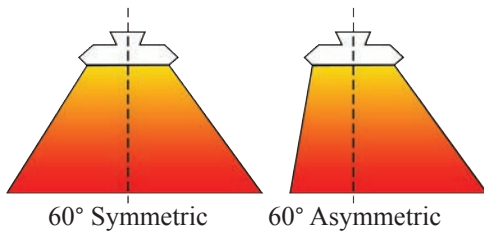
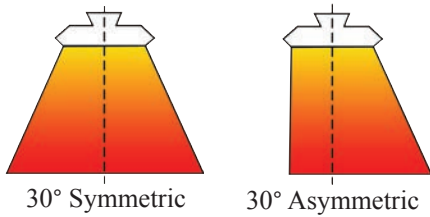

## Product Specifications

**Series:**

222, 342, 462 (Painted Version) 2-lamp  
 222, 342, 462 (Stainless Steel Version) 2-lamp  
 223, 343, 463 (Stainless Steel Version) 3-lamp

**Housing:**

20 gauge Galvanized Steel with a baked on, brown enamel (painted) finish. Housing is ETL Listed for both indoor and totally exposed outdoor applications.

20 gauge Stainless Steel for durability and corrosion-resistance. Housing is ETL Listed for both indoor and totally exposed outdoor applications.

**Reflectors and End Caps:**

.040 Gold anodized Aluminum reflectors and end caps for superior reflectivity. Five choices of reflector patterns including 30 degree narrow (symmetric & asymmetric), 60 degree medium (symmetric & asymmetric), and 90 degree wide (symmetric).

**Elements:**

Clear quartz lamps. Coiled tungsten filament located within a sealed quartz envelope, halogen filled, with porcelain end caps and 6" wire pigtail leads. 96% radiant delivered efficiency with high moisture and thermal shock resistance. Instantaneous heat-up and cool-down performance. Available wattages from 500 to 3800 Watts per element. Available voltages from 120 to 600 Volts.

**Controls:**

Mul-T-Mount heaters are not manufactured with any control device on the unit. All controls are accessories and should be specified as such. Please consult the technical sales department of factory for help in determining applicable controls. Please follow installation instructions that accompany each heater.

**Accessories:**

Recessed mounting frames (painted or stainless steel), adjustable mounting brackets (stainless steel only), vertical mounting brackets (stainless steel only), wire guards, thermostats, snow detectors, SCR controllers, and power contactor panels.

## Sizing Chart

Reflective Pattern (°)	Heater Output (kW)	# of Qiz. Lamps	Mounting Heights (FT.)							Watts Delivered per Square Foot							
			8	10	12	14	16	18	20	Mounting Heights (FT.)							
			Heat Pattern Coverage @ Floor Level							8	10	12	14	16	18	20	
			L x W	L x W	L x W	L x W	L x W	L x W	L x W	L x W							
30°	3.2	2 - Quartz Lamp Heaters	5.5 x 4	6.5 x 5.5	7.5 x 6.5	8.5 x 7.5	9.5 x 8.5	10.5 x 9.5	11.5 x 10.5		145.5	89.5	65.6	50.2	39.6	32.1	26.5
60°	3.2		10.5 x 9.5	13 x 12	15 x 14	17 x 16					32.1	20.5	15.2	11.8	-	-	-
90°	3.2		17 x 16	21 x 20	N/R	N/R					11.8	7.6	-	-	-	-	-
30°	5.0		6 x 4	7.5 x 5.5	8.5 x 6.5	9.5 x 7.5	10.5 x 8.5	11.5 x 9.5	12.5 x 10.5		208.3	121.2	90.5	70.2	56.0	45.8	38.1
60°	5.0		11.5 x 9.5	14 x 12	16 x 14	18 x 16	20.5 x 18.5	23 x 21			45.8	29.8	22.3	17.4	13.2	10.4	-
90°	5.0		18 x 16	22 x 20	26 x 24	N/R	N/R	N/R			17.4	11.4	8.0	-	-	-	-
30°	7.3		N/R	8.5 x 5.5	9.5 x 6.5	10.5 x 7.5	11.5 x 8.5	12.5 x 9.5	13.5 x 10.5		-	156.1	118.2	92.7	74.7	61.5	51.5
60°	7.3		12 x 10.5	15 x 12	17 x 14	19 x 16	21.5 x 18.5	24 x 21			57.9	40.6	30.7	24.0	18.4	14.5	-
90°	7.3		19 x 16	23 x 20	27 x 24	N/R	N/R	N/R			24.0	15.9	11.3	-	-	-	-
30°	4.8	3 - Quartz Lamp Heaters	5.5 x 5	6.5 x 6.5	7.5 x 7.5	8.5 x 8.5	9.5 x 9.5	10.5 x 10.5	11.5 x 11.5		174.5	113.6	85.3	66.4	53.2	43.5	36.3
60°	4.8		10.5 x 10.5	13 x 13	15 x 15	17 x 17	21 x 21				43.5	28.4	21.3	16.6	10.9	-	-
90°	4.8		17 x 17	21 x 21	N/R	N/R	N/R				16.6	10.9	-	-	-	-	-
30°	7.5		N/R	7.5 x 6.5	8.5 x 7.5	9.5 x 8.5	10.5 x 9.5	11.5 x 10.5	12.5 x 11.5		-	153.8	117.6	92.9	75.2	62.1	52.2
60°	7.5		11.5 x 10.5	14 x 13	16 x 15	18 x 17	20.5 x 19.5	23 x 22			62.1	41.2	31.3	24.5	18.8	14.8	-
90°	7.5		18 x 17	22 x 21	26 x 25	N/R	N/R	N/R			24.5	16.2	11.5	-	-	-	-
30°	10.95		N/R	8.5 x 6.5	9.5 x 7.5	10.5 x 8.5	11.5 x 9.5	12.5 x 10.5	13.5 x 11.5		-	198.2	153.7	122.7	100.2	83.4	70.5
60°	10.95		12 x 11	15 x 13	17 x 15	19 x 17	21.5 x 19.5	24 x 22			83.0	56.2	42.9	33.9	26.1	20.7	-
90°	10.95		19 x 17	23 x 21	27 x 25	N/R	N/R	N/R			33.9	22.7	16.2	-	-	-	-

# TH & THSS Series Mul-T-Mount Electric Infrared Heater



## 2 Lamp Mul-T-Mount Series Brown Enamel Or Stainless Steel With 2 Clear Quartz Lamps Included

BROWN HOUSING		STAINLESS STEEL HOUSING		KW	BTU'S	VOLTS	REFLECTOR PATTERN	Replacement Element	WT. (Lbs.)
UPC# 686334	MODEL	UPC# 686334	MODEL						
444163	222-30-TH-208V	444408	222-30-THSS-208V	3.2	10,922	208	30° Symmetrical	63016209	20
444170	222-30-TH-240V	444415	222-30-THSS-240V			240		63016249	
444187	222-30-TH-277V	444422	222-30-THSS-277V			277		63016279	
481380	222-30-TH-480V	481434	222-30-THSS-480V			480		63016489	
444194	222-A30-TH-208V	444439	222-A30-THSS-208V			208	30° Asymmetrical	63016209	
444200	222-A30-TH-240V	444446	222-A30-THSS-240V			240		63016249	
444217	222-A30-TH-277V	444453	222-A30-THSS-277V			277		63016279	
481410	222-A30-TH-480V	481465	222-A30-THSS-480V			480	63016489		
444224	222-60-TH-208V	444460	222-60-THSS-208V			208	60° Symmetrical	63016209	
444231	222-60-TH-240V	444477	222-60-THSS-240V			240		63016249	
444248	222-60-TH-277V	444484	222-60-THSS-277V			277		63016279	
481397	222-60-TH-480V	481441	222-60-THSS-480V			480	63016489		
444255	222-A60-TH-208V	444491	222-A60-THSS-208V			208	60° Asymmetrical	63016209	
444262	222-A60-TH-240V	444507	222-A60-THSS-240V			240		63016249	
444279	222-A60-TH-277V	444514	222-A60-THSS-277V			277		63016279	
481427	222-A60-TH-480V	481472	222-A60-THSS-480V			480	63016489		
443296	222-90-TH-208V	444521	222-90-THSS-208V			208	90° Symmetrical	63016209	
444286	222-90-TH-240V	444538	222-90-THSS-240V			240		63016249	
444293	222-90-TH-277V	444545	222-90-THSS-277V			277		63016279	
481403	222-90-TH-480V	481458	222-90-THSS-480V			480	63016489		
481083	342-30-TH-208V	480932	342-30-THSS-208V	5.0	17,065	208	30° Symmetrical	63025209	25
481090	342-30-TH-240V	480949	342-30-THSS-240V			240		63025249	
802611	342-30-TH-480V	802635	342-30-THSS-480V			480		63025489	
481175	342-A30-TH-208V	481021	342-A30-THSS-208V			208	30° Asymmetrical	63025209	
481182	342-A30-TH-240V	481038	342-A30-THSS-240V			240		63025249	
444316	342-A30-TH-480V	444569	342-A30-THSS-480V			480	63025489		
481113	342-60-TH-208V	480963	342-60-THSS-208V			208	60° Symmetrical	63025209	
481120	342-60-TH-240V	480970	342-60-THSS-240V			240		63025249	
802918	342-60-TH-480V	802932	342-60-THSS-480V			480	63025489		
481205	342-A60-TH-208V	481052	342-A60-THSS-208V			208	60° Asymmetrical	63025209	
481212	342-A60-TH-240V	481069	342-A60-THSS-240V			240		63025249	
444330	342-A60-TH-480V	444583	342-A60-THSS-480V			480	63025489		
481144	342-90-TH-208V	480994	342-90-THSS-208V			208	90° Symmetrical	63025209	
481151	342-90-TH-240V	481007	342-90-THSS-240V			240		63025249	
803212	342-90-TH-480V	803236	342-90-THSS-480V			480		63025489	
802710	462-30-TH-480V	802734	462-30-THSS-480V			7.3	24,915	480	
444361	462-A30-TH-480V	444613	462-A30-THSS-480V	30° Asymmetrical	63036489				
803014	462-60-TH-480V	803038	462-60-THSS-480V	60° Symmetrical	63036489				
444385	462-A60-TH-480V	444637	462-A60-THSS-480V	60° Asymmetrical	63036489				
803311	462-90-TH-480V	803335	462-90-THSS-480V	90° Symmetrical	63036489				

**NOTE:** Consult the factory, the product instruction manual, or a licensed electrician for 3-phase wiring of all 2-element heaters.

# TH & THSS Series Mul-T-Mount Electric Infrared Heater

3 Lamp Mul-T-Mount Series  
Brown Enamel Or Stainless Steel Housing With 3 Clear Quartz Lamps Included



Manufactured in U.S.A.

**NOTE:**

- 600-Volt Models also available, contact factory for more information.
- Asymmetrical pattern units are also available for 30° & 60°

BROWN HOUSING		STAINLESS STEEL HOUSING		KW	BTU'S	VOLTS	REFLECTOR PATTERN	Replacement Element	WT. (LBS.)			
UPC# 686334	MODEL	UPC# 686334	MODEL									
487481	223-30-TH-208V	443678	223-30-THSS-208V	4.8	16382	208	30° Symmetrical	63016209	25			
487498	223-30-TH-240V	443685	223-30-THSS-240V					240		63016249		
487504	223-30-TH-277V	443692	223-30-THSS-277V					277		63016279		
487511	223-30-TH-480V	481588	223-30-THSS-480V			480		63016489				
487528	223-60-TH-208V	443289	223-60-THSS-208V			208		63016209				
487535	223-60-TH-240V	443739	223-60-THSS-240V			240		63016249				
487542	223-60-TH-277V	443746	223-60-THSS-277V			277	63016279					
487559	223-60-TH-480V	481595	223-60-THSS-480V			480	63016489					
487566	223-90-TH-208V	443784	223-90-THSS-208V			208	63016209					
487573	223-90-TH-240V	443791	223-90-THSS-240V			240	63016249					
487580	223-90-TH-277V	443807	223-90-THSS-277V			277	63016279					
487597	223-90-TH-480V	481601	223-90-THSS-480V			480	63016489					
487603	343-30-TH-208V	481236	343-30-THSS-208V			7.5	25298	208		30° Symmetrical	63025209	33
487610	343-30-TH-240V	481243	343-30-THSS-240V								240	
487627	343-30-TH-480V	811439	343-30-THSS-480V	480	63025489							
487634	343-60-TH-208V	481267	343-60-THSS-208V	208	63025209							
487641	343-60-TH-240V	481274	343-60-THSS-240V	240	63025249							
487658	343-60-TH-480V	811637	343-60-THSS-480V	480	63025489							
487665	343-90-TH-208V	481298	343-90-THSS-208V	208	63025209							
487672	343-90-TH-240V	481304	343-90-THSS-240V	240	63025249							
487689	343-90-TH-480V	811835	343-90-THSS-480V	480	63025489							
487696	463-30-TH-480V	810531	463-30-THSS-480V	10.95	37372			480	30° Sym.	63036489	41	
487702	463-60-TH-480V	810739	463-60-THSS-480V			60° Sym.	63036489					
487719	463-90-TH-480V	810937	463-90-THSS-480V			90° Sym.	63036489					

## TH & THSS Series Product Accessories

UPC# 686334	MODEL	DESCRIPTION	FOR USE WITH	WT. (LBS.)
881128	VMB-41-SS	Wall Mounting Brackets (2)	All Mul-T-Mount Models	12
851152	CHWG-222	Stainless Steel Wire Guards	222 Series	2
851145	CHWG-342		342 Series	
851626	CHWG-462		462 Series	
854368	CHWG-223		223 Series	
854351	CHWG-343		343 Series	
854344	CHWG-463		463 Series	
Recessed Mounting Frames (UL)				
		Ceiling Cutout (in.)	Frame Size (in.)	
441995	RMF-222-SS-A	27 x 17-7/8	29-1/8 x 20	222 Series Stainless
449441	RMF-222-A	27 x 17-7/8	29-1/8 x 20	222 Series Painted
442077	RMF-342-SS-A	36 x 17-7/8	38-1/8 x 20	342 Series Stainless
441872	RMF-342-A	36 x 17-7/8	38-1/8 x 20	342 Series Painted
442107	RMF-462-SS-A	49 x 17-7/8	51-1/8 x 20	462 Series Stainless
449458	RMF-462-A	49 x 17-7/8	51-1/8 x 20	462 Series Painted
881104	RMF-223-SS	32 x 29-3/8	34-1/8 x 31-1/2	223 Series Stainless
881135	RMF-343-SS	41 x 29-3/8	43-1/8 x 31-1/2	343 Series Stainless
881111	RMF-463-SS	54 x 29-3/8	56-1/8 x 31-1/2	463 Series Stainless
487726	RMF-223	32 x 29-3/8	34-1/8 x 31-1/2	223 Series Painted
487733	RMF-343	41 x 29-3/8	43-1/8 x 31-1/2	343 Series Painted
487740	RMF-463	54 x 29-3/8	56-1/8 x 31-1/2	463 Series Painted
440783	31939009	Red Vycor Sleeves Reduces Quartz Lamp Brightness by 90%	All 1600W Qtz. Lamp	2
440738	31940009		All 2500W Qtz. Lamp	
440745	31941009		All 3650W Qtz. Lamp	
446150	632-1620	Red Quartz Lamps: 1.6kw. 208v	222,223 & RPH Series	2
446167	632-1624	Red Quartz Lamps: 1.6kw. 240v		
446228	632-2548	Red Quartz Lamps: 2.5kw. 480v		



# OCH Series Outdoor / Indoor Rated Quartz Electric Infrared Heater

## Features

Heats solid objects, not the air!



Manufactured in U.S.A.

- Frosted Quartz Tube heating element (included)
- Listed for suspended, totally exposed (outdoor) and indoor spot heating applications
- Finish: High-temp brown powder coated finish or corrosion resistant stainless steel 24 gauge housing
- 60° Symmetric Heat Pattern
- Gold anodized Aluminum reflector and end caps
- Painted models are direct wire, unless specified and are supplied with 6" lead wires for field connection in the internal wiring compartment. These models are available with a factory installed 6' cord set. The 208V model must have a field supplied plug.
- Stainless steel models include an electrical enclosure assembled to the end of the heater housing and (2) 6" long lead wires for direct field connection.
- Two 2' ft. long mounting chains and four S-Hooks included
- The OCH-Series can be surfaced mounted using the supplied mounting brackets which allow up to a 45° horizontal tilt adjustment.

## Product Models

FINISH - BROWN		FINISH - STAINLESS STEEL		CONNECTION TYPE	WATTS	BTU'S	VOLTS	AMPS	Qtz. Tube Repl. Element	WT. (LBS.)
Includes Electrical Enclosure										
UPC# 686334	MODEL	UPC# 686334	MODEL							
480444	OCH-46-120VE	480529	OCH-46-120V-SSE	Hard Wire	1500	5120	120	12.5	671-3784	10
480451	OCH-46-208VE	480536	OCH-46-208V-SSE		2000	6826	208	9.6	671-5061	
480468	OCH-46-240VE	480543	OCH-46-240V-SSE		2000	6826	240	8.3	671-3785	
480475	OCH-46-277VE	480550	OCH-46-277V-SSE		2000	6826	277	7.2	671-5018	
480499	OCH-57-208VE	480574	OCH-57-208V-SSE		12	3000	10239	208	14.4	671-5060
480482	OCH-57-240VE	480567	OCH-57-240V-SSE			3000	10239	240	12.5	671-3786
480505	OCH-57-277VE	480581	OCH-57-277V-SSE			3000	10239	277	10.8	671-5059
480512	OCH-57-480VE	480598	OCH-57-480V-SSE			2250	7679	480	4.7	671-5058
485975	OCH-46-120VCE	---	---	Corded	1500	5120	120	12.5	671-3784	11
485982	OCH-57-208VCE	---	---		2000	6826	208	9.6	671-5061	13
485999	OCH-57-240VCE	---	---		2000	6826	240	8.3	671-3785	

## Product Accessories

UPC# 686334	MODEL	DESCRIPTION	FOR USE WITH	WT. (LBS.)
480888	OCHWG-46	Stainless Steel Wire Guards	OCH-46 Series Models	2
480895	OCHWG-57		OCH-57 Series Models	2
881128	VMB-41-SS	Wall Mtg. Brackets (2)	ALL OCH Models	12
445948	VHC-15	Variable Heat Controller	208/240V OCH Models Only	3
485357	VHC-32	Variable Heat Controller	208/240V OCH Models Only	3

## OCH Sizing Chart

Mounting Height	Heater Model	Watts	Heat Pattern Coverage ( at floor level)			Total Watts / Sq. Ft.
			Length	Width	Sq. Ft.	
7'	OCH-46	1500	11	9	99	15.2
	OCH-46	2000	11	9	99	20.2
8'	OCH-46	1500	12	10	120	12.5
	OCH-46	2000	12	10	120	16.7
	OCH-57	3000	13	10	130	23.1
	OCH-57	2250	13	10	130	17.3
9'	OCH-46	1500	13	11	143	10.5
	OCH-46	2000	13	11	143	14.0
	OCH-57	3000	14	11	154	19.5
	OCH-57	2250	14	11	154	14.6
10'	OCH-57	3000	15	12	180	16.7
	OCH-57	2250	15	12	180	12.5
12'	OCH-57	3000	17	14	238	12.6
	OCH-57	2250	17	14	238	9.5

## Product Specifications

**Series:**  
OCH-46 & OCH-57

**Housing:**  
24 gauge Aluminized Steel with a baked on brown powder coat finish. Housing is cETLus Listed for indoor or outdoor applications. Horizontal mounting only.

**Reflectors and End Caps:**  
.040 Gold anodized Aluminum reflectors and end caps for superior reflectiveness. 60 degree medium (symmetric) pattern only.

**Elements:**  
Quartz Tubes. Frosted quartz envelope with a Nickel-Chromium coiled filament, porcelain end caps, and threaded-screw (stud) terminations. Fast heat-up and cool-down performance. Available Wattages from 1500 to 3000 Watts per element. Available voltages from 120 to 480 Volts.

**Controls:**  
OCH Series heaters are not manufactured with any control device on the unit. All controls are accessories and should be specified as such. Please consult the technical sales department of factory for help in determining applicable controls. Please follow installation instructions that accompany each heater.

**Accessories:**  
Adjustable mounting brackets (stainless steel only), vertical mounting brackets (stainless steel only), wire guards, thermostats, SCR controllers, and power contactor panels.

## Mounting Configurations & Reflector Pattern

- Mounting**
- Chain, surface mount or use our vertical mounting bracket as shown below. (Note:) All units must be mounted horizontally.
  - In-Built surface mounting bracket allows for fixture adjustment up to a 45° horizontal tilt.
  - As shown, the heater may be suspended at any horizontal angle desired.

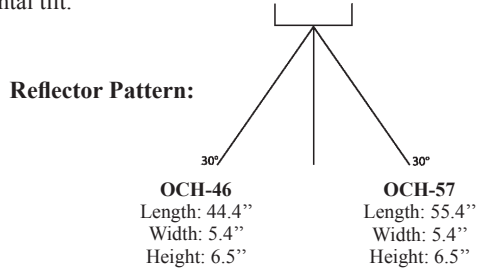
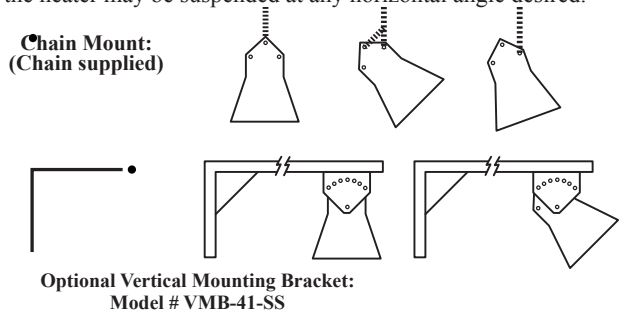

## Mounting Clearances & Recommended Mounting Height

Mounting Clearances	Recommended Mounting Height	
3" from ceiling; 12" from vertical surface 72" from face of heater to combustible surface 36" from another heater	OCH-46	7'-9'
	OCH-57	8'-10'

# RPH Series Outdoor Rated Stainless Steel Electric Infrared Heater



Mounting Plate (provided) on top center allows heater to be mounted parallel or angled using a standard pipe nipple and box cover (supplied by installer)

- Instant, high-intensity radiant heat, with 30° symmetric heat pattern.
- Listed for indoor spot heating and for outdoor unprotected applications.
- Specialized Ruby “Red” Quartz Lamp infrared heating element for glare reduction.
- Stainless Steel housing with Coilzak Aluminum reflector for good reflectivity & corrosion resistance.
- Heating element and mounting plate included.
- Dimensions: 24” x 5-3/8” x 4-1/2.”



Manufactured in U.S.A.

Mounting Clearances				Recommended Mounting Height	
6” from ceiling 24” from vertical surface 72” from face of heater to combustible surface				RPH-208	8’-12’
				RPH-240	8’-12’

UPC# 686334	MODEL	WATTS	BTU’S	VOLTS	PHASE	AMPS	REPLACEMENT QUARTZ LAMP	WT. (LBS.)	Optional Wireguard	
									UPC# 686334	MODEL
884501	RPH-208-A	1600	5,461	208	1	7.7	632-1620	5	880992	RPHWG
884518	RPH-240-A	1600	5,461	240	1	6.7	632-1624	5		

## MM Series “Mitey Midget” Electric Infrared Heater



Manufactured in U.S.A.

- Instant, high-intensity radiant heat, with 60° symmetric heat pattern.
- MM heaters excel as people-heaters in areas requiring a linear, compact & concentrated heat source.
- Listed for indoor industrial and commercial comfort heat applications.
- Heavy duty Aluminum extrusion with a bright Aluminum insert for maximum reflectivity.
- Anodized Aluminum housing, (0.62” thick).
- Heat Element Sold Separately.
- Dimensions: 3.750” Wide x 3.380” High.

Mounting Clearances
24” from ceiling & from vertical surface 24” from face of heater to combustible surface 36” from another heater

UPC 686334	MODEL	MAX WATTS	MAX BTU'S	VOLTS	PH	UNIT LENGTH	WT. (LBS.)	Optional Wireguards	
								UPC 686334	MODEL
444019	MM-13A	500	1707	120	1	13"	3	443906	MMWG-13
442763	MM-18A	750 / 1000	3413	208-240	1	18"	4	443913	MMWG-18
449540	MM-24A	900 / 1600	5461	208-277	1	24"	5	441896	MMWG-24
442725	MM-33A	2500	8533	480	1	33"	6	443920	MMWG-33
442039	MM-46A	3000 / 3800	12457	480-600	1	46"	7	442046	MMWG-46

All MM-13A through MM-46A models are ETL Listed for use with Quartz Lamps Only!

## FFH Series Electric Utility Infrared Heater

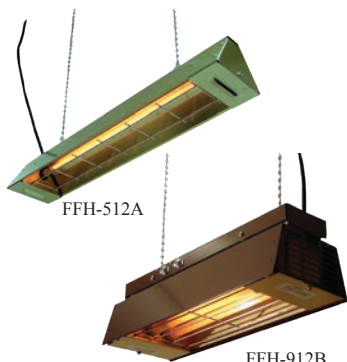

Manufactured in U.S.A.

- Both FFH Series Heaters are excellent for Farrowing & Finishing applications.
- Both units feature an 8 ft. 18/3 grounded cordset to plug into any 120V service.
- Gold anodized Aluminum reflectors, with a 90° symmetrical reflector pattern.
- Compact housing design, with the following housing finish:  
FFH-512A: Gold Anodized Finish  
FFH-912B: Brown Enamel Finish
- Quartz Tubes Heat Element(s), Wire Guard & (2) 4’ ft. Jack Chains are included.
- FFH-912B Only: Offers (2) On/Off toggle switches to operate heating elements independently.
- Listed for indoor industrial and commercial comfort heat

SIZING CHART - FFH SERIES					
MOUNTING HEIGHT	Heater Model	LENGTH	WIDTH	COVERAGE (Sq. Ft.)	WATTS / Sq. Ft.
6'	FFH-512A	7	6	42	13.1
	FFH-912B	6	7	42	21.4
7'	FFH-512A	8	7	56	9.8
	FFH-912B	7	8	56	16.1
8'	FFH-512A	9	8	72	7.6
	FFH-912B	8	9	72	12.5

UPC# 686334	MODEL	WATTS	BTU'S	VOLTS	PHASE	AMPS	REPLACEMENT QUARTZ TUBE	WT. (LBS.)	Dimensions (in.)			Mounting Clearances
									Length	Width	Height	
883894	FFH-512A	550	1877	120	1	5	671-3492	4	22	5	3	3” from ceiling 24” from vertical surface 72” from floor
882781	FFH-912B	450/900	3072	120	1	8	671-3454	4	17	6	4	

# Electric Infrared Heating Elements

## Clear & Red Quartz Lamps

Notes: Life expectancy of all heating elements - 5,000 hours (4yr. Pro-rated Warranty). All heating elements operate at 50 / 60 Hertz.

UPC 686334	Item #	Watts	Volts	Length (in.)		Fits Model	UPC 686334	Item #	Watts	Volts	Length (in.)		Fits Model
				Overall	Heated						Overall	Heated	
440059	630-05129	500	120	8-11/16	5	MM-13A	440363	631-25489	2500	480	28-11/16	25	342, 343 or MM-33A
442770	630-10209	1000	208	13-11/16	10	MM-18A	440684	631-25609	-----	-----	41-11/16	38	462, 463 or MM-46A
444118	630-10249		240				-----	-----					
440165	630-16209	1600	208	19-11/16	16	222, 223 or MM-24A	440677	630-36489	3650	480	RED QUARTZ LAMPS		
440172	630-16249		240										
440998	631-16249		240										
440189	630-16279		277										
481731	630-16489		480										
481748	630-25209	2500	208	28-11/16	25	342, 343 or MM-33A	446150	632-1620	1600	208	19-11/16	16	222/223
481755	630-25249		240				446167	632-1624	1600	240	19-11/16	16	or RPH
481762	630-25279		277				446228	632-2548	2500	480	28-11/16	25	342 or 343
440547	630-25489		480										

Model Suffix: 630 = Horizontal Burning "Clear"; 631 = Vertical OR Horizontal Burning "Clear"; = Horizontal Burning "Red"

- Color temperature emitted: approx. 4100° F (high brightness).
- Approximately 96% radiant efficiency.
- Excellent resistance to thermal shock.
- 3/8" Diameter clear or red quartz envelope.
- Coiled tungsten filament; sealed porcelain end caps; halogen gas filled.

## Quartz Tubes

Notes: Life expectancy of all heating elements - 5,000 hours. All heating elements operate at 50 / 60 Hertz.

UPC 686334	Item #	Watts	Volts	Length (in.)		Fits Model
				Overall	Heated	
443234	671-3784	1500	120	39-11/16	34-3/16	OCH-46
441810	671-5061	2000	208	39-11/16	34-3/16	
441803	671-3785	2000	240	39-11/16	34-3/16	
441933	671-5018	2000	277	39-11/16	34-3/16	OCH-57
441667	671-5060	3000	208	50-11/16	45-3/16	
441476	671-3786	3000	240	50-11/16	45-3/16	
441940	671-5059	3000	277	50-11/16	45-3/16	
441957	671-5058	2250	480	50-11/16	45-3/16	
440356	671-3454	450	120	12-15/16	8-7/16	FFH-912B
440080	671-3492*	550	120	19-1/2	16	FFH-512A
446242	671-5056	1000	120	18-5/16	14-7/16	CH-2212-1C
446259	671-5057	1425	240	27-5/16	23-7/16	CH-6424-1C

\*3/8" Diameter

- 5/8" Diameter frosted quartz envelope
- Nickel-Chromium alloy coiled element with porcelain end caps and pigtailed termination
- Color temperature emitted: approx. 1800° F (bright orange glow)
- Approximately 60% radiant efficiency
- Fast heat-up/cool-down
- Moisture resistance: High
- Mechanical ruggedness: Good

## Metal Sheath Elements

Notes: Life expectancy of all heating elements - 5,000 hours. All heating elements operate at 50 / 60 Hertz.

UPC# 686334	MODEL	WATTS	VOLTS	LENGTH (in)		Replacement Heating Element		
				Overall	Heated	Fits "CH-Models"	Fits "FHK Models"	
445870	641-37211	1800	120	23-1/16	18	CH-212-1A	FHK-212-1CA	
445832	641-35661	208	2000			240	CH-220-1A, CH-620-3A	FHK 2.0 & 6.0 KW Models
445795	641-35611	277					CH-224-1A, CH-624-3A	
445849	641-36051	480					CH-277-1A, CH-627-3A	
445801	641-35621	600					CH-248-1A, CH-648-3A	
445887	641-50011	600					CH-257-1A, CH-657-3A	
445856	641-36061	208	4500	44-7/16	39	CH-420-1A, CH-1320-3A, CH-2720-3B	FHK 4.5 & 13.5 KW Models	
445818	641-35631	240				CH-424-1A, CH-1324-3A, CH-2724-3B		
445863	641-36071	277				CH-427-1A, CH-1327-3A		
446174	641-35641	480				CH-448-1A, CH-1348-3A, CH-2748-3B		
445894	641-50021	600				CH-457-1A, CH-1357-3A, CH-2757-3B		

UPC# 686334	MODEL	WATTS	VOLTS	LENGTH (in)		Replacement Heating Element		
				Overall	Heated	Fits "CH-Models" Only		
445788	641-70321	1800	120	24-1/16	18	CH-212-1C		
445702	641-70241	208	2000			240	CH-220-1C, CH-620-3C	
445719	641-70251	277					CH-224-1C, CH-624-3C	
445726	641-70261	480					CH-227-1C, CH-627-3C	
445733	641-70271	600					CH-248-1C, CH-648-3C	
445771	641-70281	600					CH-257-1C, CH-657-3C	
445597	641-70001	208	4500	45-7/16	39	CH-420-1C, CH-1320-3B, CH-2720-3C		
445603	641-70011	240				CH-424-1C, CH-1324-3B, CH-2720-3C		
445610	641-70021	277				CH-427-1C, CH-1327-3B		
445627	641-70031	480				CH-448-1C, CH-1348-3B, CH-2748-3C		
445665	641-70041	600				CH-457-1C, CH-1357-3B, CH-2757-3C		

Note: Inner reflector shipped with replacement Metal Sheath Elements.

- 0.430" Diameter Incoloy metal sheath envelope
- Nickel-Chromium alloy coiled element imbedded in Magnesium Oxide insulating powder
- Color temperature emitted: approx. 1600° F (dull orange glow)
- Approximately 50% radiant efficiency
- Slowest heat-up/cool-down
- Moisture resistance: Lowest
- Mechanical ruggedness: Highest



## Variable Controllers



VHC-32

**Manufactured in U.S.A.**

- Solid State phase angle variable “Triac” knob controller adjusts heat settings from 10-100% with heat loads up to 15.4-Amps.
- 208/240 VAC single-phase, single stage controller, 3200 Watt max.
- Positive “Off” & built-in On/Off Rocker switch lights “red” during operation.
- NEMA 1 Aluminum enclosure with stainless steel face plate designed for wall mounting or suitable for semi-recessed applications.
- Must be mounted in a protected area.
- Can either operate Quartz Lamps or Quartz Tube Infrared Heaters.



VHC-15

**Manufactured in U.S.A.**

- Solid state variable device controls heat loads up to 15-Amps.
- 208/240 Volt “In-Line” Controller.
- Built in On/Off knob switch with positive “off” & surface plate included.
- Designed for a 2” x 4” electrical wall box mounting (not supplied).
- Must be mounted in a protected area.
- Can only operate Fostoria Quartz Tube Infrared Heaters.

30-Amp or 80-Amp Enclosed



18D-2-80CF ENC.

**Manufactured in U.S.A.**

- SCR Voltage Controller - 80 Amp MAX.
- Includes (1) 24-volt Potentiometer (3” square) to control the heat output.
- Only operates Quartz Lamps at 240 or 208-Volts, single phase only.
- Potentiometer can be mounted outside, but the SCR must be located in a protected area.
- Factory wired with millisecond fuses included.

UPC 686334	Model	Description	Dimension (In.)			Wt.
			Depth	Width	Height	
485357	VHC-32	Variable Heat Controller 208/240-Volt; 15.4 Amp	3	5	5	3 lbs.
445948	VHC-15	Variable Heat Controller; 208/240-Volt; 15 Amp	3	5	5	3 lbs.
445634	18D-2-30CF (Open)	SCR Controller - 26 Amp MAX; No Enclosure	6	6	9	11 lbs.
445641	18D-2-30CF (Enclosed)	SCR Controller - 26 Amp MAX; Enclosure Included	8	10	12	15 lbs.
445658	18D-2-80CF (Enclosed)	SCR Controller - 80 Amp MAX; Enclosure Included	8	12	14	29 lbs.

## Snow & Ice Detectors



CIT-1



APS-3C

**Manufactured in U.S.A.**

- Main control unit for Automatic Snow & Ice Control Systems.
- By sensing both temperature and moisture the system activates and melts any snow & ice accumulations until conditions subside.
- NEMA 3R Enclosure is UL Listed and houses timers and switching electronics to operate the system.
- Capability to monitor up to 6 sensors (CIT-1).
- Unit can be manually activated and can be controlled and monitored from an optional remote switch (Model RCU-).
- Positioned above ground to maximize the sensors capability.
- Detects falling or blowing of precipitation such as snow when the temperature is below 38° F.
- Most common sensor device.

UPC# 686334	Model	Description	Dimension (In.)			Wt.
			Depth	Width	Height	
319614	APS-3C	Snow / Ice Control Switch	6.56	11.5	9.25	8 lbs.
319761	CIT-1	General Purpose Snow Sensor	3.25	3.25	4.13	1 lb.

Note: Any snow & ice control system should be used with the correct sized control panel (with contactors & fusing) as supplied by factory or your electrical contractor. Also, the APS-3C requires a control device (RCU-1, CIT-1, SIT-6E) in order to operate properly.

## Contactors Enclosures



FEC-30-120

**Manufactured in U.S.A.**

- Economical load handling / switch device, ideal for use with other control equipment.
- NEMA 1 Enclosures.
- Load rating up to 600V Max., 3-Pole.
- Magnetic contactor.

UPC 686334	Model	Contactor Amps	Coil Voltage	Cabinet Size (In.)			Wt. (LBS.)
				Depth	Width	Height	
440851	FEC-30-120	30	120	5	6	10	5
440868	FEC-30-240		208/240				
440875	FEC-60-120	60	120				
440882	FEC-60-240		208/240				

Note: Installer to provide overload protection for all infrared heaters.

# Electric Infrared Heating Controls

## Pre-Wired Contactor Panels

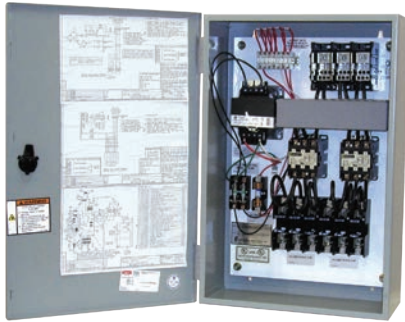

FPC2120



Manufactured in U.S.A.

- Factory pre-wired for quick installation, with the following optional equipment:  
 Snow & Ice Detector (APS-3C)  
 Single & Two-Stage Thermostats  
 Two-stage thermostats require a minimum 2-contactors.
- Step-down transformer and secondary fusing for 24V or 120V control circuit.
- 3-Phase load rated.
- Fuses are NOT included.
- NEMA 1 Enclosures.
- Max 50-Amp branch circuit fusing.

Note: Contact factory for 3R, 4, 4X, & NEMA 12 “special” built models.

### IMPORTANT FUSING INFORMATION

Fuses are NOT included since panels can be used with various infrared heat sources. Quartz Lamp Heat Sources: Use FRS-600V (or equal) “Time Delay” fuses; Class RK-5. Quartz Tube & metal Sheath Heat Sources: Use KTS-R 600V (or equal) “Fast Acting” fuses; Class RK-1. Fuse circuits as close to calculated load as possible. Circuits less than 35 Amps will require the use of fuse reducers.

## Standard Models

120-V CONTROL SYSTEM		24-V CONTROL SYSTEM		MAX AMPS	VOLTS	CABINET SIZE (IN.)			WT. (LBS.)
UPC# 686334	MODEL	UPC# 686334	MODEL			DEPTH	WIDTH	HEIGHT	
4459902	FPC8110	4864302	FPC8210	50	208	6.75	16	24	52
4460002	FPC2110	4864402	FPC2210		240				
4460102	FPC7110	4864502	FPC7210		277/480				
4460202	FPC4110	4864602	FPC4210		480				
4460302	FPC8120	4864702	FPC8220	100	208	6.75	16	24	70
4460402	FPC2120	4864802	FPC2220		240				
4460502	FPC7120	4864902	FPC7220		277/480				
4460602	FPC4120	4865002	FPC4220		480				
4460702	FPC8140	4865102	FPC8240	200	208	6.75	24	30	88
4460802	FPC2140	4865202	FPC2240		240				
4460902	FPC7140	4865302	FPC7240		277/480				
4461002	FPC4140	4865402	FPC4240		480				
4461102	FPC8160	4865502	FPC8260	300	208	6.75	30	36	106
4461202	FPC2160	4865602	FPC2260		240				
4461302	FPC7160	4865702	FPC7260		277/480				
4461402	FPC4160	4865802	FPC4260		480				

# FHK Series Portable Metal Sheath Electric Infrared Heater



2.0KW & 4.5KW  
Stand Models

6.0KW & 13.5KW  
Hand Cart Models

- Double side wall housings to reduce operating temperatures.
- 6.0 and 13.5KW heaters have double top baffles to reduce operating temperatures.
- 60° symmetrical heat pattern.
- Factory installed U-shaped metal sheath infrared heating elements have an average 5000 hour life.
- Heavy duty protective wire screens.
- GOLD anodized Aluminum internal reflector.
- Ground fault protection must be used.

### Square Feet Heated

KW	NON-PROTECTED AREA		SEMI-PROTECTED AREA		Required Clearance From Front of Heater
	BELOW 35 °F	ABOVE 35 °F	BELOW 35 °F	ABOVE 35 °F	
1.8 / 2.0	25	36	40	50	2 feet
4.5	64	75	90	125	3 feet
6	85	100	120	150	4 feet
13.5	192	225	270	375	7 feet

Manufactured in U.S.A.

### Standard FHK Models

UPC# 686334	MODEL	KW	BTU's	VOLTS	PH	AMPS	WT.
881739	FHK-224-1A	2.0	6,826	240	1	8.3	17 lbs.
881753	FHK-248-1A			480	1	4.2	
881784	FHK-424-1A	4.5	15,359	240	1	18.8	24 lbs.
881807	FHK-448-1A			480	1	9.4	
882910	FHK-624-3A	6.0	20,478	240	3	14.4	37 lbs.
					1	25.0	
882934	FHK-648-3A			480	3	7.5	
				480	1	13	
882965	FHK-1324-3A	13.5	46,076	240	3	33.0	65 lbs.
				480	3	17.0	
882989	FHK-1348-3A			480	1	29.0	

OPTIONAL 25' POWER CORD	
UPC# 686334	MODEL
880435	SO 16/3
880435	SO 16/3
880459	SO 12/3
880466	SO 14/3
880497	SO 14/4
880442	SO 10/3
880497	SO 14/4
880466	SO 14/3
880510	SO 8/4
316422	SO 12/4
880527	SO 8/3

Contact Factory for Special Build Models @ 208V, 277V or 600V.

### Factory Pre-Wired FHK Models With 15 Ft. Cord & Grounded Plug

UPC# 686334	MODEL	TYPE	KW	BTU's	VOLTS	PHASE	AMPS	WT.
881715	FHK-212-1CA	STAND	1.8	6,143	120	1	15.0	18 lbs.
882798	FHK-624-1CA	CART	6.0	20,478	240	1	25.0	40 lbs.

### FHK Infrared Control Options

UPC 686334	MODEL #	DESCRIPTION	Operating Voltage (VAC)	Dimensions (In)			WT. (lbs.)
				Ht.	Wd.	Dp.	
485814	TO-SK-1	Tip-Over Switch	208V - 600V	10.3	10.3	5.0	12
589376	DC-SK-1	Disconnect Switch	120V - 600V	5.0	6.0	4.0	5
486026	GF-SK-1	Ground Fault Sensing Switch	208V - 600V	10.3	10.3	5.0	12

Model "TO" & "GF" features include a positive "off" & a built-in on/off rocker switch that glows red during operation. Additionally, enclosure can mount directly to the terminal box on the back of the heater (FHK-6/13 only) or be mounted to a remote wall surface.



TO-SK-1 or GF-SK-1

Note: All SK-1 Models have NEMA-1 Enclosure, 50-Amp Max. & 1/3-Phase Rated.

# CH Series Portable Quarts Infrared Heater

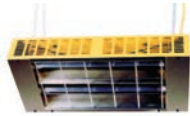

Chain mounted  
CH 2212-1C



Portable Cart Unit CH 6424-1C  
with FHK-1 Cart

**MODEL CH 2212-1C** has two 1000 Watt elements that can be switched on / off by toggle switches to produce 1000 Watts or 2000 Watts of heat. - 15' cord and NEMA 5-20 molded plug.

**MODEL CH 6424-1C** has two sets of 1425 Watt elements that can be switched on / off by toggle switches to produce 2850 Watts or 5700 Watts of heat. - 15' cord and NEMA L6-30 twist lock plug.

- 60° symmetrical heat pattern.
- Quartz tubes and built in wire guards included.
- Interior or protected outdoor use only.
- GOLD anodized Aluminum reflector and end caps.

UPC 686334	MODEL	KW	BTU's	VOLTS	PHASE	AMPS	WT.	
884099	CH-2212-1C	2.0 / 1.0	6826 / 3413	120	1	16.7 / 8.35	16 lbs.	
884105	CH-6424-1C	5.7 / 2.85	19454 / 9727	240	1	23.8 / 11.9	31 lbs.	
852401	FHK-1	OPTIONAL CART						20 lbs.



Note: CH-2212-1C operates with a 20- Amp molded plug.



Note: CH-6424-1C operates with a 30- Amp twist lock plug. **Manufactured in U.S.A.**



Listed for overhead operation

## PCH Series Portable Quartz Infrared Spot Heater

## Portable Infrared Instant On-Off Heat Gun



Width: 53"  
Height: 2-6"  
Depth: 28"



### Features

- Suitable for portable spot heat or for curing clear coat paint
- Height adjustable from 2' to 4'
- On-Off rocker switch standard
- 4 casters included; Tip-Over power cutoff safety switch
- 60° symmetrical heat pattern
- 5/8" diameter quartz tube included

- Average element life is 5000 hours
- Bright Aluminum reflector and end caps
- 20 gauge powder coated Steel housing
- 15' long, 3 wire (14/3) cordset with standard 3 pring NEMA 5-20P

UPC# 686334	MODEL	WATTS	BTU's	VOLTS	PHASE	WT.
884112	PCH-48C	1500	5120	120	1	30



### Features

- Provides instant spot heat in a controlled pattern
- Spot cure retouched paint and other finishes
- De-wrinkle or relax materials such as cloth-vinyl-leather
- T-3 Tungsten IR lamp
- Spring loaded power button switch

- 10' long, 18/3 grd. cordset with NEMA plug

UPC# 686334	MODEL	WATTS	VOLTS	AMPS	WT.
592284	RHG-1012A	1000	120	8.4	3
592277	RHG-1012B				

## Portable Electric Infrared Heat Panels

### Features

- Portable panels are built to withstand rigors of industrial and heavy-commercial applications, such as auto collision repair shops.
- 20 gauge Steel frame, base, and housing construction.
- 3" Steel casters for high stability and ease of mobility
- Gold anodized Aluminum reflectors and end caps allow 10% faster cure time than polished Aluminum reflectors, especially in paint and dust-laden atmospheres.
- Elements achieve full temperature in less than 2 minutes
- Fused disconnect switches are installed on the back of each unit.
- Units are positioned with adjustable hinges allowing the user to use direct heat more precisely to the target area.
- Gentle but effective medium-wave radiant heat can quickly boost, flash-off, or cure a variety of finishes, and lessens the chance of blistering and/or overheating the coating.
- Medium-wave infrared heating elements are also effective for flash-off of water-based clear coatings being mandated by environmental agencies in many states.

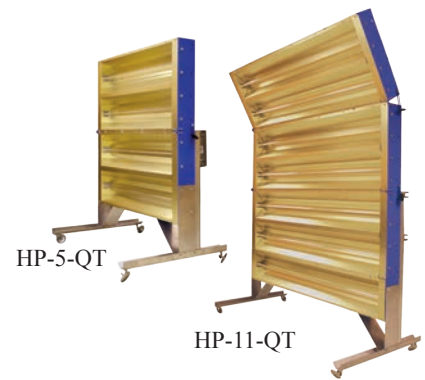

### General Curing Guidelines

Material Type	Solvent Based Primer	Water Based Primer	Two Component Primer	Water Based Clear Coat	Acrylic enamel & Polyurethane Clear Coat	Urethane Clear Coat & High Solids Top Coat
Curing Time	3-5 mins	3-6 mins	8-20 mins	3-10 mins	12-30 mins	10-30 mins

Note: Curing times will vary depending on material and shop conditions. This chart is based on distances of 18-24" away from the target area.

### Standard Models

UPC# 686334	Model	WATTS	VOLTS	AMPS	HEAT SOURCES	CABLE TYPE (20')	Dimension (In.)		Heated Area (In.)		Wt.
							Width	Height	Width	Height	
884129	HP-5-QT	4,800	240	20	4	12-3 SO	44-5/8	56-1/2	40	44	116
884136	HP-6-QT	6,400		26.7	4		66-5/8	89-1/2	61	77	141
884143	HP-11-QT	11,200		46.7	7						225



## FES Series Product Features & Information



Manufactured in U.S.A.



AVERAGE MINUTES TO ACHIEVE TEMPERATURE RISE*						
BUILDING SIZE:	1000 SQ. FEET		1500 SQ. FEET		2000 SQ. FEET	
HEATER:	TEMP RISE		TEMP RISE		TEMP RISE	
	20 °F	40 °F	20 °F	40 °F	20 °F	40 °F
10 KW	70 min	140 min	105 min	210 min	---	---
15 KW	47 min	94 min	71 min	142 min	94 min	188 min
30 KW	23 min	46 min	35 min	70 min	47 min	94 min
45 KW	10 min	30 min	20 min	35 min	35 min	40 min

\* Based on a 15' ceiling height - lower ceiling height will reduce time required

- Safety yellow heater enclosure with safety screens on both air intake and output openings.
- Optional 25' long SO type cord, ready for plug attachment is available for each model.
- Long-life finned tubular heating elements.
- Thermostat adjustment 40° to 100° F.
- Magnetic contactor.
- Automatic reset.
- High-limit thermal cutout switch.
- Fan only switch.
- 10" wheels.
- 800 CFM-15KW units - 1100 CFM-30KW units.

THE ELECTRIC  
ALTERNATIVE TO  
PROPANE AND  
KEROSENE SPACE  
HEATERS

### Standard FES Models

UPC#	MODEL	KW	BTU's	VOLTS	PH	AMPS	TEMP RISE	WT.
886017	FES-1520-3A	15	51195	208	3	42	45°F	65 lbs.
886079	FES-1524-1A	15	51195	240	1	63	45°F	69 lbs.
886024	FES-1524-3E	15	51195	240	3	36	45°F	65 lbs.
886031	FES-1548-3E	15	51195	480	3	18	45°F	65 lbs.
886048	FES-1560-3A	15	51195	600	3	15	45°F	65 lbs.
886055	FES-3048-3A	30	102390	480	3	36	90°F	83 lbs.
886062	FES-3060-3A	30	102390	600	3	29	45°F	65 lbs.

OPTIONAL 25' POWER CORD*	
UPC 686334	MODEL
316408	SO 6/4
880530	SO 4/3
316408	SO 6/4
316422	SO 12/4
316408	SO 6/4
316422	SO 12/4

10 KW, 240V, 1Phase factory pre-wired model with 10 ft. cable & straight blade range plug.

\*Plug not included.



UPC#	MODEL	KW	BTU's	VOLTS	PHASE	AMPS	TEMP RISE	WT.
874434	FES-0924-1C	9	30717	240	1	38	25°F	55 lbs.
886000	FES-1024-1CA	10	34130	240	1	42	30°F	60 lbs.

### 45 Kilowatt FES Model

OPTIONAL 25' POWER CORD	
UPC# 686334	MODEL
316439	SO 4/4
316408	SO 6/4

- Safety yellow heater enclosure with safety screens on both air intake and output openings.
- Optional 25' long SO type cord, ready for plug attachment is available for each model.
- Long-life finned tubular heating elements.
- Thermostat adjustment 40° to 100° F.
- Two 10" rear wheels and a front locking caster.
- High-limit thermal cutout switch with manual reset.
- 2200 CFM
- Fan only operation feature



UPC	MODEL	KW	BTU's	VOLTS	PH	AMPS	TEMP RISE	WT.
872225	FES-4548-3	45	153585	480	3	54.2	70°F	125 lbs.
487405	FES-4560-3	45	153585	600	3	44	70°F	125 lbs.



### Standard YES Models

- Wall / ceiling mount included with unit
- Unit is ready for direct wiring

Manufactured in U.S.A.



UPC	MODEL	KW	BTU's	VOLTS	PHASE	AMPS	TEMP RISE	WT.
886086	YES-1520-3A	15	51195	208	3	42	45°F	60 lbs.
886185	YES-1524-1A	15	51195	240	1	63	45°F	60 lbs.
886093	YES-1524-3E	15	51195	240	3	36	45°F	60 lbs.
886109	YES-1548-3E	15	51195	480	3	18	45°F	60 lbs.
886123	YES-3048-3A	30	102390	480	3	36	90°F	72 lbs.



Wall Mounted



Ceiling Mounted

# 198 Series 120 Volt Radiant and/or Fan Forced Portable Heater

- 3-Heat settings:
  - 600 Watt radiant
  - 900 Watt fan forced
  - 1500 Watt radiant & fan forced
- Temperature control thermostat
- Dual safety system:
  - Tip over switch
  - Manual reset type limit control
- 6' long - 3 conductor cord
- 1 year limited warranty

Width: 11"  
Height: 15"  
Depth: 12"



### Standard Models

UPC 686334	MODEL	WATTS	MAX BTU's	VOLTS	AMPS	PHASE	WT.
445092	198 TMC	1500 / 900 / 600	5120	120	12.5 / 7.5 / 5	1	9 lbs.

# 178 Series 120 Volt Ceramic Fan Forced Portable Heater



- Two heat settings: 1500W / 950W plus fan only setting (20W)
- Temperature control thermostat
- 6' long - 3 conductor cord
- Double safety system:
  - Automatic reset type limit control
  - Thermal cut-off device

Width: 11-1/4"  
Height: 10"  
Depth: 7"

### Standard Models

UPC 686334	MODEL	WATTS	MAX BTU's	VOLTS	AMPS	PHASE	WT.
445931	178 TMC	1500 / 950	5120	120	12.5 / 7.1	1	8 lbs.

Note: Photograph is a representation of stocked models. Actual model may vary in appearance.

# 188 Series 120 Volt "Milk-house" Style Fan Forced Portable Heater

- 1300W & 1500W heat settings plus fan only setting
- Temperature control thermostat
- 6' long - 3 conductor cord
- Triple safety system:
  - Tip over switch
  - Automatic reset type limit control
  - Thermal cut-off device

Width: 10"  
Height: 16"  
Depth: 9-1/2"



### Standard Models

UPC 686334	MODEL	WATTS	MAX BTU's	VOLTS	AMPS	PHASE	WT.
800419	188 TASA	1500 / 1300	5120	120	12.5 / 10.8	1	9 lbs.

# "Under-The-Desk" Confined Space Radiant Heat Panel



Manufactured in U.S.A.



- Use under desks for personal comfort or in small areas for freeze protection or moisture removal.
- Built in stand.
- Temperature control thermostat.
- 6' long - 3 conductor cord

Width: 22-3/4"  
Height: 8"  
Depth: 1-3/4"

### Standard Models

UPC# 686334	MODEL	WATTS	BTU's	VOLTS	PHASE	WT.
450881	170-TS	170	580	120	1	9 lbs.

# 483 Series 120 Volt Portable Baseboard Convection Heater

- 1500 Watt convection heater
- Temperature control thermostat
- Manual reset type limit control
- Power on indicator light
- 6' long - 3 conductor cord

Width: 48"  
Height: 5-1/4"  
Depth: 7-1/2"

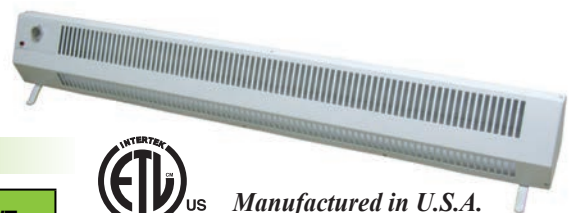

Manufactured in U.S.A.

### Standard Models

UPC 686334	MODEL	WATTS	MAX BTU's	VOLTS	AMPS	PHASE	WT.
870887	483 TM	1500	5120	120	12.5	1	13 lbs.

## 474 Series 240 Volt Dual Heat Fan Forced Portable Heater

80



- 2000W & 4000W heat settings
- Temperature control thermostat
- Manual reset type limit control
- 6' long - 3 conductor cord

Width: 16"  
Height: 16"  
Depth: 8-1/2"



20 AMP Plug  
NEMA #6-20P

UPC# 686334	MODEL	WATTS	MAX BTU's	VOLTS	AMPS	PHASE	WT.
446181	H474 TMC	2000 / 4000	13652	240	8.3 / 16.6	1	20 lbs.

## 5800 Series Garage/Workshop 240/208 Volt Fan Forced Portable Heater



- Up to 4800 Watts of heating comfort for garage or utility room applications
- 4000 Watts available for smaller areas.
- Built in bi-metal double pole thermostat - 50° to 90° range.
- Steel tubular heating element
- Wall/Ceiling bracket included
- Manual reset standard
- Power on and overheat pilot lights

ITEM	WIDTH	HEIGHT	DEPTH
Heater	10.625	11"	9.625"
Bracket	2.5"	10"	14.0"



UPC# 686334	MODEL	WATTS	MAX BTU's	VOLTS	AMPS	PHASE	PLUG TYPE	WT. (LBS)
503402	HF5840TC	4000/3000	13652	240 / 208	16.6 / 14.4	1	20 Amp	17
503396	HF5848TC	4800/3600	15086		20 / 17.3		30 Amp	

## ICH Series 240/208 Volt Construction Site/Utility Fan Forced Portable Heater

- Operates on 240V or 208V
- Steel tubular heating element
- 43°F air heat rise
- Internal overheat thermostat
- Temperature control thermostat
- 6' long cordset

Width: 10 5/8"  
Height: 12 3/4"  
Depth: 10"



20 AMP Plug  
NEMA #6-20P



UPC# 686334	MODEL	WATTS	MAX BTU's	VOLTS	AMPS	PHASE	WT.
450874	ICH-240C	4000 / 3000	13648	240 / 208	16.7 / 14.4	1	15 lbs.

## 680 Series "Bulldog" 240/208 Volt Fan Forced Portable Unit Heater



Swivel base allows unit to be wall, floor, or ceiling mounted.

- Operates on 240V or 208V
- Finned steel tubular heating element
- Internal manual reset thermal cut-out
- 6' long cord with molded plug
- Temperature control thermostat with 35°F to 85°F range
- 10' air throw - 262 CFM



20 AMP Plug  
NEMA #6-20P  
HF684TC



30 AMP Plug  
NEMA #6-30P  
HF685TC,  
HF686TC

Width: 13 1/2"  
Height: 17 1/2"  
Depth: 11 1/2"

UPC# 686334	MODEL	WATTS	MAX BTU's	VOLTS	PHASE	AMPS	TEMP RISE	WT.
446280	*HF684TC	4000/3000	13652/10239	240/208	1	16.7/14.5	48°F	20 lbs
446297	HF685TC	4800/3600	16384/12288	240/208	1	20.0/17.4	58°F	20 lbs.
446303	HF686TC	5600/4200	19107/14330	240/208	1	23.4/20.2	75°F	20 lbs.
683500	A1560	OPTIONAL WALL CEILING BRACKET FOR HF680 & ICH 240c SERIES HEATERS						

\* HF684TC UL listed only



# Specialty Heaters

## RPH Series Pump House Convection Specialty Heater



Manufactured in U.S.A.

- Provides protection against freezing for pump houses, utility rooms, relay stations, construction sheds, etc.
- Aluminum finned heating element
- Powder coated epoxy steel case
- Automatic temperature control thermostat with a 35°F to 65°F range.
- Dimension 20" x 5-1/2" x 4"

### Standard Models

UPC# 686334	MODEL	WATTS	BTU's	VOLTS	AMPS	WT.
999083	RPH1-5A	500	1706	120	4.2	5 lbs.
999090	RPH2-5A	500	1706	240	2.1	5 lbs.
International Models						
984263	RPH22-5Ai	500	1706	220	2.3	5
984270	RPH2-5Ai			240	2.1	

## FH Series In-Floor Fan Forced Specialty Heater



Manufactured in U.S.A.

- Powder coated 20 gauge steel case
- 14 gauge grill
- Steel spiral finned heating element
- Auto reset thermal cut out with audible alarm.
- Floor opening: 14-1/8" x 7-1/4" x 7-3/8"
- Grill dimensions: 15-13/16" x 8-13/16"

### Standard Models

UPC# 686334	MODEL	WATTS	BTU's	VOLTS	AMPS	WT.
378239	FH15	750	2560	120	6.25	15 lbs
		1500	5120	120	12.5	
		1500/1125	5120 / 3840	240/208	6.25/5.41	
OPTIONAL FIELD INSTALLED THERMOSTATS						
378277	FH1T	Single Pole Integral Thermostat Kit				1lb

## TSH Series Fan Forced Kickspace Specialty Heater



Manufactured in U.S.A.

- Fits into soffits, stair risers or under utility cabinets
- Finned steel heating element.
- Manual reset thermal cut-out
- Recessed opening: 22-3/8" x 3-5/8" x 11-1/2"
- Grill dimensions: 23-7/8 x 3-5/16

### Standard Models

UPC# 686334	MODEL	WATTS	BTU's	VOLTS	AMPS	WT.
381802	TSH20J	1500 / 1000	5120 / 3412	120	12.5 / 8.4	16 lbs
		1500 / 750	5120 / 2560	208	7.2 / 3.6	
		2000 / 1000	6284 / 3412	240	8.4 / 4.2	
970174	TSH20JW	Above Model with White Grill				
OPTIONAL FIELD INSTALLED THERMOSTATS						
378376	TSH1TX	Single Pole Integral Thermostat Kit				1lb
378383	TSH2TX	Double Pole Integral Thermostat Kit				1lb



# CF & CFH Series Variable Speed Air Curtains

## Product Specifications

**CABINET:** Shall be constructed of 20 gauge rigid steel with baked on epoxy powder coat paint for durability.  
**DISCHARGE VANES:** Shall extend the entire width of the unit and be adjustable for optimum performance of air flow.  
**BLOWERS:** Shall be forward curved centrifugal type, DWDI with corrosion resistance scroll and wheel.  
**MOTORS:** Shall be heavy duty, PSC, direct drive high efficiency and designed for use with SCR controllers. Motors shall be permanently lubricated for long life and have thermal over load protection. Motor shall have double insulation protection for quieter operation. Quick disconnects shall be supplied to accommodate easy installation and service of motor.



Manufactured in U.S.A.



SCR SPEED CONTROLLER: Supplied on all units compatible with the motor with low end adjustment for air volume control and savings in power consumption.  
**ELECTRIC HEAT (OPTIONAL):** Electric heater available as field installed option. Electric heater shall be steel sheath element with helical wound steel fins for maximum heat transfer and safety.

UPC 686334	SIZE (in)	MODEL	FT. / MIN. HI - LOW	NOZZLE CFM	VOLTS	RPM HI - LOW	AMPS HI - LOW	WATTS HI - LOW	WT. (lbs)	
<b>STANDARD UNITS: 1/2 HP MODELS - UP TO 10' HIGH DOORWAYS - WITHOUT HEAT SECTION</b>										
671200	36	CF36	3288/455	2672/333	120	1659/620	3.9/3.4	472/154	74	
671217	48	CF48	4168/786	4515/766		1606/583	4.4/3.6	519/189	82	
671224	60	CF60	4168/764	6544/931		1636/562	4.4/3.8	509/199	90	
	72	2 EA: CF36	3288/455	5344/666		1659/620	7.8/6.8	944/308	148	
	96	2 EA: CF48	4168/786	9030/1532		1606/583	8.8/7.2	1038/378	164	
	108	3 EA: CF36	3288/455	8016/999		1659/620	11.7/10.2	1416/462	222	
	120	1 EA: CF48	4168/786	9859/1432		1606/583	12.2/10.4	1982/497	230	
		2 EA: CF36	2672/333							
<b>HEAVY DUTY UNITS: 3/4 HP MODELS - UP TO 12' HIGH DOORWAYS - WITHOUT HEAT SECTION</b>										
671231	36	CFHD36	3288/1120	2672/819		120	1689/603	4.4/4.3	603/192	77
671248	48	CFHD48	4256/929	4611/906	1662/500		5.9/4.8	586/168	85	
671255	60	CFHD60	4256/924	5763/1126	1652/509		5.2/4.4	708/172	93	
	72	2 EA: CFHD36	3288/1120	5344/1638	1689/603		8.8/8.6	1206/384	154	
	96	2 EA: CFHD48	4256/929	9222/1812	1662/500		11.8/9.6	1172/336	170	
	108	3 EA: CFHD36	3288/1120	8016/2457	1689/603		13.2/12.9	1809/576	231	
	120	1 EA: CFHD48	4256/929	9955/2544	1662/500		14.7/13.4	2981/552	239	
		2 EA: CFHD36	3288/1120							

EXAMPLE					Use the example shown (left) to order unit with heat section by specification
Model #	Unit Width	KW	Volts	Phase	
CFHTR	36	10.0	208	3	



**Air Curtain with Heater Module**

NOTE: All heating sections are constructed of totally enclosed fin tubular elements for safety and longer operating life. With heating section installed, unit becomes a 24 Volt control unit and can utilize a low voltage thermostat for control of heating.

NOTE: For 72" through 120" units, order multiple heater modules corresponding to the actual air curtain models

MODEL	HEATER WIDTH	KW	VOLTS	PHASE	HEATER AMPS	MINIMUM CIRCUIT AMPS	MAXIMUM FUSE AMPS	BTUH	75°C WIRE AWG	
CFHTR	36, 48, or 60 Inch Width NOTE: 12KW MAXIMUM ON 36" WIDTH UNITS	3	208	3	8.3	10.4	15	10,239	14	
					7.2	9.0	15		14	
			480	1	3.6	4.5	15		14	
					10.8	13.5	15		14	
			208	1	14.4	18.0	20		12	
					12.5	15.6	20		12	
		5	208	3	13.8	17.25	20	12	17,075	12
					12.0	15.0	20	12		
			480	1	6.0	7.5	15	14		
					18.0	22.5	25	10		
			208	1	24.0	30.0	35	8		
					20.8	26.6	30	10		
		7.5	208	3	20.8	26.0	30	10	25,597	10
					18.0	22.5	25	10		
			480	1	9.0	11.3	15	14		
					27.0	33.8	40	8		
			208	1	36.0	45.0	50	6		
					31.2	39.0	45	8		
		10	208	3	27.7	34.4	40	8	34,130	8
					24.0	30.1	35	8		
			480	1	12.0	15.0	20	12		
					36.1	45.1	50	6		
			208	1	41.6	52.0	60	6		
					41.6	52.0	60	6		
12	208	3	33.3	41.6	45	8	40,956	8		
			28.8	36.0	40	8				
	480	1	14.4	18.0	20	12				
			43.3	54.1	60	6				
	208	3	41.6	52.0	60	6				
			36.0	36.0	55	6				
480	3	18.0	18.0	30	10					

## SD Series - Setback on Demand Thermostat

**FULLY AUTOMATIC:** All the savings without any of the hassles of a programmable thermostat. Once installed, everything is automatic. When people are present it automatically controls to the comfort setting. When they leave, it automatically returns to the economy setting.

**SMART COMFORT:** The SD thermostat learns your schedule so you arrive to a comfortable temperature. Holidays are no problem. When no-one arrives, it automatically returns to the economy setting.

**AUTO-CHANGEVER:** Our Auto-Changeover doesn't limit your comfort settings. We incorporate an adjustable deadband to protect your equipment while maintaining comfort. Factory set at 1 degree, but adjustable from 1-5 degrees.

**ONE MODEL WORKS WITH ALMOST ANY LOW VOLTAGE SYSTEM.:** The SD thermostat works with low voltage systems up to 4 stages of heat, 4 stages of cool, or any combination up to a total of 4 stages including Heat Pumps.



Patent Pending

UPC#	MODEL	COLOR	TYPE
686334			
523646	SDHW1001	White	Hardwire

## ET Series - Line Voltage



### Features

- Single pole and double pole
- Heat only, cool only, & heat or cool
- DP models include positive off
- Celsius and Fahrenheit temperature scale
- Optional Thermometer
- 22 Amps, 277 Volts AC

UPC # 686334	MODEL	DESCRIPTION
538725	AET5DWS	Double Pole 22 Amp, 120-277V with leads, Anticipator
538732	AET5SWS	Single Pole 22 Amp, 120-277V with leads, Anticipator
538886	ET5DS	Double Pole 22 Amp, 120-277V, Heat Only
538749	ET5D4S	Double Pole 22 Amp, 120-277V, 35-75°F Temp Range
538756	ET5DTS	Double Pole 22 Amp, 120-277V, with Thermometer, Heat Only
538763	ET5DWS	Double Pole 22 Amp, 120-277V, Heat Only with Leads
538770	ET5MS	Heat Only, 2 Stage
538787	ET5SS	Single Pole 22 Amp, 120-277V, Heat Only
538794	ET5S4S	Single Pole 22 Amp, 120-277V, 35-75°F Temp Range
538800	ET5SRS	Single Pole 22 Amp, Cooling Only
538893	ET5SRTS	Single Pole Cool with Thermometer
538817	ET5STS	Single Pole 22 Amp, Heat Only with Thermometer
538824	ET5SWS	Single Pole 22 Amp, Heat Only with Leads
538831	ETD5MS	Double Throw, 2 Stage Heat, 1 Stage Cool
538848	ETD5MTS	2 Heat, 1 Cool with Thermometer
538855	ETD5SS	Single Pole Double Throw Heat/Cool
538862	ETD5STS	Single Pole Double Throw Heat/Cool with Thermometer

## EPET Series and HLT Series Hazardous Location



### Features

- SPDT & DPDT Models
- Heat or cool compatible
- Celsius and Fahrenheit temperature scale
- Bi-Metal or capillary sensor
- Snap action switch
- Casting tapered top and bottom for 3/4" conduit
- 1/2" thick cast Aluminum housing
- Dimension 5-3/4" x 6-3/8" x 5.57"

Motor Rating (full load): 3/4 HP @ 125V, 1-1/2 HP @250V  
 Pilot Duty Rating 125VA @ 24VAC  
 NEMA Class Seven Div. 1 Approved  
 Class I Group C & D, Class II Group E, F, & G  
 Not rated for Group B

UPC# 686334	MODEL	DESCRIPTION	LOAD RATINGS	RANGE
538077	EPETD8D	DPDT - Bi-Metal	22A @120-277VAC	50-90°F
538107	EPETD8S	SPDT - Bi-Metal	22A @120-277VAC	50-90°F
528078	EPETP8D	DPDT - Bi-Metal	22A @120-480VAC	50-90°F
528061	EPETP8S	SPDT - Bi-Metal	22A @120-480VAC	50-90°F
523158	HLT-1	SPDT - Capillary	22A @120-277VAC	40-110°F
523165	HLT-2	DPDT - Capillary	22A @120-277VAC	40-110°F
Master ctn: 4 pcs, 24 lbs (varies slightly by model), 16" x 14.5" x 6"				
EPET Series incorporate plastic knob & Bi-Metal Sensor housing.				
HLT Series incorporates screwdriver temperature adjustment slot and all metal housing. External bulb and capillary sensor.				

## 2000 Series - Line Voltage



### Features

- White or Ivory
- Single pole and double pole
- Heat Only
- DP models include positive off
- 22 Amps, 277 Volts AC

UPC# 686334	MODEL	COLOR	DESCRIPTION
502849	S2022H10AA	White	Single Pole with leads, 22 Amp
502436	S2022H10AB	Ivory	
502856	D2022H10BA	White	Double pole with leads, 22 Amp
502443	D2022H10BB	Ivory	
502917	S2025H10AA	White	Single Pole with leads, 25 Amp
502924	D2025H10BA	White	Double pole with leads, 25 Amp

## TW Series



### Features

- Single and double pole models
- Wire leads
- Tamper resistant

### Load Rating

- 22 Amps resistive @ 120 VAC
- 18 Amps resistive @ 277 VAC

UPC# 686334	MODEL	DESCRIPTION	TEMPERATURE SCALE
502009	TW145	SP, Beige with Leads	Tamper Resistant
502016	TW146	DP, Beige with Leads	Tamper Resistant
Master Carton: 25 Pcs, 12 lbs. (varies slightly by model), 16" x 14" x 5.5"			

## Washdown Series



### Features

- Single and double pole models
- Rain tight NEMA 4X rating
- Stainless steel hardware
- Coil capillary temperature sensor

UPC# 686334	MODEL	DESCRIPTION	TEMPERATURE SCALE
523424	TW155A	SP, Rain tight	40-110°F
523431	TW255A	DP, Rain tight	40-110°F
22 Amps @ 120/250/277 VAC, 5" x 5" x 3" Case			

## Industrial Series



### Features

- Coil capillary (CKT) models
- Bi-Metal models (KT)
- Rugged steel case
- SPST & SDPT models
- Hard wired models rated for 22A resistive @125-250 VAC
- Coded models rated for 13A resistive @125VAC

UPC# 686334	MODEL	DESCRIPTION	RANGE	CONNECTIONS	SCALE
534048	CKTD110	SPDT Heat or Cool	40 - 110°F	Wire Leads	F
534086	KT110	SPST Heat Only	-10 - 100°F	Wire Leads	C & F
534109	KT121	SPST Heat Only	-10 - 100°F	6' Cord/Plug	C & F
534178	KTD110	SPDT Heat or Cool	-10 - 100°F	Wire Leads	C & F
534369	KTO110	SPST Cool Only	-10 - 100°F	Wire Leads	C & F
534215	KTO121	SPST Cool Only	-10 - 100°F	6' Cord/Plug	C & F
Master Carton: 13.75" x 14" x 9", Qty 9-12, 14lbs.-16lbs. depending on model					

## L Series



### Features

- 6' or 8' Capillary
- Rugged steel cage
- SPDT for Heat or Cool
- 25A resistive
- Rated differential of 6°F

UPC# 686334	MODEL	DESCRIPTION	RANGE	CAPILLARY	SCALE
534260	L06Y-01	SPDT Heat or Cool	0 - 90°F	6'	F
534277	L08Y-01	SPDT Heat or Cool	0 - 90°F	8'	F
Master Carton: 13.75" x 14" x 9", 12 Pcs, 18lbs.					

## Electromechanical Humidistat



### Features

- 4.4 amp @ 120VAC
- 2.2 amp @ 240VAC
- 50VA @ 24VAC - 240VAC
- 10% - 60% relative humidity range

### Standard Models

UPC#	MODEL	DESCRIPTION
686334		
523370	H46D1214	Humidistat/Electromechanical

## Electromechanical De-Humidistat



### Features

- 4.4 amp @ 120VAC
- 2.2 amp @ 240VAC
- 50VA @ 24VAC - 240VAC
- 10% - 60% relative humidity range

### Standard Models

UPC#	MODEL	DESCRIPTION
686334		
589147	H1D1AA	Dehumidistat/Electromechanical

## Honeywell Line Voltage Thermostats



T4398A 1021  
Precision Mechanical



### Features

- Heat only thermostats
- Accurate temperature control
- 22 Amp resistive for mechanical models

### Standard Models

UPC#	MODEL	VOLTAGE	DIMENSIONS	DESCRIPTION
686334				
503303	T4398A 1021	120-240	2.875"x4.375"x2.00D	Precision Electric Heating. SPST, 50-80 °F, 22 Amp @ 120-240V 19 Amp @ 277V



TL8230A 1003  
Electronic Programmable



### Features

- Heat only thermostats
- Accurate temperature control
- 16 Amp resistive for electronic models
- Energy Star compliant.

### Standard Models

UPC#	MODEL	VOLTAGE	DIMENSIONS	DESCRIPTION
686334				
503365	TL8230A 1003	240/208	2.70"x4.90"x.90D	Electronic Programmable Line Voltage DPST, 15 Amp, 40-86 °F

## Wireless RF Interface Series



RFT-1 shown with  
UT thermostat

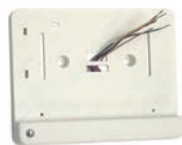

RFT-1



RFR-5

### Features

- Heat only, Cool only
- 4 wire Heat/Cool
- Standard 2 stage Heat/ 1 Stage Cool Heat Pumps
- Multistage heating and/or cooling equipment
- Works with most low voltage thermostats
- Temp Range: 50-130 F
- Max Operating Range: 50 Feet

UPC#	MODEL	DESCRIPTION	VOLTAGE	CONNECTIONS
686334				
523554	RFT-1	RF Thermostat Transmitter Dim: 4" x 5" x .875"	2-AAA Batteries	6 Wires
523561	RFR-5	RF Relay Interface Dim: 4.5" x 6" x 1.25"	24 VAC	R-C-R1 1-2-3-4-5
523578	RKit-5	RFT-1 & RFR-5 Package	2 AAA 24 VAC	R-C-R1 1-2-3-4-5



# Thermostats & Controls

## Low Voltage Programmable Thermostats



TH115-A-024T

### Features

- 7 Day, 4 Settings Per Day
- Control Accuracy +/- 1°F of Setpoint Temp
- Pre-Programmed or Custom Settings
- Backlit Display, Energy Star Compliant

### Standard Models

UPC#	MODEL	DESCRIPTION
686334		
523400	TH115-A-024T	Heat Only Temp Range:40-86°F Dims:4.89"H x 2.79"W x .91"D

### Features

- 7 Day, 4 Settings Per Day
- Control Accuracy +/- 1°F of Setpoint Temp
- Pre-Programmed or Custom Settings
- Backlit Display, Energy Star Compliant

### Standard Models



TH147-P

UPC#	MODEL	DESCRIPTION
686334		
523585	TH147-P	7 Day, 4 Settings per Day, Heating/Cooling, 1 Stage Heat/Cool Temp Range Heat:41-82°F, Cool:59-95°F Dims: 5"W x 3"H x 1"D,

## 2 Stage Low Voltage Thermostat

### Features

- 24V single or 2 stage heat and cool
- Gas, oil, or electric with air conditioning.
- Heat only, Heat only with fan, Cool only.
- Battery only, common wire only or common wire with battery backup.
- System settings - Heat, Off, Cool, Auto, Emergency Heat.
- Temperature range - Heat 40-90°F, Cool 50-99°F.
- Dimensions: 3-9/16" H x 5-13/16" W x 1-1/2" D

### Standard Models



TW123

UPC#	MODEL	VOLTAGE	TEMP RANGE	MAX AMP
686334				
691116	TW123 / TH5220D	750MV - 2DV	40-90 Heat 50-99 Cool	1.0

## Round - Low Voltage

### Features

- Heat only for 24V heating systems
- Does not contain Mercury
- White color
- Temperature range - 50° - 90°F
- Dimensions 3-11/16" diameter

### Standard Models



UPC#	MODEL	DESCRIPTION	VOLTAGE	MAX AMP
686334				
260008	A6176	Heat/Cool	24 VAC	1.0

## UT Series - Low Voltage



### Features

- Vertical or horizontal mounting
- Long life sealed contacts
- Does not contain Mercury
- Leveling not required
- Fahrenheit and Celsius temperature scales
- 2-3°F rated differential
- Anticipator (except UT9001)

### Standard Models

UPC# 686334	MODEL	DESCRIPTION	VOLTAGE	TERMINALS	SWITCHES
523059	UT1001	Heat Only	24VAC or MV	R & W	None
523066	UT3001	Cool Only	24 VAC	R, Y & G	Cool/Off Fan/Auto
523134	UT6001	Deadband	24 VAC	R, W & Y	None
523073	UT8001	Heat/Cool	24 VAC	RC, RH, W, Y, & G	Heat/Off/Cool Fan/Auto
523110	UT9001	Heat Only	Millivolt	R & W	None

Master Carton: 50 pcs, 17 lbs, 19" x 11.5" x 9"

## RK Series - Low Voltage



### Features

- Heat only models
- Positive off
- Does not contain Mercury
- Leveling not required
- Long life sealed contacts
- Fahrenheit and Celsius temperature scales
- 2-3°F rated differential

### Standard Models

UPC # 686334	MODEL	DESCRIPTION	VOLTAGE	RANGE	ANTICIPATOR
526012	RK120EAA	Heat Only	24VAC or MV	50°-90°F	Yes
526203	RK124EAA	Heat Only	24VAC or MV	35°-75°F	Yes
526050	RK130EAA	Heat Only	Millivolt	50°-90°F	No
526326	RK134EAA	Heat Only	Millivolt	35°-75°F	No
526142	RKWP1AA	Wall Plate	NA	NA	NA

Master Carton: 100 Pcs, 24 lbs, 16.5" x 15" x 8"

## Low Voltage Relays



Two switch unit shown.

### Features

- Snap action switch
- 1/2" male conduit spud
- 45 second average time delay
- Temperature range - 50° - 90°F
- Built-In transformer

### Standard Models

UPC# 686334	MODEL	PRIMARY VOLTAGE	DESCRIPTION
260039	24A05A-1	120 Volts	Single Switch, single throw with In-Built Transformer for remote mounting or in a factory provided optional enclosure
260046	24A05E-1	208 Volts	
260053	24A01G-3	240 Volts	
260107	24A06G-1	240 Volts	Two switch, single throw with In-Built Transformer, 25 Amps per switch

## TG Series Thermostat Guards



### Standard Models

UPC# 686334	MODEL	DESCRIPTION
589123	TG1	Plastic Stat Guard/ 6.25" x 3.625" x 3.25" Opening
589109	TG1B	Metal Stat Guard/ 5.25" x 4.625" x 3" Opening
589130	TG2	Plastic Stat Guard/ 5.25" x 4.625" x 3.25" Opening
589161	TG2B	Metal Stat Guard/ 6.25" x 3.625" x 3.25" Opening
589116	TG3	Plastic Stat Guard/ 8.125" x 4.625" x 3.625" Opening
589178	TG3B	Metal Stat Guard/ 6.75" x 4.50" x 3.50" Opening
523615	TG4	Plastic Stat Guard / 3.50" x 3.937" x 1.75" Opening
523622	TG5	Plastic Stat Guard / 5" x 3.31" x 1.75" Opening
523639	TG6	Plastic Stat Guard / 5.75" x 4.625" x 1.75" Opening

### Features

- 8 tumbler locks



Sizing formula for TAT Series heaters: 50 Watts of heat per square foot of heated space or 50W/sq ft.

Example: An 800 square foot structure will require 40,000 Watts of heat to obtain 150 degrees of prolonged heat to be effective. (800 sq ft x 50 Watts per square foot = 40,000 Watts of heat or 40KW of heat)

## Product Features

- Heavy duty industrial construction
- Forward curved centrifugal blower
- High Temperature ball bearing motor
- Optional replaceable filter
- Single point power connection
- 24 volt control
- Heavy duty spiral finned elements constructed of stainless steel
- Safety devices include airflow switch, automatic limit control and manual reset limit control for secondary protection
- Disconnect switch and Unit Mounted Thermostat with range of up to 120 to 150 °F
- The "TAT" series is sold as a system that includes the base unit, three supplemental units and the remote timer/ temperature control (supplemental units may be purchased separately if necessary)

## Product Specifications

### APPLICATIONS:

- The "TAT" series is designed to heat small and mid-sized rooms up to 150 °F. This provides effective portable heating to areas infected with insects. It kills adult insects and will dehydrate larvae and eggs, making them unable to hatch. Although chemical sprays only target adult insects, they can be used before utilizing the "TAT" system in order to kill the adult insects.
- The system is designed to bring the temperature up to 150 °F in one hour or less, if all preliminary requirements are met.
- The "TAT" system may be used for water remediation, as well, in combination with adequate ventilation. Specific models for water remediation are also available.

### TAT BASE UNIT:

- Heavy duty stainless steel spiral fin heating elements
- High temperature, ball bearing 1/3 HP - 1075 RPM blower motor
- Forward curved centrifugal blower-900 CFM of air output
- Safety devices include airflow switch, disconnect switch, automatic limit control and manual reset limit control for secondary protection
- 50 Amp unit may be linked to a 30 Amp unit to provide heating for larger spaces.
- Timer/Temp controller may be used to control both units but must use the 50 Amp base unit as the master.

### SUPPLEMENTAL TAT CONVECTORS

- 3 convectors are an integral part of each TAT system
- 120 Volt, 15 Amp (Standard wall plug) - 5120 BTU size
- Supplied with 25' prewired cable that connects them to the TAT base unit control section with a three pin connector
- If used in front of windows or large glass doors, they will reduce heat loss and provide more even heating

### TIMER/TEMPERATURE CONTROL UNIT

- Timer/Temp Controller is an integral part of the TAT system
- 24 Volt control device that controls the heat output of the TAT base unit and up to three TAT convectors for an operating range of 120 - 150 °F and for a time period of 1 -10 hours after the preset temperature is reached
- Supplied with a 25' prewired cable that connects to the TAT base unit control section using a four pin connector
- Mounts on Door outside the area being treated.
- LED lights will indicate when treatment is complete

# Thermal Area Treatment Heaters

## Standard Models

UPC# 686334	STYLE MODEL NUMBER	BASE UNIT KW	BASEBOARD PERIMETER HEATER KW	TOTAL SYSTEM KW	BASE UNIT VOLTS	BASEBOARD PERIMETER HEATER VOLTS	PHASE	BASE UNIT AMP	BASEBOARD PERIMETER AMP-EACH CIRCUIT (3)	PLUG TYPE	
										BASE UNIT	PERIMETER
397568	TAT5-240-1/3BB/1T	5.3	1.5 (X3)	9.8	240	120	1	24	12.5	Nema 10-30	Nema 5-15
397629	TAT5-208-1/3BB/1T*	5.3	1.5 (x3)	9.8	208	120	1	27	12.5	----	Nema 5-15
397551	TAT8-240-1/3BB/1T	8.4	1.5 (X3)	12.9	240	120	1	37	12.5	Nema 14-50	Nema 5-15
397612	TAT8-208-1/3BB/1T*	8.4	1.5 (x3)	12.9	208	120	1	42	12.5	----	Nema 5-15
397520	TAT20-480-3/3BB/1T	20	1.5 (X3)	24.5	480	120	3	26	12.5	Nema L16-30	Nema 5-15
397582	TAT-ILC-25	25' Shielded Cable									

\*208 Volt models do not have a cord supplied

## Accessories

UPC# 686334	MODEL	DESCRIPTION	HP	CFM / RPM	MAX AMPS	VOLTS	WT (LBS)
397636	TAT-24-FAN-120V-1	Thermal Area Treatment Floor Fan	1/3	5000/1160	3.1	120	30

UPC# 686334	MODEL	DESCRIPTION	KW	BTU	VOLTS	PHASE	AMPS	TEMP RISE	WT (LBS)
397834	TAT-30	30KW Salamander	30	102390	480	3	36	43	115
397841	TAT-45	45KW Salamander	45	153585	480	3	54.2	70	125

## Product Dimensions

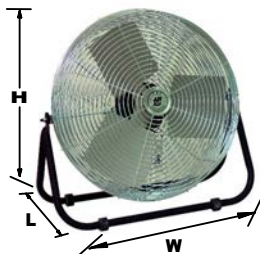
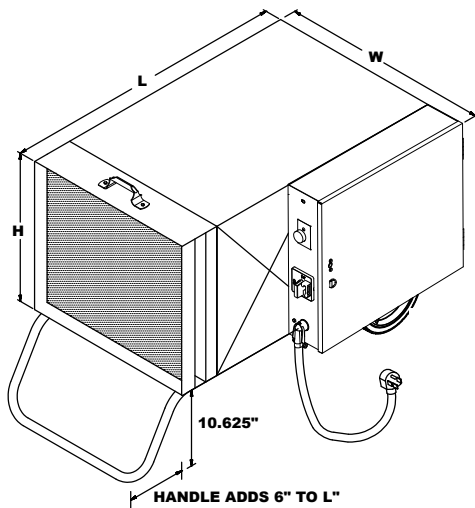

**TAT-24-FAN-120V-1**

- Single speed
- Head tilts 360°
- Coated steel guards
- SJT type 3 conductor
- Steel hub / Aluminum blades
- Meets OSHA standards

**TAT 30-45**

- Safety yellow heater enclosure with safety screens on both air intake and output openings.
- Optional 25' long SO type cord, ready for plug attachment is available for each model.
- Long-life finned tubular heating elements.
- Thermostat adjustment 120° to 150° F.
- Two 10" rear wheels and a front locking caster.
- High-limit thermal cutout switch with manual reset.
- 2200 CFM
- Fan only operation feature

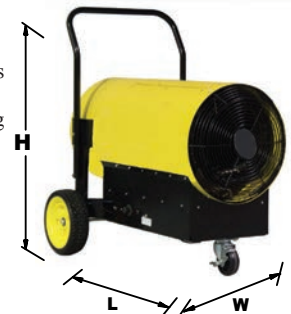

**CORD LENGTH: 25'  
18AWG SHIELDED CABLE**

**CORD LENGTH: 6'10"  
16AWG USASI HPN CORD**

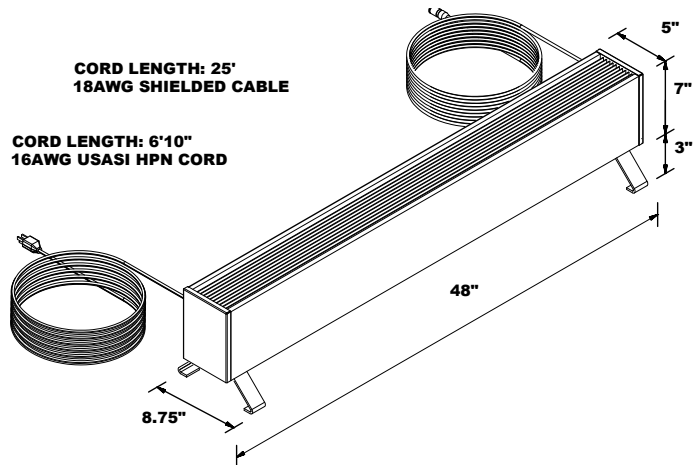

MODEL	DIMENSIONS			WT. (LBS)
	LENGTH	WIDTH	HEIGHT	
TAT-8-240-1	39"	26.5"	18"	180
TAT-5-240-1	39"	26.5"	18"	180
TAT-20-480-3	39"	30.5	18"	234
TAT-1-120-1	48"	8.5"	9.5"	23
Remote Timer	11"	3"	4.5"	5
TAT 30, 45	37"	24"	39"	115/125
TAT24-FAN-120V-1	10.5"	26"	26"	30



# Thermal Area Treatment Heaters

## How It Works:

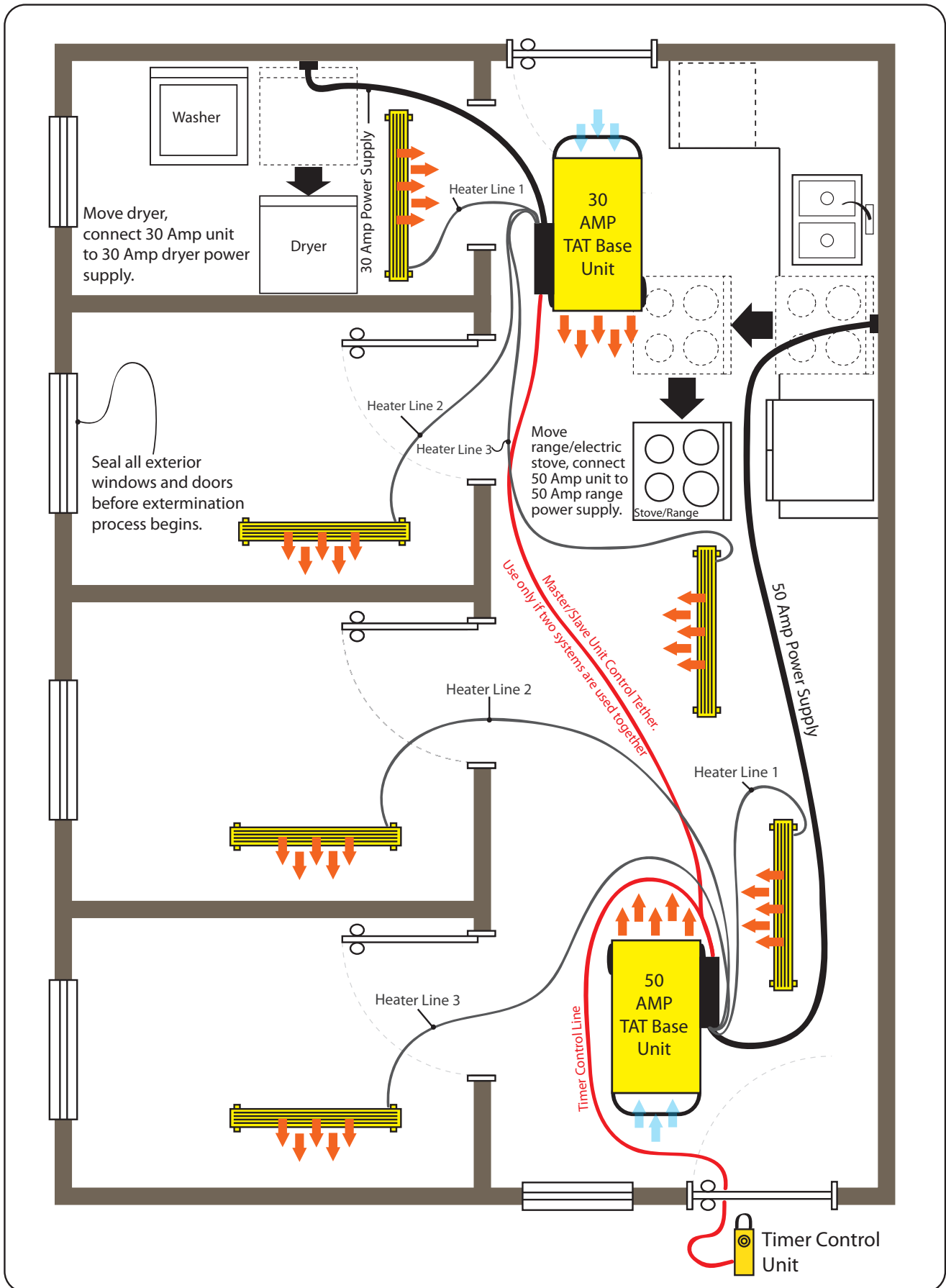
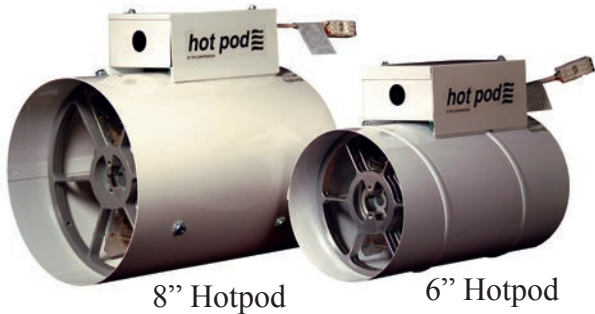

Diagram is for demonstrative purposes only and does not represent any actual structure or living environment. Two units may not be required for all situations, exterior climate, structure insulation, electrical service, and square footage all factor into effective treatment with this system.

# Hotpod™ Supplemental Duct Mounted Heating System



8" Hotpod

6" Hotpod



Patented  
Patent No. 8,285,127



## HotPod - Features

- Use to heat cold rooms or additions without upgrading central system
  - Fan only operation for increased cfm output for A/C cycles
  - 6" 1000/500 Watt and 8" 1440/720 Watt models available
  - Two stage operation
  - 120V corded and hard wire models available
  - 10' Cord length on corded models
  - Zero clearance for all models
  - All models include UT8003 low voltage thermostat
  - Optional wireless thermostat
  - Silent boot option available for rigid duct applications
- Note: Silent Boot can only be used with rigid duct work

## Standard HotPod Models

UPC# 686334	MODEL	DESCRIPTION	WATTS	VOLTS	MIN.CIRC. SIZE (AMP)	TEMP RISE (F)	WT	RPM	CFM	NEMA PLUG	DIMENSION L X W X H
290074	HP6-1000120-2T	6" INLET, HARDWIRE	1000/500	120	8.33	26	4	1500	130	NA	10 1/2 x 8 1/2 x 6
290043	HP6-1000120-2CT	6" INLET, WITH CORD SET	1000/500	120	8.33	26	4	1500	130	5-15P	10 1/2 x 8 1/2 x 6
290081	HP8-1440120-2T	8" INLET, HARDWIRE	1440/720	120	12.6	23	6	1500	210	NA	11 x 10 1/2 x 8
290067	HP8-1440120-2CT	8" INLET, WITH CORD SET	1440/720	120	12.6	23	6	1500	210	5-15P	11 x 10 1/2 x 8

## Multi-Pak Models - Includes 4 Hotpods

UPC# 686334	MODEL	DESCRIPTION	WATTS	VOLTS	MIN.CIRC. SIZE (AMP)	TEMP RISE (F)	WT. LBS	RPM	CFM	NEMA PLUG	DIMENSION L X W X H
290036	HP6-1000120-2T	4 PACK 6" INLET, HARDWIRE	1000/500	120	8.33	26	16	1500	130	NA	10 1/2 x 17 x 12
290111	HP6-1000120-2CT	4 PACK 6" INLET, WITH CORD SET	1000/500	120	8.33	26	16	1500	130	5-15P	10 1/2 x 17 x 12
290050	HP8-1440120-2T	4 PACK 8" INLET, HARDWIRE	1440/720	120	12.6	23	25	1500	210	NA	10 1/2 x 20 x 16
290128	HP8-1440120-2CT	4 PACK 8" INLET, WITH CORD SET	1440/720	120	12.6	23	25	1500	210	5-15P	10 1/2 x 20 x 16
290333	HP6H-12PK*	12 PACK 6" INLET, HARDWIRE	1000/500	120	8.33	26	58	1500	130	NA	21 x 14 1/2 x 43
290340	HP6C-12PK*	12 PACK 6" INLET, WITH CORD SET	1000/500	120	8.33	26	58	1500	130	5-15P	21 x 14 1/2 x 43
290357	HP8H-12PK*	12 PACK 8" INLET, HARDWIRE	1440/720	120	12.6	23	82	1500	210	NA	27 1/4 x 14 1/2 x 52
290364	HP8C-12PK*	12 PACK 8" INLET, WITH CORD SET	1440/720	120	12.6	23	82	1500	210	5-15P	27 1/4 x 14 1/2 x 52

\*includes 1 HotPod display

Note: Multi-Pak specifications (watts, volts, etc) are for each individual hotpod in the pack excluding weight.

# Silent Booster™ Supplemental Duct Mounted Boosting System

## Silent Booster - Features

- 120V corded and hardwire models available
- Adds 120 CFM Boost to duct heating or ventilation applications
- Can utilize optional TPI SilentBoot™ for whisper quiet operation in rigid duct application.
- 14" of duct, 4" from register is all that is needed for installation
- Optional wireless thermostat can be utilized to control Silent Booster™ to increase room comfort

## Moisture Control System - Features

- 120V, 8" Ducted Booster Fan; De-humidistat included
- 6" to 8" adapters available
- Includes all ductwork and outside damper
- Uses Heavy Duty booster fan to eliminate humidity from basements, crawl spaces, or damp areas.

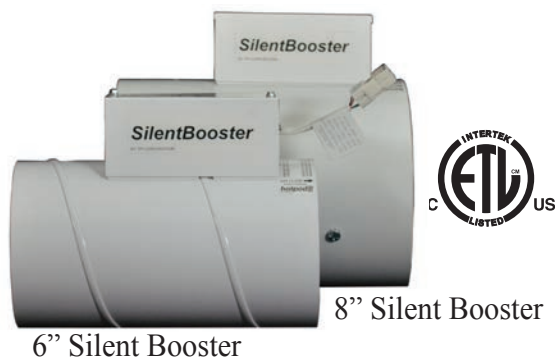

6" Silent Booster

8" Silent Booster



## Standard Silent Booster Models

UPC# 686334	MODEL	DESCRIPTION	VOLTS	MIN.CIRC. SIZE (AMP)	WT	RPM	CFM	NEMA PLUG	DIMENSION L X W X H
290371	SB6-120-T	6" SILENT BOOSTER (Hardwire)	120	15	4	1500	130	NA	10 1/2 x 8 1/2 x 6
290388	SB6-120-CT	6" SILENT BOOSTER (w/Cord Set)	120	15	4	1500	130	5-15P	10 1/2 x 8 1/2 x 6
290395	SB8-120-T	8" SILENT BOOSTER (Hardwire)	120	15	4	1500	210	NA	11 x 10 1/2 x 8
290401	SB8-120-CT	8" SILENT BOOSTER (w/Cord Set)	120	15	4	1500	210	5-15P	11 x 10 1/2 x 8
MOISTURE CONTROL SYSTEM									
290418	MCS120-8CT	8" MOISTURE CONTROL SYSTEM	120	15	4	1500	210	5-15P	11 x 10 1/2 x 8

## Hotpod Accessories And Thermostat

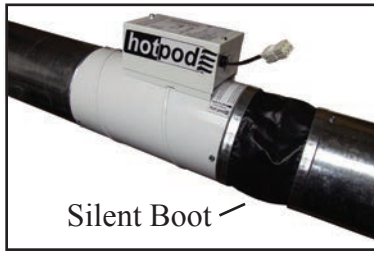

Silent Boot

UPC#	MODEL	DESCRIPTION	WT
686334			
290098	SB-6*	6" SILENT BOOT	4
290104	SB-8*	8" SILENT BOOT	4
523578	RFKIT-5	WIRELESS TRANSMITTER	6

\* Can be used with Hotpod models as a noise attenuator

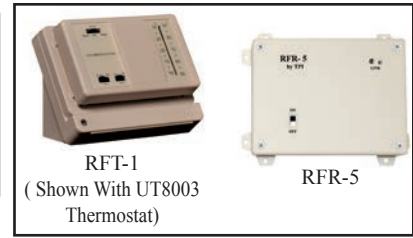

RFT-1  
(Shown With UT8003  
Thermostat)

RFR-5

RFKIT-5 - Patent Pending

## Hotpod Ready-Pack Self Contained Systems



Ready-Pack self contained system  
Note: does not mount to existing duct work.

### Features

- Includes all you need to install a complete Hotpod system
- Ideal for room or office additions
- RF Thermostat is standard with our Ready-Pack models, simplifying installation even further - Eliminates the need for thermostat wiring.
- Same specifications for 6" and 8" Hotpod models apply to Ready-Pack models.

### What's Included

- 6" or 8" Hotpod with RFKIT-5 wireless thermostat and transmitter
- One outlet and one return air grill
- Two 90 degree elbows
- Flexible duct (12.5')
- 8" models include 2 reducers - 8" to 6"

MODEL	DESCRIPTION
HP6-1000120-2TRP	6" INLET, 1000W, 120V, READY-PACK
HP6-1000120-2CTRP	6" INLET, 1000W, 120V, READY-PACK WITH CORDSET
HP8-1440120-2TRP	8" INLET, 1440W, 120V, READY-PACK
HP8-1440120-2CTRP	8" INLET, 1440W, 120V, READY-PACK WITH CORDSET

## MFH Series Hotpod - For those LARGER areas



### Features

- When the standard Hotpod is not enough
- 240V model has 6' cord set with a NEMA-6-15P Plug
- Unit contains air flow switch
- Zero inch (0") clearance installation
- All units are shipped with our UT8003 low voltage thermostat
- All units obtain a 33 degree temperature rise
- RP models are Ready-Pack models and do not need existing duct work

### Standard Models

UPC#	MODEL	DESCRIPTION	WATTS	VOLTS	WT	CFM	RPM
686334							
290135	MFHE-0300-6-EAA	6" INLETS, 1500 W, 120V, 2 STAGE THERMOSTAT	1500	120	132	250	1500
290197	MFHE-0300-6-EAARP	UNIT ABOVE WITH FLEX, BOOTS, GRILLS	1500	120	145	250	1500
290142	MFHE-0300-6-EAAC	6" INLETS, 1500 W, 120V, 2 STAGE THERMOSTAT, CORD	1500	120	132	250	1500
290203	MFHE-0300-6-EAACRP	UNIT ABOVE WITH FLEX, BOOTS, GRILLS	1500	120	145	250	1500
290173	MFHE-0300-6-HAA	6" INLETS, 2000W, 240V, 2 STAGE THERMOSTAT	2000	240	132	250	1500
290234	MFHE-0300-6-HAARP	UNIT ABOVE WITH FLEX, BOOTS, GRILLS	2000	240	145	250	1500
290159	MFHE-0300-8-EAA	8" INLETS, 1500W, 120V, 2 STAGE THERMOSTAT	1500	120	135	250	1500
290210	MFHE-0300-8-EAARP	UNIT ABOVE WITH FLEX, BOOTS, GRILLS, REDUCERS	1500	120	148	250	1500
290166	MFHE-0300-8-EAAC	8" INLETS, 1500W, 120V, 2 STAGE THERMOSTAT, CORD	1500	120	135	250	1500
290227	MFHE-0300-8-EAACRP	UNIT ABOVE WITH FLEX, BOOTS, GRILLS, REDUCERS	1500	120	148	250	1500
290180	MFHE-0300-8-HAA	8" INLETS, 3000W, 240V, 2 STAGE THERMOSTAT	3000	240	135	250	1500
290241	MFHE-0300-8-HAARP	UNIT ABOVE WITH FLEX, BOOTS, GRILLS, REDUCERS	3000	240	148	250	1500

## Fresh Air Make Up Units - Features

- Can be used with existing systems for fresh air intake
- Includes replaceable filter
- All units include duct stat and disconnect switch
- Available with 6" inlet and outlet only

### Standard Models

UPC#	MODEL	DESCRIPTION	CFM	RPM
686334				
290258	MFHE-0300-6-HAAF2D	6" INLETS, 3000W, 240V, FILTER, DUCT STAT	250	1500
290265	MFHE-0300-6-FAAF2D	6" INLETS, 2000W, 208V, FILTER, DUCT STAT	250	1500

# 7200 Series Plenum Heater



Manufactured in U.S.A.

## HOW TO DESIGNATE A MODEL:

<b>F</b>	<b>3</b>	<b>E</b>	<b>72</b>	<b>15</b>	<b>2</b>	<b>T</b>
Element Voltage F = 208V H = 240V G = 277V P = 480V	Phase 1 = Single Phase 3 = Three Phase	Motor Voltage E = 120 G = 277 P = 480	Series Number	Element KW 3KW through 50KW See model chart for KW options.	Heater Stages Blank = One 2 = Two	Control System T = Unit Thermostat SSR = SSR Control Blank = None

## Product Specifications

- 20 gauge galvanized cabinet.
- Variable speed motor, factory set at maximum. Motor speed can be field adjusted to increase heat rise.
- Acoustically insulated with 1" fiberglass.
- Access panels on both sides of cabinet.
- 24 Volt controls.
- Air flow switch.
- Terminal blocks.
- Single point connection.
- Dust tight control enclosure.
- Filter rack on inlet with throw away filter.
- Inlet and outlet screens and duct connection.
- Automatic primary limit control and secondary fuse link.
- Optional wall thermostat, unit thermostat or SSR control which proportionally regulates heat output.
- Disconnect switch.

## Standard Models

UPC# 686334	MODEL	KW	CFM RANGE	VOLTS / PHASE	TOTAL AMPS for MOTOR & HEATER	STAGE	MOTOR VOLTAGE	FULL LOAD AMPS for MOTOR ONLY	MOTOR H.P.	WT. (LBS)
617680	F1G7203	3	70-270	208/1	15.4	1	277	1	1/15	98
606561	H1G7203			240/1	13.5		277	1		
606240	G1G7203			277/1	11.83		277	1		
606905	F3G7203			208/3	9.32		277	1		
617765	H3G7203			240/3	8.21		277	1		
617574	P3G7203			480/3	4.6		277	1		
617666	F1G7205	5	200-650	208/1	25.13	1	277	1.1	1/6	118
617956	H1G7205			240/1	21.93		277	1.1		
606165	G1G7205			277/1	19.15		277	1.1		
606424	F3G7205			208/3	14.97		277	1.1		
617994	H3G7205			240/3	13.12		277	1.1		
606110	P3G7205			480/3	7.11		277	1.1		
606554	F3E7210	10	500-1200	208/3	33.05	1	120	5.3	1/4	141
617734	H3G7210			240/3	25.75		277	1.7		
617581	P3G7210			480/3	13.72		277	1.7		
606516	F3E7210-2			208/3	33.05		120	5.3		
534390	H3G7210-2			240/3	25.75		277	1.7		
617659	P3G7210-2			480/3	13.72		277	1.7		
608602	F3E7215	15	500-1200	208/3	46.93	1	120	5.3	1/4	141
608848	H3G7215			240/3	37.78		277	1.7		
606257	P3G7215			480/3	19.74		277	1.7		
606943	F3E7215-2			208/3	46.93		120	5.3		
534406	H3G7215-2			240/3	37.78		277	1.7		
606066	P3G7215-2			480/3	19.74		277	1.7		
608831	F3E7220-2	20	750-1600	208/3	63.81	2	120	8.3	1/2	163
534413	H3G7220-2			240/3	50.61		277	2.5		
606394	P3G7220-2			480/3	26.55		277	2.5		
534420	F3E7223-2	23	1300-2000	208/3	74.84	2	120	11	3/4	201
617888	H3G7223-2			240/3	59.63		277	4.3		
606875	P3G7225-2			480/3	34.37		277	4.3		
534437	H3G7230-2	30	1800-2800	240/3	78.47	2	277	6.3	2 MOTORS @ 1/2 H.P. EACH	278
606745	P3G7230-2			480/3	42.38		277	6.3		
618007	P3G7235-2			480/3	48.39		277	6.3		
606851	P3G7240-2	40	2000-3600	480/3	56.71	2	277	8.6	2 MOTORS @ 3/4 H.P. EACH	319
534444	P3G7245-2			480/3	62.72		277	8.6		
606417	P3G7250-2			480/3	68.74		277	8.6		

SSR proportional control maximum: 45 Amps

Note: Products listed in this section are custom built and subject to 100% cancellation/restock charges.



# 7200 Series Plenum Heater

## Product Dimensions

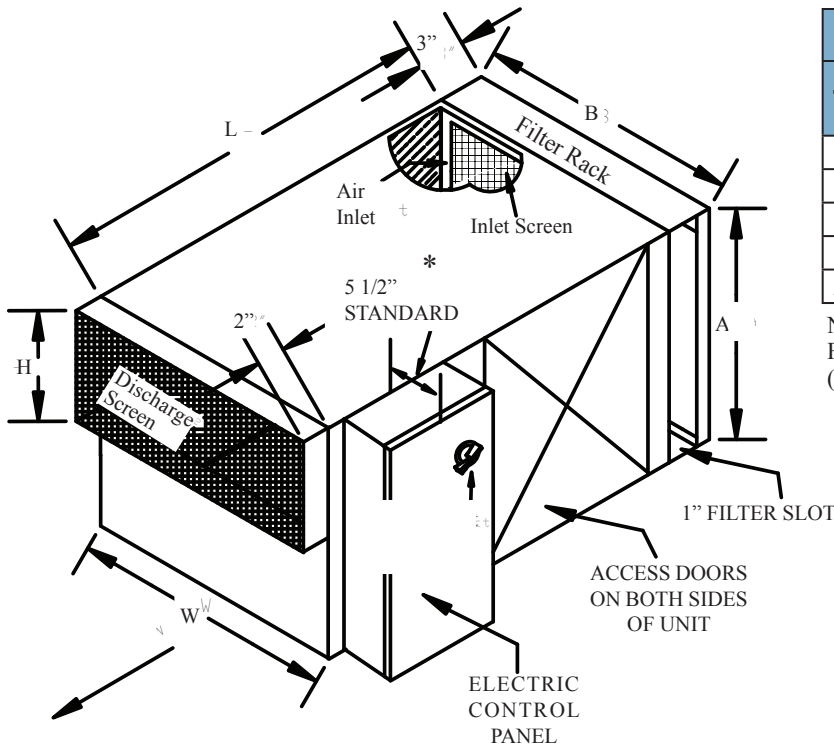

DIMENSIONS					
7200 Series	A	B	L	DISCHARGE	
				W	H
3 KW	12"	14"	28"	14"	8"
5 KW	14"	18"	36"	18"	8"
10 & 15 KW	18"	18"	36"	18"	10"
20 KW	18"	22"	36"	22"	10"
23 & 25 KW	18"	26"	36"	26"	10"

Note: Control panel access standard as shown. For panel on opposite side access specify and order (Figure 5).

\* Control box depth depends on actual components. Consult factory for exact dimensions.

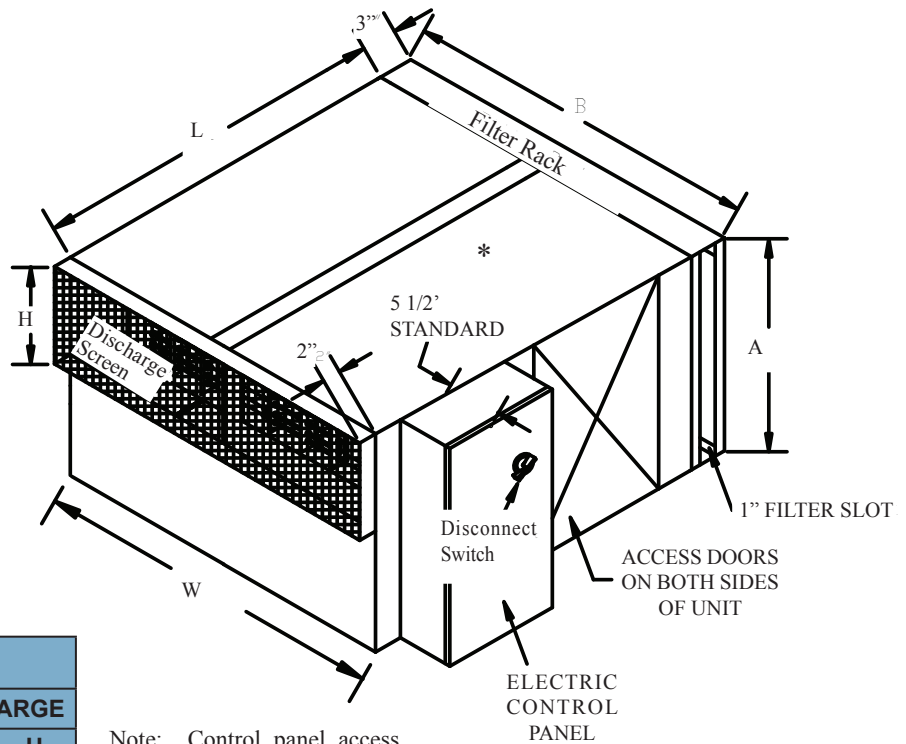

DIMENSIONS					
7200 Series	A	B	L	DISCHARGE	
				W	H
25-30-35 KW	18"	44"	36"	44"	10"
40-45-50 KW	18"	52"	36"	52"	10"

Note: Control panel access standard as shown. For panel on opposite side access specify and order (Figure 5).

# 7300 Series Plenum Heater

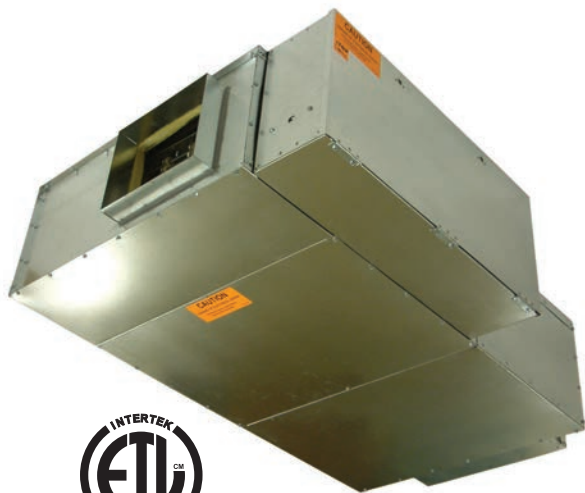

Manufactured in U.S.A.

## HOW TO DESIGNATE A MODEL:

<b>F</b>	<b>3</b>	<b>E</b>	<b>73</b>	<b>15</b>	<b>2</b>	<b>T</b>
Element Voltage F = 208V H = 240V G = 277V P = 480V	Phase 1 = Single Phase 3 = Three Phase	Motor Voltage E = 120 G = 277 P = 480	Series Number	Element KW 3KW through 18KW See model chart for KW options.	Heater Stages Blank = One 2 = Two	Control System Blank = None T = Unit Thermostat SSR = SSR Control

The 7300 Series LowBoy Plenum Heater is designed to fit jobs where the clear space between the ceiling and the floor above is as small as 11-3/4 inches.

### Product Specifications

- 20 gauge galvanized cabinet.
- Variable speed motor, factory set at maximum. Motor speed can be field adjusted to increase heat rise.
- Acoustically insulated with 1" fiberglass.
- Access panels on bottom of unit.
- 24 Volt controls.
- Air flow switch.
- Terminal blocks.
- Single point connection.
- Dust tight control enclosure.
- Filter rack on inlet with throw away filter.
- Inlet and outlet screens and duct connection.
- Automatic primary limit control.
- Optional wall thermostat, unit thermostat or SSR control which proportionally regulates heat output.
- Disconnect switch.

### Standard Models

UPC# 686334	MODEL	KW	CFM RANGE	VOLTS/ PHASE	TOTAL AMPS for MOTOR & HEATER	STAGE	MOTOR VOLTAGE	FULL LOAD AMPS for MOTOR ONLY	MOTOR H.P.	WT. (LBS)			
618076	F1G7305	5	170-950	208/1	26	1	277	2	1/4	163			
617543	H1G7305			240/1	22								
606301	G1G7305			277/1	20								
617642	F3G7305			208/3	15								
534451	H3G7305			240/3	14								
606455	P3G7305			480/3	8								
609968	F3E7310	10	170-950	208/3	32	1	120	4					
617734	H3G7310			240/3	26								
617598	P3G7310			480/3	14								
606363	F3E7310-2			208/3	32						2	277	2
534468	H3G7310-2			240/3	26								
617697	P3G7310-2			480/3	14								
534482	H3G7312	12	270-1500	240/3	32	1	277	3					
534499	P3G7312			480/3	17								
608596	F3E7312-2			208/3	41				2	120			
534505	H3G7312-2			240/3	32								
617703	P3G7312-2			480/3	17								
534529	H3G7315			15	270-1500						240/3	39	1
608725	P3G7315	480/3	21										
618106	F3E7315-2	208/3	49			2	120	8					
608510	H3G7315-2	240/3	39										
617536	P3G7315-2	480/3	21										
608763	P3G7318	18	270-1500						480/3	25	1	277	
606189	P3G7318-2			480/3	25				2	277			3

SSR proportional control maximum: 45 Amps

Note: Products listed in this section are custom built and subject to 100% cancellation/restock charges.

# 7300 Series Plenum Heater

## Product Dimensions

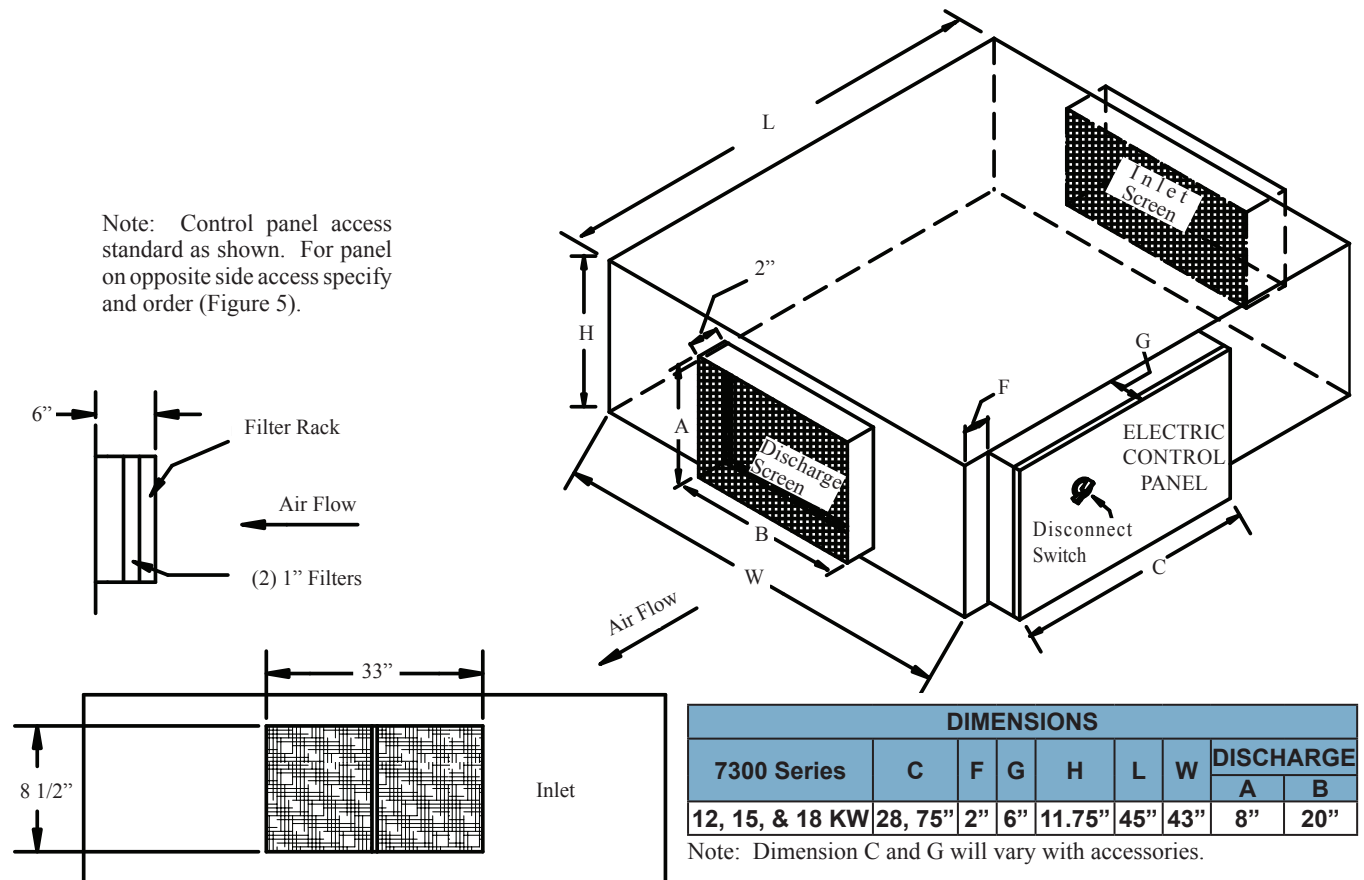
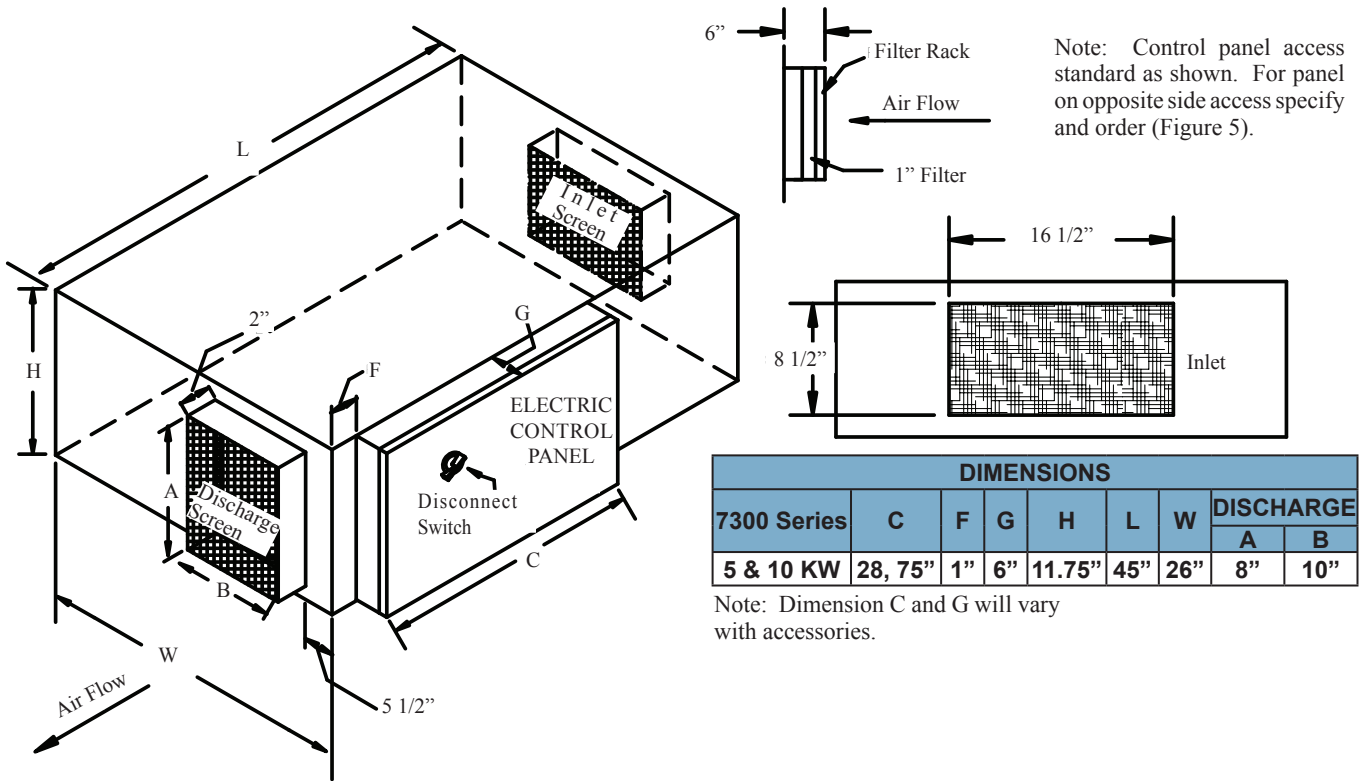

# PD Series Packaged Duct Heater

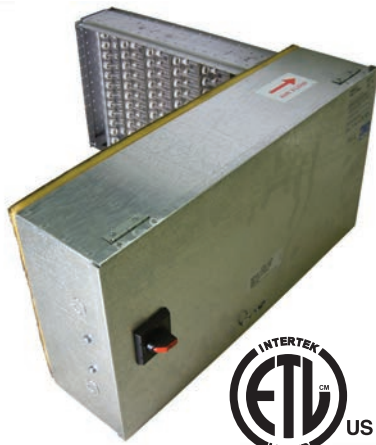

Manufactured in U.S.A.

## Standard Features

- Galvanized Steel Element Rack - Always 1” shorter than duct height and 1/2” shorter than duct width to allow insertion clearance
- Galvanized Steel Compartment with 1/2” fiberglass Insulation & Hinged Cover
- Door Interlock Disconnect Switch
- Primary Automatic Reset Temp Limiting Control
- Load Carrying Secondary over Temperature Protective Device(s)
- Definite Purpose Magnetic Contactor(s)
- Differential Pressure Fan Inter-lock Switch
- Step Down Control Transformer / 24 Volt
- Permanently Attached Wiring Diagram on inside of Terminal Compartment Cover

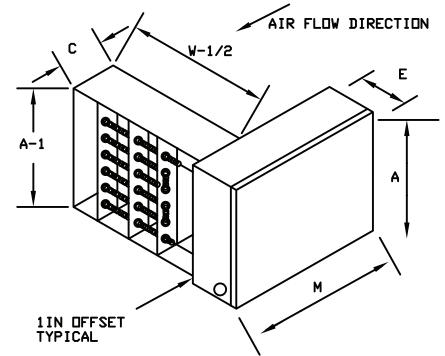

## Standard Models

UPC 686334	MODEL NUMBER	KW	POWER VOLTS/ PHASE	DUCT WIDTH W	DUCT HEIGHT A	DIMENSIONS			AMPS	CONTROL STEPS	WT. (LBS.)	
						C	E	M				
617000	PD5-128-1	5	240-1	12	8	4.75	6.5	26	20.9	1	22	
617017	PD10-1810-1	10		18	10	4.75	6.5	28	41.7	2	37	
617024	PD15-1812-1	15		18	12	4.75	6.5	27	62.5	2	33	
617031	PD20-2012-1	20		20	12	9.125	7.5	31	83.3	2	37	
617048	PD25-2016-1	25		20	16	9.125	7.5	38	104.2	3	56	
617055	7PD2-128-1	2	277-1	12	8	4.75	6.5	26	7.2	1	21	
617062	7PD3.5-128-1	3.5							12.6			
617079	7PD5-128-1	5							18.1			
617086	8PD5-128-3	5	208-3	12	8	4.75	6.5	26	13.9	1	22	
617093	8PD10-1810-3	10		18	10	4.75	6.5	22	27.8	1	27	
617109	8PD15-1812-3	15		18	12	9.125	6.5	25	41.7	1	32	
617116	8PD15-1812-2-3	15		18	12	9.125	6.5	28	41.7	2	34	
617123	8PD20-2012-3	20		20	12	9.125	6.5	40	55.6	2	39	
617130	8PD25-2016-3	25		20	16	9.125	6.5	29	69.5	2	58	
617147	8PD30-2416-2-3	30		24	16	9.125	7.5	29	83.4	2	65	
617154	8PD30-2416-3	30		24	16	9.125	7.5	35	83.4	3	60	
617437	8PD35-2416-3	35		24	16	9.125	7.5	35	97.3	3	65	
617321	8PD40-2416-3	40		24	16	9.125	7.5	43	111.2	3	75	
617338	8PD45-3016-3	45		30	16	9.125	7.5	43	125.1	3	80	
617345	8PD50-3016-3	50		30	16	9.125	7.5	43	139	3	85	
617161	PD-128-3	5		240-3	12	8	4.75	6.5	26	12.1	1	21
617178	PD10-1812-3	10			18	10	4.75	6.5	22	24.1	1	26
617185	PD15-1812-1-3	15			18	12	4.75	6.5	20	36.2	1	30
617192	PD15-1812-2-3	15	18		12	9.125	6.5	26	36.2	2	33	
617208	PD20-2012-3	19.9	20		12	9.125	6.5	28	47.9	2	39	
617215	PD25-2016-3	25	20		16	9.125	6.5	29	60.2	2	57	
617222	PD30-2416-2-3	30	24		16	4.75	6.5	25	72.3	2	57	
617239	PD30-2416-3-3	30	24		16	9.125	6.5	35	72.3	3	65	
617352	PD35-2416-3	35	24		16	9.125	7.5	35	84.3	3	65	
617369	PD40-2416-3	40	24		16	9.125	7.5	35	96.3	3	75	
617376	PD45-3016-3	45	30		16	9.125	7.5	43	108.4	3	80	
617383	PD50-3016-3	49.8	30		16	9.125	7.5	43	120	3	85	
617246	4PD5-128-3	5	480-3		12	8	4.75	6.5	26	6.1	1	21
617253	4PD10-1810-3	10			18	10	4.75	6.5	22	12.1	1	26
617260	4PD15-1812-3	15			18	12	4.75	6.5	20	18.1	1	30
617277	4PD15-1812-2-3	15		18	12	9.125	6.5	26	18.1	2	34	
617284	4PD20-2012-3	20		20	12	9.125	6.5	26	24.1	2	39	
617291	4PD25-2016-3	25		20	16	9.125	6.5	22	30.1	2	58	
617307	4PD30-2416-2-3	30		24	16	4.75	6.5	18	36.2	2	65	
617314	4PD30-2416-3-3	30		24	16	9.125	6.5	24	36.2	3	65	
617390	4PD35-2416-3	35		24	16	9.125	6.5	26	42.2	3	65	
617406	4PD40-2416-3	39.9		24	16	9.125	6.5	40	48.1	3	75	
617420	4PD50-3016-3	50		30	16	9.125	6.5	36	60.2	3	85	



# CHMS Series Finned Tubular Element Duct Heater

Finned tubular duct heaters provide many benefits to the customer. They provide slower heating and cooling for closer temperature regulation, electrical shock hazards are reduced, not as susceptible to shorting on the elements, are easily serviced, and better withstand physical abuse.

- Insert or Flanged construction
- Integral or remote control panels
- Available with Nema 4-4x-12 control panels
- ABS type approved



Manufactured in U.S.A.

HOW TO DESIGNATE A MODEL:

CHMS	3	I	18W	12H	15KW	480	3	24	2	HL	1
Duct Heater Series	Control Box Options 3 = Control Box on Heater, R = Remote	Construction Options F = Flange Mount, I = Insert	Duct Width Dimension (over .55" heater must be flanged)	Duct Height Dimension	Kilowatts	Power Supply Volts	Phase 1 = Single Phase, 3 = Three Phase	Control Volts 24, 120, 240, & 277	Number of Control Stages	Air Flow Direction	Internal Duct Insulation 0 = None, 1 = 1" Thick, 2 = 2" Thick

NOTE: All blanks must be filled in when submitting an order to the factory.

MINIMUM HEATER SIZE 8" X 8"  
MAX KW 18.1 KW PER SQ. FT.

## Product Specifications

### General

1. Provide Series "CHMS" enclosed element electric duct heaters as manufactured and listed on schedule.
2. Power, voltage phase, control voltage, wattage, duct size, number of steps to be per schedule.
3. Heaters to be either slip-in or flanged type as called for on schedule.
4. All heaters to be ETL listed for zero clearance to combustible surfaces and bear ETL label.
5. All heaters shall meet the requirements of the National Electric Code.
6. Standard terminal box, recessed terminal box, standard control cabinet, remote control cabinet and element housing to be made of 18 gauge aluminized steel.

### Element Construction

1. All elements to be made of high quality alloy resistor wire, centered and permanently encased within highly compacted, rock-hard refractory material, surrounded by stainless steel sheath. All element terminations shall be threaded stainless steel type to insure a positive connection to leads.

### Terminal Box or Control Cabinet

1. Shall be constructed of 18 gauge Aluminized steel. All boxes to have a solid cover of the same gauge, complete with a piano type hinge on the longest dimension, tool operated latch and pull ring.

### Safety Controls

1. Primary over temperature protection shall be provided by built-in capillary type automatic reset thermal cutout. Capillary cutout shall be U.L. listed and of the fail safe type.
2. Secondary over temperature protection shall consist of a sufficient number of capillary type manual resets controlling back-up contactors. Capillary shall be the "fail safe" and "trip free" type.
3. All capillaries shall be installed in a protective Aluminum sheath. Sheath shall be etched and painted flat black to sense any over temperature condition the full length of heater face.
4. Over-current protection incorporating fuses must be provided for all heaters rated more than 48 Amperes, and factory installed, within the heater enclosure or provided as a separate assembly by the heater manufacturer. Heaters exceeding 48 Amperes total line current must be divided into sub-circuits of less than 48 Amperes and be protected at not more than 60 Amperes.

### Wiring Diagrams

1. A separate, complete and specific wiring diagram shall be permanently attached to each heater. Typical wiring diagrams are not acceptable.
2. Control and line terminals in each heater shall be marked to correspond to the wiring diagram.

### Air Flow Designations Guide for CHMS Series Duct Heaters

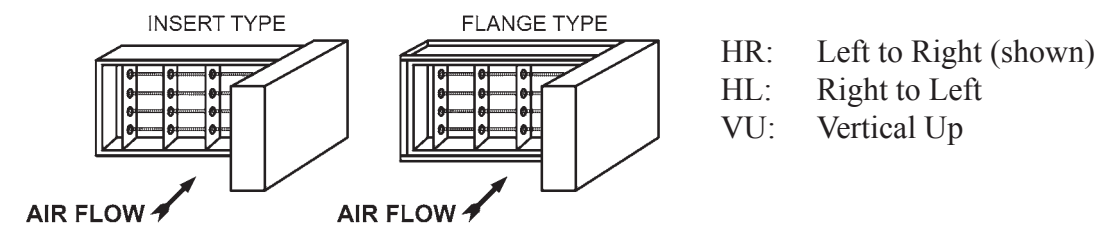

Control panel standard is extended upstream and same height as duct. This can be altered to accommodate available space.

# HF Series Open Coil Element Duct Heater



Open coil duct heaters offer several advantages when used properly. They release heat directly into the air stream resulting in lower element temperatures, provide higher wattage per square foot of duct area, have low pressure drop due to high percentage of open area, are light weight, easily installed, and economical with quick delivery available.



Manufactured in U.S.A.

### Standard Features

- Galvanized steel control box with optional 1/2" insulation and hinged cover.
- Primary and secondary over temperature protection.
- De-energizing definite purpose contactors.
- Differential pressure fan interlock.
- 24 Volt control transformer.
- Fusing over 48 Amps (per NEC).
- Line terminal blocks.

- Insert or Flange.
- Integral or remote controls.
- Standard NEMA 1 control.
- Panel - available with NEMA 4-4x -12 panels as option integral or remote mounted.
- Comply with NEC specification.

### Custom Specified Models

How to designate an HF Series open coil duct heater:

480	3	HF	10KW	12W	12H	24	2	HR	B	G
<u>Volts</u>	<u>Phase</u>	<u>Model</u>	<u>Kilowatts</u>	<u>Width</u>	<u>Height</u>	<u>Control Volts</u>	<u>Stage</u>	<u>Air Flow</u>	<u>Options</u>	<u>Options</u>

### Optional Controls & Features

- |   |  |
|---|--|
| A: Additional Stage                           | B: "A" Alloy Element Wire                      |
| C: Disconnecting Contactors                   | D: PE Switch                                   |
| E: Minimum fusing under 48 Amps               | F: Flanged Construction                        |
| G: Door Interlock Disconnect Switch           | H <sub>1</sub> : SCR Control Single Phase Only |
| H <sub>3</sub> : SCR Control Three Phase Only | I: NEMA 1 Dust Tight Control Box               |
| J: Electronic Step Controller                 |  |

### Air Flow Designations Guide for HF Series Duct Heaters

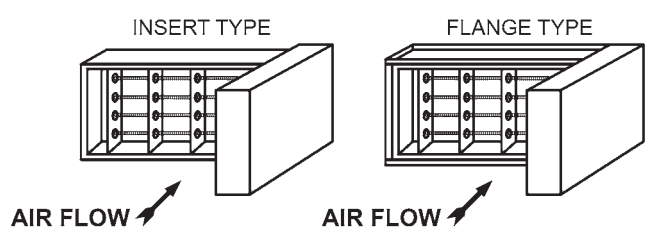

- HR: Left to Right (shown)
- HL: Right to Left
- VU: Vertical Up
- D: Vertical Down

Control panel standard is extended upstream and same height as duct. This can be altered to accommodate available space.

# HF Series Open Coil Element Duct Heater

## Product Specifications

### General

1. Provide open coil, electric duct heaters, as manufactured and as listed in the schedule.
2. Power voltage and phase, control voltage, wattage, duct size, number of steps to be as per schedule.
3. Heaters to be either Slip-in or Flanged type as called for.
4. Three phase heaters shall have balanced three phase steps unless specified otherwise.
5. All heaters to be ETL listed for zero clearance to combustible surfaces and bear the ETL label.
6. All heaters shall meet the requirements of the latest National Electric Code.
7. Standard terminal box, recessed terminal box, standard control cabinet, remote control cabinet as well as element housing and racks all to be made of heavy gauge galvanized steel. (Aluminized steel optional).
8. All heating coils to be made of high grade Nickel/Chromium resistance wire and terminated by means of a loop of wire being sandwiched between stainless steel or Nickel plated washers and terminal hardware. All terminal hardware to be insulated from the heater by a two piece ceramic bushing.

LINE VOLTS	KILOWATTS	STAGE
120 208 240	0.5-2.5	1
	2.6-5.0	
	5.1-8.0	
	8.1-11.0	
	11.1-15.0	
	15.1-19.0	2
	19.1-24.0	
	24.1-28.0	
	28.1-30.0	
	30.1-34.0	3
	34.1-38.0	
	38.1-42.0	
	42.1-46.0	
	46.1-51.6	
51.7-55.0	4	
55.1-60.0		
277	0.5-2.5	1
	2.6-5.0	
	5.1-8.0	2
	8.1-11.0	
480 600	11.1-15.0	1
	0.5-2.5	
	2.6-5.0	
	5.1-8.0	
	8.1-11.1	
	11.2-15.0	2
	15.1-19.0	
	19.1-24.0	
	24.1-28.0	
	28.1-30.0	3
	30.1-34.0	
	34.0-39.9	
	40.0-44.0	
	44.1-48.0	
48.1-53.0		
53.1-56.0		
56.1-60.0		

**Note:** Duct Heaters are available up to 1000KW. KW and stages shown above are limited example of available models.

### Wiring Diagrams

1. A separate, complete and specific wiring diagram shall be permanently attached to each heater. Typical wiring diagrams are not acceptable.
2. Control and line terminals in each heater shall be marked identical to the wiring diagram.

### Heater Controls

1. All heater controls shall be factory mounted and wired.
2. Contactors shall be definite purpose type. No application type relays will be acceptable.
3. All controls shall be furnished as specified.

### Element Assembly

1. To be of "Module" design with each module independently and easily removable from the terminal box or control cabinet.
2. Each module to contain no more than 2 layers of element coils so that any one coil may be replaced without disturbing others.
3. Element coils of each module to be on staggered spacing so that all coils per module will be in the air stream, and shadowing (overheating) and/or blank areas eliminated.

### Element Housing

1. To be of No. 18 gauge galvanized (aluminized) steel and to be of roll-formed construction with multiple brakes and ribs for stiffness and rigidity.

### Element Rack

1. To be constructed of No. 20 gauge galvanized (aluminized) steel and formed with multiple brakes and ribs for stiffness and rigidity.
2. Ceramic coil supports to be floating, but contained and easily replaceable.
3. Ceramic coil insulators to be on staggered spacing per rack to eliminate blank areas in the air pattern thru the heaters, and provide uniform heating over the entire cross section of the element.
4. Racks to support element coils on no more than 3 1/2" centers.

### Terminal Box or Control Cabinet

1. Shall be constructed of heavy gauge galvanized steel (aluminized optional) and in sizes up to 18" X 18" shall be No. 20 gauge and over to be No. 18 gauge. All boxes to have a solid cover, of the same gauge, complete with a piano type hinge on the longest side, approved tool operated latch and pull ring. Covers over 48" long to be provided with two latches and pull rings.
2. Insulation consisting of 1/2" high density fiberglass will be provided, attached to the cabinet, between the cabinet and the heating section.
3. Recessed terminal boxes used when ducts are internally insulated, or in air handling units, to be of the same general construction as item 1 above.

### Airflow Direction

Heaters will be interchangeable for mounting in a horizontal or vertical duct except when position sensitive Mercury contactors, SCR's or capillary type limit controls are built-in. In these cases, airflow direction is as specified.

### Safety Controls

1. Primary over temperature protection shall be provided by built in disc type automatic reset thermal cutouts for duct heaters up to 10' in width. Heaters over 40" high require two cutouts. Capillary type automatic reset thermal cutouts are required for any heater 10' wide or over. Capillary type controls to be UL listed and of the "fail safe" type.
2. Secondary over temperature protection shall consist of a sufficient number of load carrying replaceable disc controls to de-energize the elements if the primary system fails.
3. Fuse link type heat limiters shall not be acceptable. All manual safety devices shall be resettable thru the terminal box without removing the heater from the duct.

**MINIMUM DUCT  
SIZE 8" X 6"  
MAX KW 20 KW  
PER SQ. FT.**



Manufactured in U.S.A.



Discharge Grille



MFH - W Model



MFH - E Model

## Product Applications

### Perimeter Heating; Lobby Heating; Plenum Heating; Kitchen Make-up Air

The fan pac offers the advantages of eliminating large and unsightly roof-top package equipment, and through the roof duct systems which require costly installations with greater horsepower requirements.

### Commercial or Industrial Unit Heaters

Since the fan pac incorporates a centrifugal blower designed to operate at static pressures of up to .70 inches w.g., it is ideally suited for hanging in unused overhead spaces and forcing the warm air to occupied floor areas. Ductwork can also be utilized to circulate the heated or ventilated air over large areas that may not be in the vicinity of the fan pac.

## Product Construction, Options & Features

### Construction:

- All units ETL Listed as a total package with electric heat or hot water coils.
- Certified sound data by an independent testing laboratory.
- Single point pneumatic pipe connections.
- Each fan package is factory tested prior to shipment.
- Fan package, electric heat and optional disconnect switch are factory wired as a package.
- 20 gauge galvanized cabinet acoustically insulated 1" fiberglass.
- 1" 4 lb. density core insulation is U.L. Listed and meets NFPA 90A standards.
- Motors are single speed PSC with thermal over load protections, solid-state speed controller, and are permanently lubricated.
- Access panels to the blower and motor are placed on both sides of the cabinet.
- Fan and motor assembly is mounted on a special 16 Gauge pad and completely isolated from the casing with rubber vibration mounts.

### Features:

- The fan pac is a basic and very simple on/off operation for an application that requires a fan coil unit with electric or hot water heat and a static pressure duct system of up to .70 inches w.g.
- The unit can be energized by electric controls (line voltage or low voltage) or by P.E. switches in conjunction with a pneumatic system.
- SCR motor speed controller for continuous adjustable fan speed from minimum to maximum RPM.
- Built-in line voltage thermostats are available for unit heater type applications.
- Built-in control circuit transformers are available in 24V or 120V.
- Hot water coils are one row 1/2" O.D., two row 5/8" O.D. copper tubes. Aluminum fins are standard with 10 FPI spacing.
- Transformers for fan motors are NOT available.

### Options:

- Factory wired disconnect switch.
- Throw away filter.
- Permanent filter.
- Electric heat or hot water coils.
- Sealed access panels.
- 120 or 277 PSC motors.
- Dust tight electric panel.
- Acoustically lined discharge plenum or return air boot.



# MFH Series Fan Coil Units

## Product Specifications

The fan packages shall be factory assembled complete with electric heat/hot water coils. Factory mounted control panel shall provide all internal control and fan power wiring for a single point field connection. An optional factory mounted disconnect switch shall be furnished and prewired so as to disconnect all electrical components in the fan package. A single point field connection will be made at the disconnect switch. Fan package must be labeled and listed by a nationally recognized and locally accepted testing laboratory, such as ITS Intertek testing services. Fan packages must be tested for safety and in accordance with the latest National Electric Code. Casing shall be a minimum of 20 gauge galvanized steel and acoustically insulated with 1" fiberglass. The casing shall be Listed and meet NFPA and NBFU 90A requirements. Blower casing shall be constructed of heavy gauge steel and baked enamel finish. Fan wheel shall be forward curved centrifugal type, dynamically balanced and be driven by direct drive, single speed permanent split capacitor motors. Motors shall be single phase, 1050 RPM. An electronic motor speed control shall be provided to allow continuously adjustable fan speed from minimum to maximum and shall incorporate a minimum voltage stop to insure motor cannot operate in stall mode. Fan assembly shall be mounted on a 16 gauge steel sub-base, but shall be internally isolated with rubber-in-shear isolators to prevent vibration transfer to the sub-base. Motors shall also be isolated with rubber-in-shear isolators between the motor mounting legs and the blower casing. Fan motor assembly shall be accessible through access panels from both sides and rear of cabinet (bottom and top access panels are not acceptable). Access panels shall have gasket to prevent leakage and vibration transmission. An electric heater (hot water optional) shall be part of the total listed package and shall be controlled by pneumatic, electric controls enclosed in a NEMA-1 enclosure on the side of the cabinet. The panel shall be gasket sealed to prevent air leakage. Heater shall be the requested available voltage and phase. Each fan package will be factory tested prior to shipment and certified as such. Each fan shall have an optional throw-away or permanent filter, and an optional acoustically lined discharge plenum or return air boot.

## Custom Specified Models

### HOW TO DESIGNATE A MODEL:

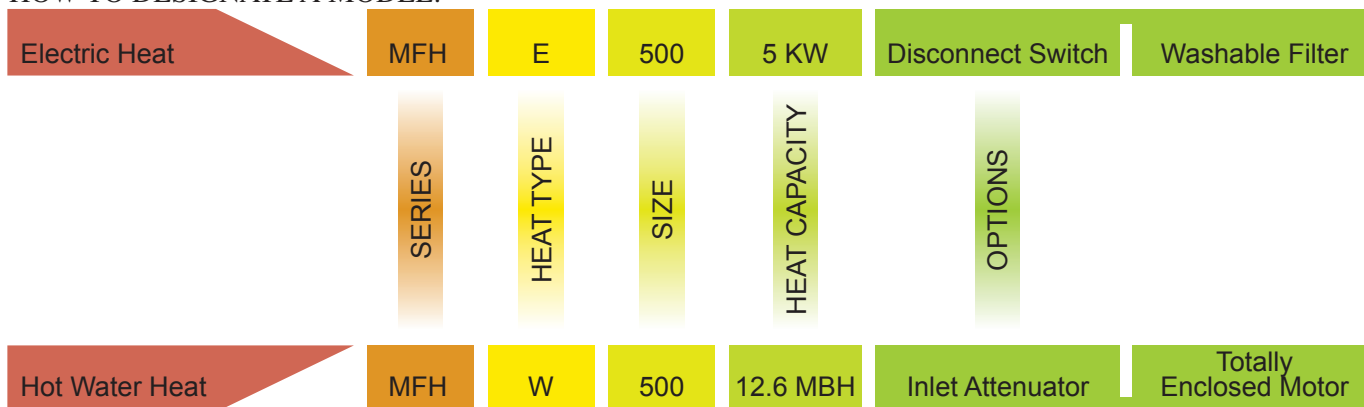

## Minimum CFM'S Based On KW

KW	5	7	9	10	
CFM	400	500	600	700	
KW	11	13	14	15	17
CFM	800	900	1000	1100	1200
KW	18	20	21	23	24
CFM	1300	1400	1500	1600	1700
KW	26	27	28.5	30	
CFM	1800	1900	2000	2100	

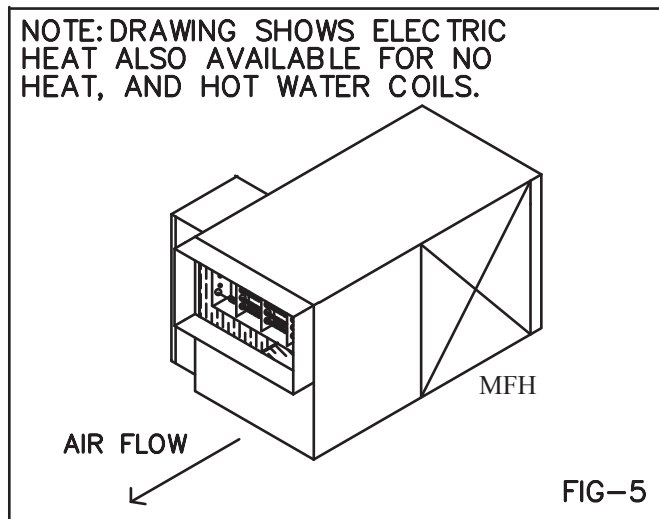
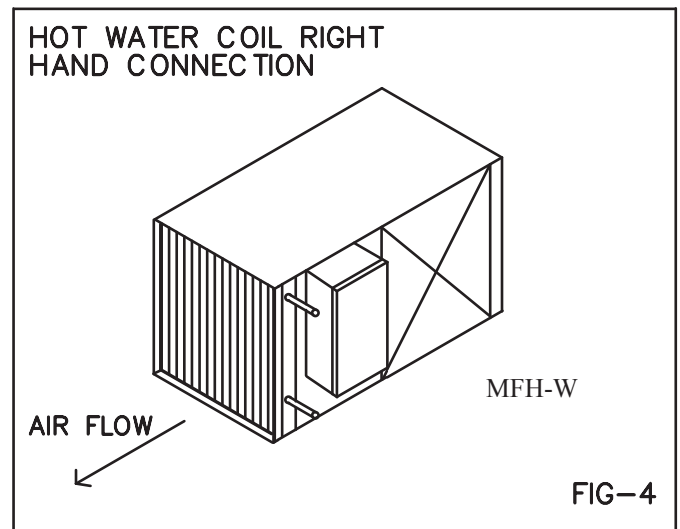
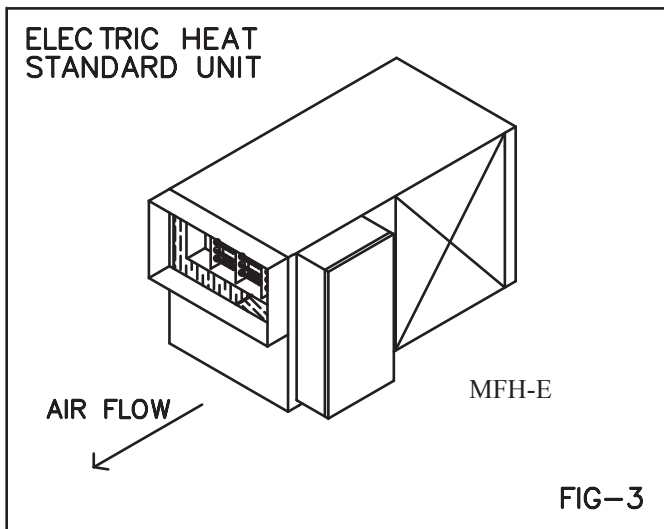
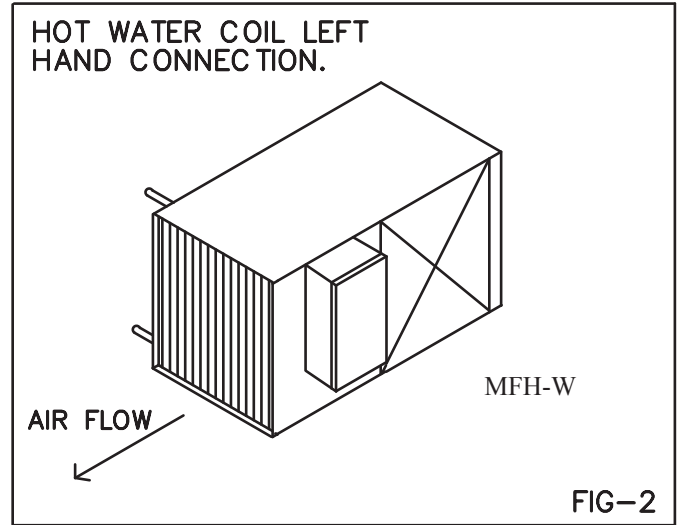
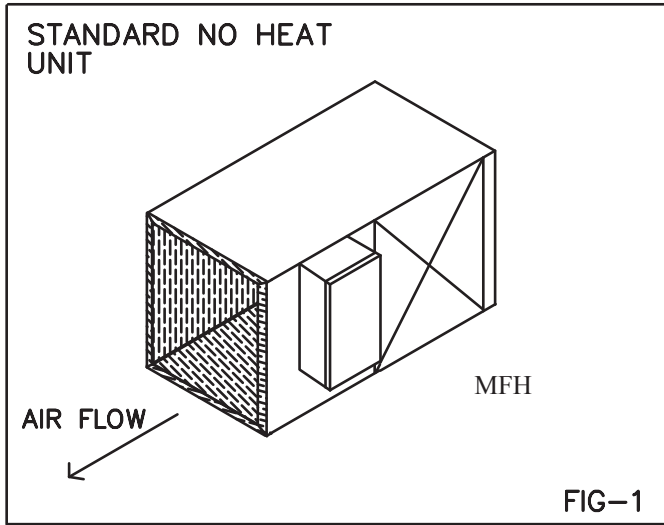

# MFH-E Series Fan Coil Units

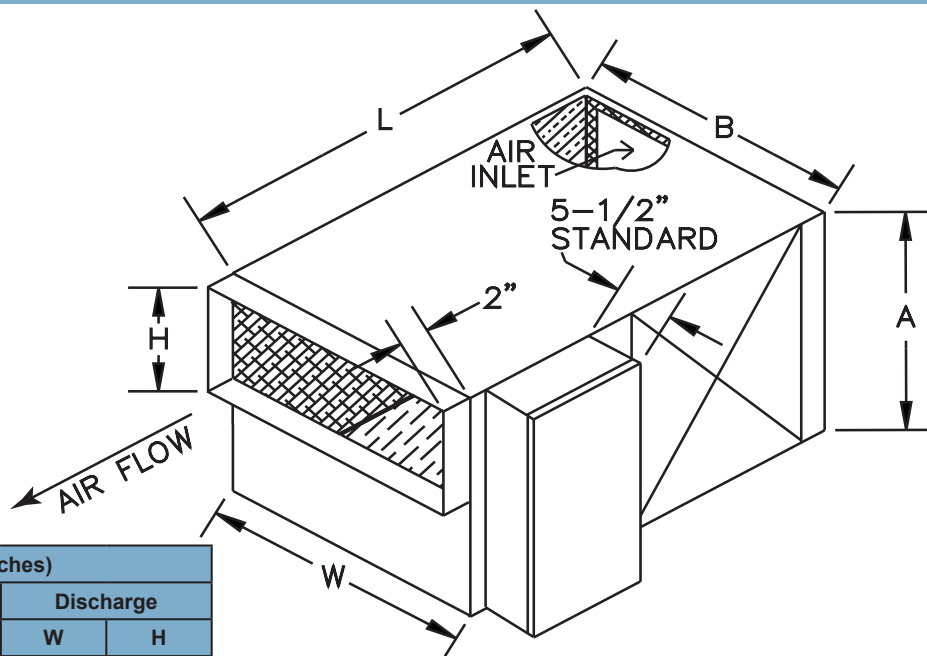

FAN PAC-Electric Heat

Model	Dimensions (Inches)				
	A	B	L	Discharge	
				W	H
300	12	14	28	14	8
500	14	18	36	18	8
750	18	18	36	18	10
1500	18	22	36	22	10
1800	18	26	36	26	10
2000	18	26	36	26	10
3000	18	44	36	44	10
4000	18	52	36	52	10

MFH PERFORMANCE DATA					MFH-E ELECTRIC HEAT						
MODEL	MOTOR H.P.	MOTOR AMPS	FULL LOAD AMPS	MOTOR SPEED CONTR.	EXTERNAL STATIC PRESSURE (in. H <sub>2</sub> O)						
					.1 CFM	.2 CFM	.3 CFM	.4 CFM	.5 CFM	.6 CFM	.7 CFM
300	1 @ 1/15	2.90	1.00	MAX	270	245	225	180	Below 50 CFM		
				MIN	95	85	80	70			
500	1 @ 1/6	3.60	1.10	MAX	740	700	640	590	530	490	450
				MIN	290	275	250	230	210	200	190
750	1 @ 1/4	5.30	1.70	MAX	1390	1370	1350	1270	1230	1130	1040
				MIN	450	440	430	420	410	405	400
1500	1 @ 1/2	8.30	2.50	MAX	1825	1790	1740	1660	1570	1450	1340
				MIN	820	790	760	675	590	515	440
1800	1 @ 1/2	9.70	3.10	MAX	2120	2080	2040	1940	1850	1750	1670
				MIN	850	840	820	810	790	740	630
2000	1 @ 3/4	11.00	4.30	MAX	2230	2160	2100	2040	1960	1860	1760
				MIN	1200	1120	1040	950	860	750	640
3000	2 @ 1/2	19.40	6.30	MAX	3160	3040	2920	2790	2600	2440	2240
				MIN	1840	1800	1760	1720	1640	1560	1460
4000	2 @ 3/4	22.00	8.60	MAX	4150	4050	3950	3830	3650	3250	3000
				MIN	2200	2180	2160	2130	2080	2000	1900

\*See minimum CFM chart for all electric coil selections.  
 208V and 240V units use 277V rated motors - F.L.A. on 208V and 240V units same as 277V. For fan curve data consult factory

Basic Weight (no options)	
Model	lbs.
300	95
500	115
750	138
1500	160
1800	175
2000	198
3000	275
4000	315

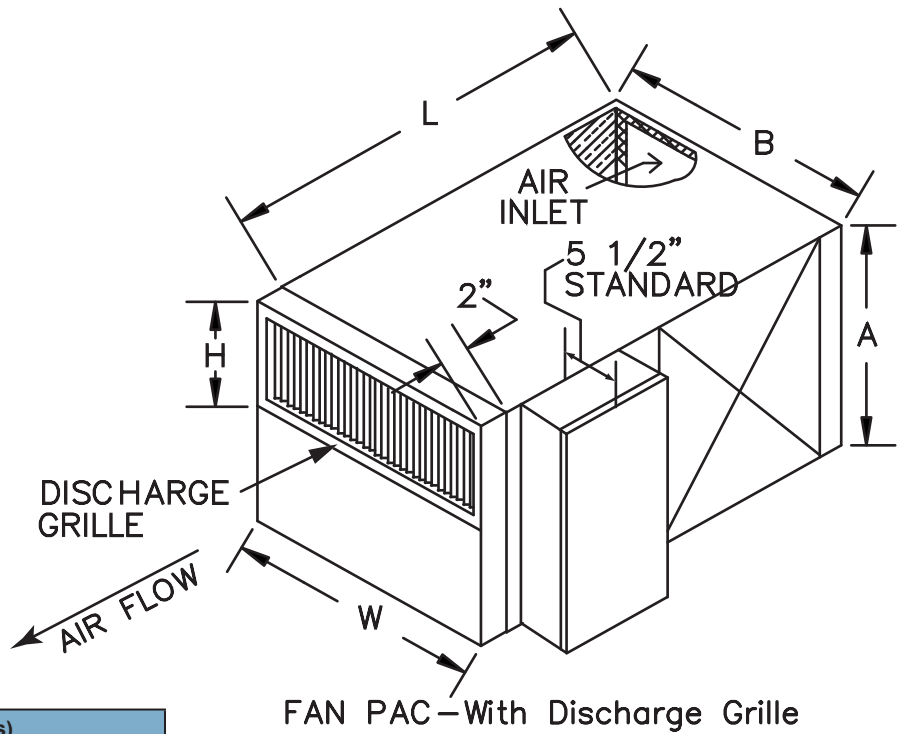

Model	Dimensions (Inches)			
	A	B	L	H
500	14	18	36	10
750	18	18	36	12
1500	18	22	36	12
1800	18	26	36	12
2000	18	26	36	12
3000	18	44	36	12
4000	18	52	36	12

MFH PERFORMANCE DATA					MFH-DG ELECTRIC HEAT DISCHARGE GRILL							
MODEL	MOTOR H.P.	MOTOR AMPS	FULL LOAD AMPS	MOTOR SPEED CONTR.	EXTERNAL STATIC PRESSURE (in. H <sub>2</sub> O)							
					.1 CFM	.2 CFM	.3 CFM	.4 CFM	.5 CFM	.6 CFM	.7 CFM	
		115V	277V									
300	1 @ 1/15	2.90	1.00	MAX	220	195	175	130	Below 50 CFM			
				MIN	95	85	80	70				
500	1 @ 1/6	3.60	1.10	MAX	640	600	540	490	430	390	350	
				MIN	290	275	250	230	210	200	190	
750	1 @ 1/4	5.30	1.70	MAX	1290	1270	1250	1170	1130	1030	940	
				MIN	450	440	430	420	410	405	400	
1500	1 @ 1/2	8.30	2.50	MAX	1725	1690	1640	1560	1470	1350	1240	
				MIN	820	790	760	675	590	515	440	
1800	1 @ 1/2	9.70	3.10	MAX	2020	1980	1940	1840	1750	1650	1570	
				MIN	850	840	820	810	790	740	630	
2000	1 @ 3/4	11.00	4.30	MAX	2130	2060	2000	1940	1860	1760	1660	
				MIN	1200	1120	1040	950	860	750	640	
3000	2 @ 1/2	19.40	6.30	MAX	3060	2940	2820	2960	2500	2340	2140	
				MIN	1840	1800	1760	1720	1640	1560	1460	
4000	2 @ 3/4	22.00	8.60	MAX	4050	3950	3850	3730	3550	3150	2900	
				MIN	2200	2180	2160	2130	2080	2000	1900	

\*See minimum CFM chart for all electric coil selections.  
208V and 240V units use 277V rated motors - F.L.A. on 208V and 240V units same as 277V. For fan curve data consult factory



DIMENSIONS					
MODEL	A	B	L	DISCHARGE	
				W	H
300	12'	14'	28'	14'	12'
500	14'	18'	36'	18'	14'
750	18'	18'	36'	18'	18'
1500	18'	22'	36'	22'	18'
1800	18'	26'	36'	26'	18'
2000	18'	26'	36'	26'	18'

**FAN PAC WITH HOT WATER HEAT** DATE 6-29-01

Altitude Correction Factors	
Alt. Ft.	Heat Factor
0	1.00
2000	0.94
3000	0.90
4000	0.87
5000	0.84
6000	0.81
7000	0.78

HEATING CAPACITY CORRECTION FACTORS (AT VARIOUS WATER & AIR ENTERING TEMPERATURES)											
Entering Air °F	Entering Water Temperatures °F										
	100°	110°	120°	130°	140°	150°	160°	170°	180°	190°	200°
50°	.455	.545	.635	.727	.818	.909	1.000	1.091	1.182	1.273	1.364
55°	.409	.500	.591	.682	.773	.864	.955	1.045	1.136	1.227	1.318
60°	.363	.455	.545	.636	.727	.818	.909	1.000	1.091	1.182	1.273
65°	.318	.409	.500	.691	.682	.773	.864	.955	1.045	1.136	1.227
70°	.272	.363	.455	.545	.636	.727	.818	.909	1.000	1.091	1.182
75°	.227	.318	.409	.500	.691	.662	.773	.864	.955	1.045	1.136
80°	.182	.272	.363	.455	.545	.636	.727	.818	.909	1.000	1.091

# MFH-W Series Fan Coil Units Hot Water Reheat Capacity

SIZE	COIL ROWS	GPM	H <sub>2</sub> O PD (TL)	REHEAT CAPACITY (MBH)@CFM			
				PRIMARY CFM @ HEATING			
				100	150	200	250
<b>300</b>	<b>1</b>	S.P. DROP		.01	.02	.04	.06
		0.5	.09	4.0	4.8	5.5	5.9
		1.0	.30	4.7	5.7	6.3	7.0
		1.5	.50	5.0	6.0	6.7	7.4
		2.0	1.0	5.1	6.2	7.0	7.7
		3.0	2.0	5.2	6.3	7.2	8.0
		4.0	3.0	5.3	6.4	7.3	8.2
	5.0	5.0	5.3	6.5	7.4	8.3	
	<b>2</b>	S.P. DROP		.02	.04	.08	.12
		0.5	.02	6.4	7.8	8.7	9.3
		1.0	.09	7.4	9.2	10.8	11.7
		1.5	.15	7.8	9.8	11.2	12.5
		2.0	.30	8.0	10.3	12.0	13.3
		3.0	.60	8.1	10.7	12.4	13.9
4.0		1.0	8.2	10.9	12.8	14.5	
5.0	1.5	8.3	11.1	13.1	14.8		

SIZE	COIL ROWS	GPM	H <sub>2</sub> O PD (TL)	REHEAT CAPACITY (MBH)@CFM			
				PRIMARY CFM @ HEATING			
				300	350	400	450
<b>500</b>	<b>1</b>	S.P. DROP		0.016	0.021	0.026	0.033
		0.5	0.2	9.8	10.3	10.7	11.1
		1.0	0.6	11.8	12.6	13.3	13.9
		1.5	1.3	12.7	13.6	14.4	15.2
		2.0	2.1	13.2	14.2	15.1	15.9
		3.0	4.3	13.8	14.9	15.8	16.7
		4.0	7.1	14.1	15.2	16.2	17.1
	5.0	10.4	14.3	15.4	16.5	17.4	
	<b>2</b>	S.P. DROP		0.032	0.042	0.053	0.065
		0.5	0.1	14.2	14.9	15.6	16.1
		1.0	0.2	18.2	19.6	20.7	21.7
		1.5	0.5	20.1	21.7	23.2	24.5
		2.0	0.8	21.1	23.0	24.7	26.2
		3.0	1.7	22.3	24.5	26.4	28.1
4.0		2.8	23.0	25.3	27.3	29.2	
5.0	4.1	23.4	25.8	27.9	29.9		

SIZE	COIL ROWS	GPM	H <sub>2</sub> O PD (TL)	REHEAT CAPACITY (MBH)@CFM			
				PRIMARY CFM @ HEATING			
				500	600	700	800
<b>750</b>	<b>1</b>	S.P. DROP		0.025	0.034	0.045	0.057
		0.5	0.2	12.7	13.3	13.8	14.2
		1.0	0.8	16.2	17.3	18.2	19.0
		1.5	1.7	17.9	19.2	20.3	21.3
		2.0	2.8	18.8	20.3	21.6	22.7
		3.0	5.6	19.8	21.5	23.0	24.3
		4.0	9.3	20.4	22.2	23.8	25.2
	5.0	13.7	20.8	22.6	24.3	25.7	
	<b>2</b>	S.P. DROP		.049	.068	.090	.114
		0.5	0.1	17.8	18.6	19.2	19.7
		1.0	0.2	24.7	26.5	27.9	29.1
		1.5	0.5	28.2	30.5	32.5	34.2
		2.0	0.8	30.3	33.0	35.4	37.4
		3.0	1.7	32.7	36.9	38.8	41.3
4.0		2.8	34.0	37.6	40.7	43.5	
5.0	4.1	34.9	38.7	42.0	45.0		

SIZE	COIL ROWS	GPM	H <sub>2</sub> O PD (TL)	REHEAT CAPACITY (MBH)@CFM				
				PRIMARY CFM @ HEATING				
				1200	1300	1400	1500	1600
<b>1500</b>	<b>1</b>	S.P. DROP		0.079	0.091	0.104	0.118	0.132
		0.5	0.3	16.6	16.9	17.1	17.2	17.4
		1.0	1.0	23.5	24.0	24.5	24.9	25.3
		1.5	1.9	27.1	27.8	28.4	29.0	29.6
		2.0	3.2	29.3	30.1	30.8	31.5	32.3
		3.0	6.5	31.8	32.8	33.7	34.5	35.3
		4.0	10.8	33.2	34.3	35.3	36.2	37.1
	5.0	16.0	34.2	35.3	36.4	37.4	38.3	
	<b>2</b>	S.P. DROP		0.159	0.183	0.209	0.263	0.265
		1.0	0.3	34.8	35.4	36.0	36.5	37.0
		1.5	0.6	42.4	43.4	44.4	45.2	46.0
		2.0	1.0	47.4	48.8	50.0	51.1	52.2
		4.0	3.2	57.4	59.4	61.3	63.0	64.7
		6.0	6.5	61.6	63.9	66.2	68.2	70.2
8.0		10.8	64.0	66.5	68.9	71.2	73.3	
10.0	16.0	65.5	68.1	70.7	73.1	75.3		

# MFH-W Series Fan Coil Units Hot Water Reheat Capacity

SIZE	COIL ROWS	GPM	H <sub>2</sub> O PD (TL)	REHEAT CAPACITY (MBH)@CFM				
				PRIMARY CFM @ HEATING				
				1500	1600	1700	1800	1900
<b>1800</b>	<b>1</b>	S.P. DROP		0.086	0.096	0.107	0.118	0.130
		1.0	1.1	26.7	27.2	27.6	27.9	28.3
		1.5	2.2	31.4	32.0	32.6	33.1	33.6
		2.0	3.7	34.3	35.0	35.7	36.4	37.0
		2.5	5.4	36.3	37.1	37.9	38.6	39.3
		3.0	7.5	37.7	38.6	39.5	40.3	41.0
		4.0	12.4	40	40.7	41.6	42.5	43.4
		5.0	18.3	41.0	42.0	43.1	44.0	44.9
	<b>2</b>	S.P. DROP		0.171	0.192	0.214	0.237	0.261
		1.0	0.3	38.4	38.9	39.3	39.7	40.1
		1.5	0.7	48.0	48.8	49.6	50.3	51.0
		2.0	1.1	54.5	55.7	56.7	57.7	58.6
		4.0	3.7	67.8	69.7	71.4	73.0	74.6
		6.0	7.5	73.3	75.8	77.9	79.9	81.8
		8.0	12.4	76.9	79.3	81.6	83.8	85.9
		10.0	18.3	79.0	81.6	84.0	86.3	88.5

SIZE	COIL ROWS	GPM	H <sub>2</sub> O PD (TL)	REHEAT CAPACITY (MBH)@CFM			
				PRIMARY CFM @ HEATING			
				1800	1900	2000	2100
<b>2000</b>	<b>1</b>	S.P. DROP		0.118	0.130	0.143	0.156
		1.0	1.1	27.9	28.3	28.6	28.9
		1.5	2.2	33.1	33.6	34.1	34.5
		2.0	3.7	36.4	37.0	37.6	38.1
		2.5	5.4	38.6	39.9	40.0	40.6
		3.0	7.5	40.3	41.0	41.8	42.4
		4.0	12.4	42.5	43.4	44.2	45.0
		5.0	18.3	44.0	44.9	45.8	46.7
	<b>2</b>	S.P. DROP		0.237	0.261	0.286	0.312
		1.0	0.3	39.7	40.1	40.4	40.8
		1.5	0.7	50.3	51.0	51.6	52.2
		2.0	1.1	57.7	58.6	59.5	60.3
		4.0	3.7	73.0	74.6	76.0	77.4
		6.0	7.5	79.9	81.8	83.5	85.3
		8.0	12.4	83.8	85.9	87.8	89.7
		10.0	18.3	86.3	88.5	90.6	92.7

SIZE	COIL ROWS	GPM	H <sub>2</sub> O PD (TL)	REHEAT CAPACITY (MBH)@CFM				
				PRIMARY CFM @ HEATING				
				2000	2200	2400	2600	3000
<b>3000</b>	<b>1</b>	S.P. DROP		0.05	0.06	0.07	0.09	0.11
		1.0	0.3	32.6	33.1	33.9	34.1	35.1
		1.5	0.5	40.2	41.3	42.0	43.1	44.1
		2.0	0.9	45.5	46.8	48.0	49.2	50.8
		2.5	1.5	48.2	50.3	51.8	53.2	54.9
		3.0	2.0	52.0	53.8	55.5	57.2	59.1
		4.0	3.0	55.3	57.9	59.1	60.9	63.1
		5.0	4.5	58.5	60.8	62.9	64.8	68.0
	<b>2</b>	S.P. DROP		0.10	0.12	0.14	0.18	0.22
		1.0	0.2	44.0	44.5	45.8	46.2	47.1
		1.5	0.3	53.9	56.1	56.9	59.7	61.2
		2.0	0.5	63.8	67.6	68.5	72.4	75.7
		4.0	1.2	91.6	94.1	97.4	101.2	104.2
		6.0	3.0	102.4	107.2	110.1	114.6	121.3
		8.0	7.0	108.6	113.9	118.7	122.8	130.4
		10.0	10.0	112.2	118.6	123.1	128.0	136.0

SIZE	COIL ROWS	GPM	H <sub>2</sub> O PD (TL)	REHEAT CAPACITY (MBH)@CFM				
				PRIMARY CFM @ HEATING				
				2500	2900	3100	3500	3900
<b>4000</b>	<b>1</b>	S.P. DROP		0.06	0.075	0.09	0.11	0.14
		1.0	0.3	35.5	36.6	36.9	37.6	38.0
		1.5	0.6	45.1	46.8	47.4	48.2	49.0
		2.0	1.0	52.0	54.0	54.8	56.1	57.8
		3.0	2.0	60.4	63.2	64.4	66.8	68.3
		4.0	3.4	64.7	68.1	69.7	72.2	74.2
		5.0	5.0	69.1	72.9	74.4	76.0	80.2
		7.0	9.0	74.0	78.0	80.0	82.0	87.0
	<b>2</b>	S.P. DROP		0.11	0.15	0.185	0.21	0.265
		1.0	0.2	46.2	46.8	47.2	48.1	49.0
		3.0	1.5	93.5	96.8	100.0	103.2	105.8
		5.0	3.2	113.9	115.0	12.1	128.0	123.7
		6.0	4.5	120.0	123.0	131.6	137.1	143.0
		8.0	7.5	129.1	130.0	141.8	148.9	155.0
		10.0	12.0	135.0	139.0	147.6	156.2	163.8
		12.0	16.5	138.2	143.0	154.1	162.1	170.2

<i>Model</i>	<i>Page</i>	<i>Model</i>	<i>Page</i>	<i>Model</i>	<i>Page</i>	<i>Model</i>	<i>Page</i>
2605	20	91120	56	222-A30-TH-277V	68	30R	34
2607	20	93108	58	222-A30-TH-480V	68	30R2	34
2610	20	93120	58	222-A30-THSS-208V	68	30R7	34
2615	20	316422	76	222-A30-THSS-240V	68	30R8	34
2620	20	880435	76	222-A30-THSS-277V	68	32T1	46
2625	20	880435	76	222-A30-THSS-480V	68	32T2	46
2630	20	880442	76	222-A60-TH-208V	68	3310EX33R	45
2640	20	880459	76	222-A60-TH-240V	68	3310EX33WR	45
2650	20	880466	76	222-A60-TH-277V	68	3320EX16	40
8510	28	880466	76	222-A60-TH-480V	68	3320EX33	40
8512	28	880497	76	222-A60-THSS-208V	68	3380EX33	34
8513	28	880497	76	222-A60-THSS-240V	68	342-30-TH-208V	68
8514	28	880510	76	222-A60-THSS-277V	68	342-30-TH-240V	68
8515	28	880527	76	222-A60-THSS-480V	68	342-30-TH-480V	68
8516	28	31939009	69	223-30-TH-208V	69	342-30-THSS-208V	68
8517	28	31940009	69	223-30-TH-240V	69	342-30-THSS-240V	68
8518	28	31941009	69	223-30-TH-277V	69	342-30-THSS-480V	68
8519	28	A1560	80	223-30-TH-480V	69	342-60-TH-208V	68
8520	28	DBTS IECR	62	223-30-THSS-208V	69	342-60-TH-240V	68
8522	28	170-TS	79	223-30-THSS-240V	69	342-60-TH-480V	68
8523	28	178 TMC	79	223-30-THSS-277V	69	342-60-THSS-208V	68
8524	28	188 TASA	79	223-30-THSS-480V	69	342-60-THSS-240V	68
8525	28	18D-2-30CF	74	223-60-TH-208V	69	342-60-THSS-480V	68
8526	28	18D-2-80CF	74	223-60-TH-240V	69	342-90-TH-208V	68
8527	28	198 TMC	79	223-60-TH-277V	69	342-90-TH-240V	68
8528	28	222-30-TH-208V	68	223-60-TH-480V	69	342-90-TH-480V	68
8529	28	222-30-TH-240V	68	223-60-THSS-208V	69	342-90-THSS-208V	68
8530	28	222-30-TH-277V	68	223-60-THSS-240V	69	342-90-THSS-240V	68
8532	28	222-30-TH-480V	68	223-60-THSS-277V	69	342-90-THSS-480V	68
8533	28	222-30-THSS-208V	68	223-60-THSS-480V	69	342-A30-TH-208V	68
8534	28	222-30-THSS-240V	68	223-90-TH-208V	69	342-A30-TH-240V	68
8535	28	222-30-THSS-277V	68	223-90-TH-240V	69	342-A30-TH-480V	68
8536	28	222-30-THSS-480V	68	223-90-TH-277V	69	342-A30-THSS-208V	68
8537	28	222-60-TH-208V	68	223-90-TH-480V	69	342-A30-THSS-240V	68
8538	28	222-60-TH-240V	68	223-90-THSS-208V	69	342-A30-THSS-480V	68
8539	28	222-60-TH-277V	68	223-90-THSS-240V	69	342-A60-TH-208V	68
9128	56	222-60-TH-480V	68	223-90-THSS-277V	69	342-A60-TH-240V	68
9136	56	222-60-THSS-208V	68	223-90-THSS-480V	69	342-A60-TH-480V	68
9148	56	222-60-THSS-240V	68	24A01G-3	87	342-A60-THSS-208V	68
9160	56	222-60-THSS-277V	68	24A05A-1	87	342-A60-THSS-240V	68
9172	56	222-60-THSS-480V	68	24A05E-1	87	342-A60-THSS-480V	68
9184	56	222-90-TH-208V	68	24A06G-1	87	343-30-TH-208V	69
9196	56	222-90-TH-240V	68	303EX16RW	34	343-30-TH-240V	69
9328	58	222-90-TH-277V	68	303EX16RW	46	343-30-TH-480V	69
9336	58	222-90-TH-480V	68	303EX32RW	34	343-30-THSS-208V	69
9348	58	222-90-THSS-208V	68	303EX32RW	46	343-30-THSS-240V	69
9360	58	222-90-THSS-240V	68	303EX8RW	34	343-30-THSS-480V	69
9372	58	222-90-THSS-277V	68	303EX8RW	46	343-60-TH-208V	69
9384	58	222-90-THSS-480V	68	305EX16	39	343-60-TH-240V	69
9396	58	222-A30-TH-208V	68	305EX32	39	343-60-TH-480V	69
91108	56	222-A30-TH-240V	68	305EX8	39	343-60-THSS-208V	69



# Product Index Listing

Model	Page	Model	Page	Model	Page	Model	Page
343-60-THSS-240V	69	4300EX8	47	630-25279	73	671-5018	73
343-60-THSS-480V	69	4300EX8W	47	630-25489	73	671-5056	73
343-90-TH-208V	69	4300EX8W	48	630-36489	73	671-5057	73
343-90-TH-240V	69	4300P	47	630-38579	73	671-5058	73
343-90-TH-480V	69	4300PB	40	631-16249	73	671-5059	73
343-90-THSS-208V	69	4300PW	47	631-25489	73	671-5060	73
343-90-THSS-240V	69	4300PW	48	631-25609	73	671-5061	73
343-90-THSS-480V	69	43T	47	631-38579	73	7PD2-812-1	97
3900AC	51	43T	48	632-1620	69	7PD3.5-812-1	97
3900ACC	51	43T2	47	632-1620	73	7PD5-812-1	97
3900-CS	51	4400EX16	40	632-1624	69	8PD10-1018-3	97
3900-CSC	51	4400EX32	40	632-1624	73	8PD15-1218-2-3	97
3900DS	51	4400EX8	40	632-2548	69	8PD15-1218-3	97
3900DSC	51	462-30-TH-480V	68	632-2548	73	8PD20-1220-3	97
3900-ICS	51	462-30-THSS-480V	68	6333D052033B30D0F	25	8PD25-1620-3	97
3900-ICSC	51	462-60-TH-480V	68	6333D052433B30D0F	25	8PD30-1624-2-3	97
3900-OCS	51	462-60-THSS-480V	68	6333D053834B30D0F1	25	8PD30-1624-3	97
3900-OCSC	51	462-90-TH-480V	68	6333D054134B30D0F1	25	8PD35-1624-3	97
3900REC	51	462-90-THSS-480V	68	6333D054833B30D0F	25	8PD40-1624-3	97
3900RECC	51	462-A30-TH-480V	68	6333D103834B30D0F1	25	8PD45-1630-3	97
3900T1	51	462-A30-THSS-480V	68	6333D104134B30D0F1	25	8PD50-1630-3	97
3900T1C	51	462-A60-TH-480V	68	6346D102033B30D0F	25	8PD5-812-3	97
3900T2	51	462-A60-THSS-480V	68	6346D102433B30D0F	25	9100EC	56
3900T2C	51	463-30-TH-480V	69	6346D104833B30D0F	25	9100IC	56
3900WW120	51	463-30-THSS-480V	69	641-35611	73	9100OC	56
3900WW28	51	463-60-TH-480V	69	641-35621	73	91BS012	56
3900WW36	51	463-60-THSS-480V	69	641-35631	73	91BS024	56
3900WW48	51	463-90-TH-480V	69	641-35641	73	91BS036	56
3900WW60	51	463-90-THSS-480V	69	641-35661	73	91BS048	56
3900WW72	51	483 TM	79	641-36051	73	91BS060	56
3900WW96	51	48T2	48	641-36061	73	91BS072	56
39BS120	51	4PD10-1018-3	97	641-36071	73	91BS084	56
39BS120C	51	4PD15-1218-2-3	97	641-37211	73	91BS096	56
39BS28	51	4PD15-1218-3	97	641-50011	73	91BS108	56
39BS28C	51	4PD20-1220-3	97	641-50021	73	91BS120	56
39BS36	51	4PD25-1620-3	97	641-70001	73	9300EC	58
39BS36C	51	4PD30-1624-2-3	97	641-70011	73	9300IC	58
39BS48	51	4PD30-1624-3-3	97	641-70021	73	9300OC	58
39BS48C	51	4PD35-1624-3	97	641-70031	73	93BS012	58
39BS60	51	4PD40-1624-3	97	641-70041	73	93BS024	58
39BS60C	51	4PD50-1630-3	97	641-70241	73	93BS036	58
39BS72	51	4PD5-812-3	97	641-70251	73	93BS048	58
39BS72C	51	630-05129	73	641-70261	73	93BS060	58
39BS96	51	630-10209	73	641-70271	73	93BS072	58
39BS96C	51	630-10249	73	641-70281	73	93BS084	58
4300EX16	47	630-16209	73	641-70321	73	93BS096	58
4300EX16W	47	630-16249	73	671-3454	73	93BS108	58
4300EX16W	48	630-16279	73	671-3492	73	93BS120	58
4300EX32	47	630-16489	73	671-3784	73	A1600	22
4300EX32W	47	630-25209	73	671-3785	73	A1601	22
4300EX32W	48	630-25249	73	671-3786	73	A5105	15

<i>Model</i>	<i>Page</i>	<i>Model</i>	<i>Page</i>	<i>Model</i>	<i>Page</i>	<i>Model</i>	<i>Page</i>
A51100	18	B5150	15	CB-300BS	63	CSW	55
A5120	15	B5175	18	CB-4	63	CTBDB	55
A5150	15	BBS024A	55	CB-400BS	63	CTBDB	55
A5175	18	BBS024AW	55	CB-5	63	CTBDB-TP	55
A5520/UHB	10	BBS024C	55	CB-500BS	63	CTBDW	55
A6176	17	BBS028A	55	CB-6	63	CTBSB	55
A6176	86	BBS028AW	55	CB-600BS	63	CTBSB	55
AD5120	15	BBS028C	55	CB-7	63	CTBSB-TP	55
AD5120	15	BBS036A	55	CB-700BS	63	CTBSW	55
AD5150	15	BBS036AW	55	CB-8	63	CV10012X	38
AD5150	15	BBS036C	55	CB-800BS	63	CV10022Xi	38
AD5175	15	BBS040A	55	CB-9	63	CV10027X	38
AET5DWS	83	BBS040AW	55	CB-900BS	63	CV100X	38
AET5SWS	83	BBS040C	55	CF36	82	CV100Xi	38
AF3401-24	36	BBS048A	55	CF48	82	CV100YX	38
AF3402-24	36	BBS048AW	55	CF60	82	CV11012X	38
AF3403-24	36	BBS048C	55	CFHD36	82	CV11022Xi	38
AG3401-24	36	BBS060A	55	CFHD48	82	CV11027X	38
AG3402-24	36	BBS060AW	55	CFHD60	82	CV110X	38
AG3403-24	36	BBS060C	55	CH-2212-1C	77	CV110Xi	38
AH3401-24	36	BBS072A	55	CH-6424-1C	77	CV110YX	38
AH3402-24	36	BBS072AW	55	CHWG-222	69	CV12512X	38
AH3403-24	36	BBS072C	55	CHWG-223	69	CV12522Xi	38
APS-3C	74	BBS084A	55	CHWG-342	69	CV12527X	38
ASHDB ECL	63	BBS084AW	55	CHWG-343	69	CV125X	38
ASHDB ECR	63	BBS084C	55	CHWG-462	69	CV125Xi	38
ASHDB IC	63	BBS096A	55	CHWG-463	69	CV125YX	38
ASHDB OC	63	BBS096AW	55	CIT-1	74	CV4512X	38
ASHDB SP	63	BBS096C	55	CKTD110	84	CV4522Xi	38
ASHDB WT	63	BBS120A	55	CP122	37	CV4527X	38
ASHDB-10	63	BBS120AW	55	CP122i	37	CV45X	38
ASHDB-2	63	BBS120C	55	CP123	37	CV45Xi	38
ASHDB-3	63	BDR115	55	CP123i	37	CV45YX	38
ASHDB-4	63	BDR115B	55	CP125	37	CV6012X	38
ASHDB-5	63	BDR115W	55	CP125i	37	CV6022Xi	38
ASHDB-6	63	BOX 3310	40	CP127	37	CV6027X	38
ASHDB-7	63	BOX3310	34	CP127i	37	CV60X	38
ASHDB-8	63	BOX3310	45	CP2202i	37	CV60Xi	38
ASHDB-8/20-1000BS	63	CB ECL	63	CP2203i	37	CV60YX	38
ASHDB-8/20-100BS	63	CB ECR	63	CP2205i	37	CV7512X	38
ASHDB-8/20-200BS	63	CB IC	63	CP2207i	37	CV7522Xi	38
ASHDB-8/20-300BS	63	CB MF	63	CP702	37	CV7527X	38
ASHDB-8/20-400BS	63	CB OC	63	CP703	37	CV75X	38
ASHDB-8/20-500BS	63	CB SP	63	CP705	37	CV75Xi	38
ASHDB-8/20-600BS	63	CB WT	63	CP707	37	CV75YX	38
ASHDB-8/20-700BS	63	CB-10	63	CP802	37	CV9012X	38
ASHDB-8/20-800BS	63	CB-1000BS	63	CP803	37	CV9022Xi	38
ASHDB-8/20-900BS	63	CB-100BS	63	CP805	37	CV9027X	38
ASHDB-9	63	CB-2	63	CP807	37	CV90X	38
B5105	15	CB-200BS	63	CS	55	CV90Xi	38
B51100	18	CB-3	63	CSB	55	CV90YX	38

# Product Index Listing

Model	Page	Model	Page	Model	Page	Model	Page
CVB42X	38	DBF/DBT-300BS	61	DCS403	13	E3058T2DWB	39
CVB60X	38	DBF/DBT-400BS	61	DCS403 / 5100	17	E3058TDWB	39
CVB84X	38	DBF/DBT-500BS	61	DCS603 / 5100	17	E3210RPW	46
CVCBX	38	DBF/DBT-600BS	61	DCS803	13	E3210TRPW	46
CVSP	38	DBF/DBT-700BS	61	DC-SK-1	64	E3215RPW	46
D1600	20	DBF/DBT-800BS	61	DC-SK-1	76	E3215TRPW	46
D1600	22	DBF/DBT-900BS	61	DCS-MT303	23	E3275RPW	46
D1602	20	DBF-10/DBT-10	61	DCS-MT303	22	E3275TRPW	46
D1602	22	DBF-2/DBT-2	61	DR115	55	E3312RP	44
D1603	20	DBF-3/DBT-3	61	DR115B	55	E3312RPW	44
D1603	22	DBF-4/DBT-4	61	DR115W	55	E3312T2RP	44
D1610	20	DBF-5/DBT-5	61	DS	55	E3312T2RPW	44
D1610	22	DBF-6/DBT-6	61	DS5105	15	E3312T2SRP	45
D1612	20	DBF-7/DBT-7	61	DS51100	18	E3312T2SRPW	45
D1612	22	DBF-8/DBT-8	61	DS5120	15	E3312TRP	44
D1613	20	DBF-9/DBT-9	61	DS5150	15	E3312TRPW	44
D1613	22	DBTS ECL	62	DS5175	18	E3312TSRP	45
D2022H10BA	83	DBTS ECR	62	DSB	55	E3312TSRPW	45
D2022H10BB	83	DBTS IC	62	DSW	55	E3313RP	44
D2025H10DA	83	DBTS IECL	62	E2903-024C	54	E3313RPW	44
DBCT/DBCF ECL	61	DBTS MF	62	E2903-024HAW	52	E3313T2RP	44
DBCT/DBCF ECR	61	DBTS OC	62	E2903-024S	53	E3313T2RPW	44
DBCT/DBCF IC	61	DBTS SP	62	E2903-024SW	53	E3313T2SRP	45
DBCT/DBCF IECL	61	DBTS WT	62	E2905-028C	54	E3313T2SRPW	45
DBCT/DBCF IECR	61	DBTS-10	62	E2905-028HAW	52	E3313TRP	44
DBCT/DBCF IF	61	DBTS-1000BS	62	E2905-028S	53	E3313TRPW	44
DBCT/DBCF OC	61	DBTS-100BS	62	E2905-028SW	53	E3313TSRP	45
DBCT/DBCF SP	61	DBTS-2	62	E2906-036C	54	E3313TSRPW	45
DBCT/DBCF WT	61	DBTS-200BS	62	E2906-036HAW	52	E3321TD-RP	40
DBCT/DBCF-1000BS	61	DBTS-3	62	E2906-036S	53	E3322TD-RP	40
DBCT/DBCF-100BS	61	DBTS-300BS	62	E2906-036SW	53	E3323TD-RP	40
DBCT/DBCF-200BS	61	DBTS-4	62	E2907-040C	54	E3383D-RP	34
DBCT/DBCF-300BS	61	DBTS-400BS	62	E2907-040HAW	52	E3703-024	50
DBCT/DBCF-400BS	61	DBTS-5	62	E2907-040S	53	E3703-024B	50
DBCT/DBCF-500BS	61	DBTS-500BS	62	E2907-040SW	53	E3705-028	50
DBCT/DBCF-600BS	61	DBTS-6	62	E2910-048C	54	E3705-028B	50
DBCT/DBCF-700BS	61	DBTS-600BS	62	E2910-048HAW	52	E3706-036	50
DBCT/DBCF-800BS	61	DBTS-7	62	E2910-048S	53	E3706-036B	50
DBCT/DBCF-900BS	61	DBTS-700BS	62	E2910-048SW	53	E3707-040	50
DBCT-10/DBCF-10	61	DBTS-8	62	E2912-060C	54	E3707-040B	50
DBCT-2/DBCF-2	61	DBTS-800BS	62	E2912-060HAW	52	E3710-048	50
DBCT-3/DBCF-3	61	DBTS-9	62	E2912-060S	53	E3710-048B	50
DBCT-4/DBCF-4	61	DBTS-900BS	62	E2912-060SW	53	E3712-060	50
DBCT-5/DBCF-5	61	DC-33	25	E2915-072C	54	E3712-060B	50
DBCT-6/DBCF-6	61	DC-46	25	E2915-072HAW	52	E3715-072	50
DBCT-7/DBCF-7	61	DC-66	25	E2915-072S	53	E3715-072B	50
DBCT-8/DBCF-8	61	DC-79	25	E2915-072SW	53	E3904-28	49
DBCT-9/DBCF-9	61	DCS1003	13	E3035DWBW	34	E3904-28C	49
DBF/DBT-1000BS	61	DCS1003 / 5100	17	E3038DWBW	34	E3906-36	49
DBF/DBT-100BS	61	DCS202 / 5100	17	E3055T2DWB	39	E3906-36C	49
DBF/DBT-200BS	61	DCS303	13	E3055TDWB	39	E3910-48	49

Model	Page	Model	Page	Model	Page	Model	Page
E3910-48C	49	ET5SRTS	83	F2910-048SW	53	F3317T2SRPW	45
E3912-60	49	ET5SS	17	F2912-060C	54	F3317TRP	44
E3912-60C	49	ET5SS	83	F2912-060HAW	52	F3317TRPW	44
E3915-72	49	ET5STS	83	F2912-060S	53	F3317TSRP	45
E3915-72C	49	ET5SWS	83	F2912-060SW	53	F3317TSRPW	45
E4310RP	47	ETD5MS	83	F2915-072C	54	F3326TD-RP	40
E4310RPW	47	ETD5MTS	83	F2915-072HAW	52	F3327TD-RP	40
E4310TRP	47	ETD5SS	83	F2915-072S	53	F3386D-RP	34
E4310TRPW	47	ETD5STS	83	F2915-072SW	53	F3387D-RP	34
E4315RP	47	F1F2605CA1	21	F2917-084C	54	F3422T	41
E4315RPW	47	F1F2607CA1	21	F2917-084S	53	F3423T	41
E4315TRP	47	F1F2610CA1	21	F2917-084SW	53	F3424T	41
E4315TRPW	47	F1F5103N	16	F2920-096C	54	F3425T	41
E4375RP	47	F1F5103N	17	F2920-096HAW	52	F3452T	41
E4375RPW	47	F1F5105N	16	F2920-096S	53	F3453T	41
E4375TRP	47	F1F5105N	17	F2920-096SW	53	F3454T	41
E4375TRPW	47	F1F5503T	11	F2925-120C	54	F3455T	41
E4410TRP	40	F1F5505T	11	F2925-120HAW	52	F3472	36
E4415TRP	40	F1F5507T	11	F2925-120S	53	F3473	36
E4475TRP	40	F1F5510T	11	F2925-120SW	53	F3474	36
E4810RPW	48	F1F5515T	11	F2F5103N	16	F3475	36
E4810TRPW	48	F1FUH03003	13	F2F5103N	17	F3482	35
E4815RPW	48	F1FUH05003	13	F2F5105N	16	F3483	35
E4815TRPW	48	F1FUH07CA1	13	F2F5105N	17	F3484	35
E4875RPW	48	F1FUH10CA1	13	F2F5107CA1L	16	F3485	35
E4875TRPW	48	F1FUH12C03	13	F2F5107CA1L	17	F3703-024	50
E8801050	30	F1FUH15C03	13	F2F5110CA1L	16	F3703-024B	50
E8802075	30	F1FUH20CA1	13	F2F5110CA1L	17	F3705-028	50
E8803100	30	F1FUH25CA1	13	F2FUH05C03	13	F3705-028B	50
E8804125	30	F1G7203	93	F2FUH10C03	13	F3706-036	50
E8805150	30	F1G7205	93	F30522T2DWB	39	F3706-036B	50
E8806200	30	F1G7305	95	F30522TDWB	39	F3707-040	50
EPETD8D	6	F2903-024C	54	F30522TDWB	39	F3707-040B	50
EPETD8D	9	F2903-024HAW	52	F3052TDWB	39	F3710-048	50
EPETD8D	83	F2903-024S	53	F3220RPW	46	F3710-048B	50
EPETD8S	6	F2903-024SW	53	F3220T2RPW	46	F3712-060	50
EPETD8S	9	F2905-028C	54	F3316RP	44	F3712-060B	50
EPETD8S	83	F2905-028HAW	52	F3316RPW	44	F3715-072	50
EPETP8D	6	F2905-028S	53	F3316T2RP	44	F3715-072B	50
EPETP8D	9	F2905-028SW	53	F3316T2RPW	44	F3717-084	50
EPETP8D	83	F2906-036C	54	F3316T2SRP	45	F3717-084B	50
EPETP8S	6	F2906-036HAW	52	F3316T2SRPW	45	F3720-096	50
EPETP8S	9	F2906-036S	53	F3316TRP	44	F3720-096B	50
EPETP8S	83	F2906-036SW	53	F3316TRPW	44	F3725-120	50
ET5D4S	83	F2907-040C	54	F3316TSRP	45	F3725-120B	50
ET5DS	83	F2907-040HAW	52	F3316TSRPW	45	F3904-28	49
ET5DTS	83	F2907-040S	53	F3317RP	44	F3904-28C	49
ET5DWS	83	F2907-040SW	53	F3317RPW	44	F3906-36	49
ET5MS	83	F2910-048C	54	F3317T2RP	44	F3906-36C	49
ET5S4S	83	F2910-048HAW	52	F3317T2RPW	44	F3910-48	49
ET5SRS	83	F2910-048S	53	F3317T2SRP	45	F3910-48C	49



# Product Index Listing

Model	Page	Model	Page	Model	Page	Model	Page
F3912-60	49	F3FUH25CA1	13	FEP-1724-3RA	9	FES-3060-3A	78
F3912-60C	49	F3FUH30CA1	13	FEP-1727-1RA	8	FES-4548-3	78
F3915-72	49	F3G7203	93	FEP-1748-1RA	8	FES-4560-3	78
F3915-72C	49	F3G7205	93	FEP-1748-3RA	9	FFH-512A	72
F3920-96	49	F3G7305	95	FEP-1812-1RA	8	FFH-912B	72
F3920-96C	49	F4320RP	47	FEP-1820-1RA	8	FH15	81
F3E7210	93	F4320RPW	47	FEP-1820-3RA	9	FHIT	81
F3E7210-2	93	F4320T2RP	47	FEP-1824-1RA	8	FHK-1	77
F3E7215	93	F4320T2RPW	47	FEP-1824-3RA	9	FHK-1324-3A	76
F3E7215-2	93	F4320TRP	47	FEP-1827-1RA	8	FHK-1348-3A	76
F3E7220-2	93	F4320TRPW	47	FEP-1848-1RA	8	FHK-212-1CA	76
F3E7223-2	93	F4420T2RP	40	FEP-1848-3RA	9	FHK-224-1A	76
F3E7310	95	F4420TRP	40	FEP-3420-1RA	8	FHK-248-1A	76
F3E7310-2	95	F4820RPW	48	FEP-3420-3RA	9	FHK-424-1A	76
F3E7312	95	F4820T2RPW	48	FEP-3424-1RA	8	FHK-448-1A	76
F3E7312-2	95	F4820TRPW	48	FEP-3424-3RA	9	FHK-624-3A	76
F3E7315	95	F8801050	30	FEP-3427-1RA	8	FHK-648-3A	76
F3E7315-2	95	F8802075	30	FEP-3448-1RA	8	FPC2110	75
F3F2605CA1	21	F8803100	30	FEP-3448-3RA	9	FPC2120	75
F3F2607CA1	21	F8804125	30	FEP-3457-1RA	8	FPC2140	75
F3F2610CA1	21	F8805150	30	FEP-3620-1RA	8	FPC2160	75
F3F2615CA1	21	F8806200	30	FEP-3620-3RA	9	FPC2210	75
F3F2625CA1	21	FAM33	25	FEP-3624-1RA	8	FPC2220	75
F3F2630CA1	21	FAM46	25	FEP-3624-3RA	9	FPC2240	75
F3F2640CA1	21	FAM66	25	FEP-3627-1RA	8	FPC2260	75
F3F2650CA1	21	FAM79	25	FEP-3648-1RA	8	FPC4110	75
F3F5115CA1L	16	FEC-30-120	74	FEP-3648-3RA	9	FPC4120	75
F3F5115CA1L	17	FEC-30-240	74	FEP-3657-1RA	8	FPC4140	75
F3F5125CA1L	16	FEC-60-120	74	FEP-3820-1RA	8	FPC4160	75
F3F5125CA1L	17	FEC-60-240	74	FEP-3820-3RA	9	FPC4210	75
F3F5130CA1L	16	FEP-0812-1RA	8	FEP-3824-1RA	8	FPC4220	75
F3F5130CA1L	17	FEP-0820-1RA	8	FEP-3824-3RA	9	FPC4240	75
F3F5140CA1L	16	FEP-0820-3RA	9	FEP-38271-RA	8	FPC4260	75
F3F5140CA1L	17	FEP-0824-1RA	8	FEP-3848-1RA	8	FPC7110	75
F3F5150CA1L	16	FEP-0824-3RA	9	FEP3848-3RA	9	FPC7120	75
F3F5150CA1L	17	FEP-0827-1RA	8	FEP-7620-1RA	8	FPC7140	75
F3F5160CA1	19	FEP-0848-1RA	8	FEP-7620-3RA	9	FPC7160	75
F3F5170CA1	19	FEP-0848-3RA	9	FEP-7624-1RA	8	FPC7210	75
F3F5503T	11	FEP-1612-1RA	8	FEP-7624-3RA	9	FPC7220	75
F3F5505T	11	FEP-1620-1RA	8	FEP-7627-1RA	8	FPC7240	75
F3F5507T	11	FEP-1620-3RA	9	FEP-7648-1RA	8	FPC7260	75
F3F5510T	11	FEP-1624-1RA	8	FEP-7648-3RA	9	FPC8110	75
F3F5515T	11	FEP-1624-3RA	9	FEP-7657-1RA	8	FPC8120	75
F3F5520T	11	FEP-1627-1RA	8	FES-0924-1C	78	FPC8140	75
F3F5525T	11	FEP-1648-1RA	8	FES-1024-1CA	78	FPC8160	75
F3F5530T	11	FEP-1648-3RA	9	FES-1520-3A	78	FPC8210	75
F3FUH03C03	13	FEP-1657-1RA	8	FES-1524-1A	78	FPC8220	75
F3FUH07C03	13	FEP-1712-1RA	8	FES-1524-3E	78	FPC8240	75
F3FUH12C03	13	FEP-1720-1RA	8	FES-1548-3E	78	FPC8260	75
F3FUH15C03	13	FEP-1720-3RA	9	FES-1560-3A	78	FS5101	17
F3FUH20CA1	13	FEP-1724-1RA	8	FES-3048-3A	78	FS5101	19

<i>Model</i>	<i>Page</i>	<i>Model</i>	<i>Page</i>	<i>Model</i>	<i>Page</i>	<i>Model</i>	<i>Page</i>
FS5102	17	G2910-048C	54	G3315TRP	44	G3709-060B	50
FS5102	19	G2910-048HAW	52	G3315TRPW	44	G3710-048	50
FSW5111	17	G2910-048S	53	G3316RP	44	G3710-048B	50
FSW5112	17	G2910-048SW	53	G3316RPW	44	G3711-072	50
FSW5112	22	G2911-072C	54	G3316T2RP	44	G3711-072B	50
G1G2605CA1	21	G2911-072HAW	52	G3316T2RPW	44	G3712-060	50
G1G2607CA1	21	G2911-072S	53	G3316TRP	44	G3712-060B	50
G1G2610CA1	21	G2911-072SW	53	G3316TRPW	44	G3713-084	50
G1G5103N	16	G2912-060C	54	G3317RP	44	G3713-084B	50
G1G5103N	17	G2912-060HAW	52	G3317RPW	44	G3715-072	50
G1G5105N	16	G2912-060S	53	G3317T2RP	44	G3715-072B	50
G1G5105N	17	G2912-060SW	53	G3317T2RPW	44	G3715-096	50
G1G5107CA1L	16	G2913-084C	54	G3317TRP	44	G3715-096B	50
G1G5107CA1L	17	G2913-084S	53	G3317TRPW	44	G3717-084	50
G1G5110CA1N	16	G2913-084SW	53	G3323TD-RP	40	G3717-084B	50
G1G5110CA1N	17	G2915-072C	54	G3324TD-RP	40	G3718-120	50
G1G5503T	11	G2915-072HAW	52	G3325TD-RP	40	G3718-120B	50
G1G5505T	11	G2915-072S	53	G3326TD-RP	40	G3720-096	50
G1G5507T	11	G2915-072SW	53	G3327TD-RP	40	G3720-096B	50
G1G5510T	11	G2915-096C	54	G3383D-RP	34	G3725-120	50
G1G7203	93	G2915-096HAW	52	G3384D-RP	34	G3725-120B	50
G1G7205	93	G2915-096S	53	G3385D-RP	34	G3904-28	49
G1G7305	95	G2915-096SW	53	G3386D-RP	34	G3904-28C	49
G1GUH03003	13	G2917-084C	54	G3387D-RP	34	G3906-36	49
G1GUH05003	13	G2917-084S	53	G3422T	41	G3906-36C	49
G1GUH07CA1	13	G2917-084SW	53	G3423T	41	G3910-48	49
G1GUH10CA1	13	G2918-120C	54	G3424T	41	G3910-48C	49
G2903-024C	54	G2918-120HAW	52	G3425T	41	G3912-60	49
G2903-024HAW	52	G2918-120S	53	G3452T	41	G3912-60C	49
G2903-024S	53	G2918-120SW	53	G3453T	41	G3915-72	49
G2903-024SW	53	G2920-096C	54	G3454T	41	G3915-72C	49
G2905-028C	54	G2920-096HAW	52	G3455T	41	G3920-96	49
G2905-028HAW	52	G2920-096S	53	G3472	36	G3920-96C	49
G2905-028S	53	G2920-096SW	53	G3473	36	G8801050	30
G2905-028SW	53	G2925-120C	54	G3474	36	G8802075	30
G2906-036C	54	G2925-120HAW	52	G3475	36	G8803100	30
G2906-036HAW	52	G2925-120S	53	G3482	35	G8804125	30
G2906-036S	53	G2925-120SW	53	G3483	35	G8805150	30
G2906-036SW	53	G3032DWBW	34	G3484	35	G8806200	30
G2907-040C	54	G3052T2DWB	39	G3485	35	GF-SK-1	64
G2907-040HAW	52	G3052TDWB	39	G3703-024	50	GF-SK-1	76
G2907-040S	53	G3314RP	44	G3703-024B	50	H1D1AA	85
G2907-040SW	53	G3314RPW	44	G3705-028	50	H1G7203	93
G2907-048C	54	G3314T2RP	44	G3705-028B	50	H1G7205	93
G2907-048HAW	52	G3314T2RPW	44	G3706-036	50	H1G7305	95
G2907-048S	53	G3314TRP	44	G3706-036B	50	H1H2605CA1	21
G2907-048SW	53	G3314TRPW	44	G3707-040	50	H1H2607CA1	21
G2909-060C	54	G3315RP	44	G3707-040B	50	H1H2610CA1	21
G2909-060HAW	52	G3315RPW	44	G3707-048	50	H1H5503T	11
G2909-060S	53	G3315T2RP	44	G3707-048B	50	H1H5505T	11
G2909-060SW	53	G3315T2RPW	44	G3709-060	50	H1H5507T	11

# Product Index Listing

Model	Page	Model	Page	Model	Page	Model	Page
H1H5510T	11	H2915-072SW	53	H3482	35	H3G7315-2	95
H1H5515T	11	H2915-72AWi	52	H3483	35	H3H2605CA1	21
H1HUH03003	13	H2917-084C	54	H3484	35	H3H2607CA1	21
H1HUH05003	13	H2917-084CI	54	H3485	35	H3H2610CA1	21
H1HUH07CA1	13	H2917-084S	53	H3703-024	50	H3H2615CA1	21
H1HUH10CA1	13	H2917-084SW	53	H3703-024B	50	H3H2620CA1	21
H1HUH12C03	13	H2917-84AWi	52	H3705-028	50	H3H2625CA1	21
H1HUH15C03	13	H2920-096C	54	H3705-028B	50	H3H2630CA1	21
H1HUH20CA1	13	H2920-096CI	54	H3706-036	50	H3H2640CA1	21
H1HUH25CA1	13	H2920-096HAW	52	H3706-036B	50	H3H2650CA1	21
H1HUH30CA1	13	H2920-096S	53	H3707-040	50	H3H5503T	11
H2903-024C	54	H2920-096SW	53	H3707-040B	50	H3H5505T	11
H2903-024CI	54	H2920-120AWi	52	H3710-048	50	H3H5507T	11
H2903-024HAW	52	H2925-120C	54	H3710-048B	50	H3H5510T	11
H2903-024S	53	H2925-120CI	54	H3712-060	50	H3H5515T	11
H2903-024SW	53	H2925-120HAW	52	H3712-060B	50	H3H5520T	11
H2903-24AWi	52	H2925-120S	53	H3715-072	50	H3H5525T	11
H2905-028C	54	H2925-120SW	53	H3715-072B	50	H3H5530T	11
H2905-028CI	54	H2HUH05C03	13	H3717-084	50	H3H5605T	23
H2905-028HAW	52	H2HUH07C03	13	H3717-084B	50	H3H5705T	22
H2905-028S	53	H3032DWBW	34	H3720-096	50	H3HUH03C03	13
H2905-028SW	53	H30522T2DWB	39	H3720-096B	50	H3HUH12C03	13
H2905-28AWi	52	H30522TDWB	39	H3725-120	50	H3HUH15C03	13
H2906-036C	54	H3052T2DWB	39	H3725-120B	50	H3HUH20CA1	13
H2906-036C	54	H3052TDWB	39	H3904-28	49	H3HUH25CA1	13
H2906-036HAW	52	H3275RPW	46	H3904-28C	49	H3HUH30CA1	13
H2906-036S	53	H3275T2RPW	46	H3906-36	49	H46D1214	85
H2906-036SW	53	H3317RP	44	H3906-36C	49	H474 TMC	80
H2906-36AWi	52	H3317RPW	44	H3910-48	49	H5520/HMK	10
H2907-040C	54	H3317T2RP	44	H3910-48C	49	H5550/HMK	10
H2907-040C	54	H3317T2RPW	44	H3912-60	49	H8801050	30
H2907-040HAW	52	H3317T2SRP	45	H3912-60C	49	H8801050i	30
H2907-040S	53	H3317T2SRPW	45	H3915-72	49	H8802075	30
H2907-040SW	53	H3317TRP	44	H3915-72C	49	H8802075i	30
H2907-40AWi	52	H3317TRPW	44	H3920-96	49	H8803100	30
H2910-048C	54	H3317TSRP	45	H3920-96C	49	H8803100i	30
H2910-048CI	54	H3317TSRPW	45	H3G7203	93	H8804125	30
H2910-048HAW	52	H3327TD-RP	40	H3G7205	93	H8804125i	30
H2910-048S	53	H3387D-RP	34	H3G7210	93	H8805150	30
H2910-048SW	53	H3422T	41	H3G7210-2	93	H8805150i	30
H2910-48AWi	52	H3423T	41	H3G7215	93	H8806200	30
H2912-060C	54	H3424T	41	H3G7215-2	93	H8806200i	30
H2912-060C	54	H3425T	41	H3G7220-2	93	HF1B5103N	16
H2912-060HAW	52	H3452T	41	H3G7223-2	93	HF1B5103N	17
H2912-060S	53	H3453T	41	H3G7230-2	93	HF1B5105N	16
H2912-060SW	53	H3454T	41	H3G7305	95	HF1B5105N	17
H2912-60AWi	52	H3455T	41	H3G7310	95	HF2B5103N	16
H2915-072C	54	H3472	36	H3G7310-2	95	HF2B5103N	17
H2915-072CI	54	H3473	36	H3G7312	95	HF2B5105N	16
H2915-072HAW	52	H3474	36	H3G7312-2	95	HF2B5105N	17
H2915-072S	53	H3475	36	H3G7315	95	HF2B5107CA1L	16

Model	Page	Model	Page	Model	Page	Model	Page
HF2B5107CA1L	17	HF3B5150CA1L	17	HLA 12-208360-3.0-24	5	HP8-1440120-2T	91
HF2B5110CA1L	16	HF3B5160CA1	19	HLA 12-208360-5.0-24	5	HP8-1440120-2T	91
HF2B5110CA1L	17	HF3B5170CA1	19	HLA 12-208360-7.5-24	5	HP8-1440120-2TRP	92
HF2BUH10C03	13	HF3B5180CA1	19	HLA 12-240160-3.0-24	5	HP8C-12PK	91
HF3210RPW	46	HF3B5190CA1	19	HLA 12-240160-5.0-24	5	HP8H-12PK	91
HF3210T2RPW	46	HF4310RP	47	HLA 12-240160-7.5-24	5	ICH-240C	80
HF3215RPW	46	HF4310RPW	47	HLA 12-240360-3.0-24	5	J3422T	41
HF3215T2RPW	46	HF4310T2RP	47	HLA 12-240360-5.0-24	5	J3423T	41
HF3220RPW	46	HF4310T2RPW	47	HLA 12-240360-7.5-24	5	J3424T	41
HF3220T2RPW	46	HF4310TRP	47	HLA 12-480360-3.0-24	5	J3425T	41
HF3222RPW	46	HF4310TRPW	47	HLA 12-480360-5.0-24	5	J3452T	41
HF3222T2RPW	46	HF4315RP	47	HLA 12-480360-7.5-24	5	J3453T	41
HF3315RP	44	HF4315RPW	47	HLA 16-208360-10.0-24	5	J3454T	41
HF3315RPW	44	HF4315T2RP	47	HLA 16-240160-10.0-24	5	J3455T	41
HF3315T2RP	44	HF4315T2RPW	47	HLA 16-240360-10.0-24	5	J3472	36
HF3315T2RPW	44	HF4315TRP	47	HLA 16-480360-10.0-24	5	J3473	36
HF3315T2SRP	45	HF4315TRPW	47	HLA 20-208360-15.0-24	5	J3474	36
HF3315T2SRPW	45	HF4320RP	47	HLA 20-240360-15.0-24	5	J3475	36
HF3315TRP	44	HF4320RPW	47	HLA 20-480360-15.0-24	5	J3482	35
HF3315TRPW	44	HF4320T2RP	47	HLA 20-480360-20.0-24	5	J3483	35
HF3315TSRP	45	HF4320T2RPW	47	HLA 20-480360-25.0-24	5	J3484	35
HF3315TSRPW	45	HF4320TRP	47	HLA 20-600360-15.0-24	5	J3485	35
HF3316RP	44	HF4320TRPW	47	HLA 20-600360-20.0-24	5	JK	55
HF3316RPW	44	HF4375RP	47	HLA 20-600360-25.0-24	5	JKB	55
HF3316T2RP	44	HF4375RPW	47	HLHM	6	JKW	55
HF3316T2RPW	44	HF4375T2RP	47	HLP M10	6	K3422T	41
HF3316T2SRP	45	HF4375T2RPW	47	HLP M1525	6	K3423T	41
HF3316T2SRPW	45	HF4375TRP	47	HLP M37	6	K3424T	41
HF3316TRP	44	HF4375TRPW	47	HLT-1	6	K3425T	41
HF3316TRPW	44	HF4410T2RP	40	HLT-1	9	K3452T	41
HF3316TSRP	45	HF4415T2RP	40	HLT-1	83	K3453T	41
HF3316TSRPW	45	HF4420T2RP	40	HLT-2	6	K3454T	41
HF3323TD-RP	40	HF4475T2RP	40	HLT-2	9	K3455T	41
HF3324TD-RP	40	HF4810RPW	48	HLT-2	83	K3472	36
HF3325TD-RP	40	HF4810T2RPW	48	HLWM10	6	K3473	36
HF3326TD-RP	40	HF4815RPW	48	HLWM1525	6	K3474	36
HF3384D-RP	34	HF4815T2RPW	48	HLWM37	6	K3475	36
HF3385D-RP	34	HF4820RPW	48	HP-11-QT	77	K3482	35
HF3386D-RP	34	HF4820T2RPW	48	HP-5-QT	77	K3483	35
HF3B51100CA1	19	HF4875RPW	48	HP6-1000120-2CT	91	K3484	35
HF3B5115CA1L	16	HF4875T2RPW	48	HP6-1000120-2CT	91	K3485	35
HF3B5115CA1L	17	HF5605T	23	HP6-1000120-2CTR	92	KB33	25
HF3B5120CA1L	16	HF5705T	22	HP6-1000120-2T	91	KB46	25
HF3B5120CA1L	17	HF5840TC	80	HP6-1000120-2T	91	KB66	25
HF3B5125CA1L	16	HF5848TC	80	HP6-1000120-2TRP	92	KB79	25
HF3B5125CA1L	17	HF684TC	80	HP6C-12PK	91	KT110	84
HF3B5130CA1L	16	HF685TC	80	HP6H-12PK	91	KT121	84
HF3B5130CA1L	17	HF686TC	80	HP-6-QT	77	KTD110	84
HF3B5140CA1L	16	HLA 12-208160-3.0-24	5	HP8-1440120-2CT	91	KTO110	84
HF3B5140CA1L	17	HLA 12-208160-5.0-24	5	HP8-1440120-2CT	91	KTO121	84
HF3B5150CA1L	16	HLA 12-208160-7.5-24	5	HP8-1440120-2CTR	92	L06Y-01	84



# Product Index Listing

Model	Page	Model	Page	Model	Page	Model	Page
L08Y-01	84	MFHE-0300-6-FAAF2D	92	MS4123	33	P3483A1	35
L8801050	30	MFHE-0300-6-HAA	92	MS4124	33	P3484A1	35
L8802075	30	MFHE-0300-6-HAAF2D	92	MS4125	33	P3485A1	35
L8803100	30	MFHE-0300-6-HAARP	92	MS4126	33	P3G7203	93
L8804125	30	MFHE-0300-8-EAA	92	MS4142	33	P3G7205	93
L8805150	30	MFHE-0300-8-EAAC	92	MS4143	33	P3G7210	93
L8806200	30	MFHE-0300-8-EAACRP	92	MS4144	33	P3G7210-2	93
LVRS	55	MFHE-0300-8-EAARP	92	MS4145	33	P3G7215	93
LVR SB	55	MFHE-0300-8-HAA	92	MS4146	33	P3G7215-2	93
LVR SW	55	MFHE-0300-8-HAARP	92	MSE4140-12	33	P3G7220-2	93
M2903-024CI	54	MM-13A	72	N3472T2i	36	P3G7225-2	93
M2903-24AWi	52	MM-18A	72	N3473T2i	36	P3G7230-2	93
M2905-028CI	54	MM-24A	72	N3474T2i	36	P3G7235-2	93
M2905-28AWi	52	MM-33A	72	N3482T2i	35	P3G7240-2	93
M2906-036CI	54	MM-46A	72	N3483T2i	35	P3G7245-2	93
M2906-36AWi	52	MMWG-13	72	N3484T2i	35	P3G7250-2	93
M2907-040CI	54	MMWG-18	72	OCH-46-120VCE	70	P3G7305	95
M2907-40AWi	52	MMWG-24	72	OCH-46-120VE	70	P3G7310	95
M2910-048CI	54	MMWG-33	72	OCH-46-120V-SSE	70	P3G7310-2	95
M2910-48AWi	52	MMWG-46	72	OCH-46-208VE	70	P3G7312	95
M2912-060CI	54	MR-13	65	OCH-46-208V-SSE	70	P3G7312-2	95
M2912-60AWi	52	MR-1320-3	64	OCH-46-240VE	70	P3G7315	95
M2915-072CI	54	MR-1324-3	64	OCH-46-240V-SSE	70	P3G7315-2	95
M2915-72AWi	52	MR-1327-3	64	OCH-46-277VE	70	P3G7318	95
M2917-084CI	54	MR-1348-3	64	OCH-46-277V-SSE	70	P3G7318-2	95
M2917-84AWi	52	MR-1357-3	64	OCH-57-208VCE	70	P3P2605CA1	21
M2920-096CI	54	MR-2	65	OCH-57-208VE	70	P3P2607CA1	21
M2925-120AWi	52	MR-212-1	64	OCH-57-208V-SSE	70	P3P2610CA1	21
M2925-120CI	54	MR-220-1	64	OCH-57-240VCE	70	P3P2615CA1	21
M3324TD-RPi	40	MR-224-1	64	OCH-57-240VE	70	P3P2620CA1	21
M3325TD-RPi	40	MR-227-1	64	OCH-57-240V-SSE	70	P3P2625CA1	21
M3384D-RPi	34	MR-248-1	64	OCH-57-277VE	70	P3P2630CA1	21
M3385D-RPi	34	MR-257-1	64	OCH-57-277V-SSE	70	P3P2640CA1	21
M3386D-RPi	34	MR-27	65	OCH-57-480VE	70	P3P2650CA1	21
M3472T2i	36	MR-2720-3	64	OCH-57-480V-SSE	70	P3P5103CA1N	16
M3473T2i	36	MR-2724-3	64	OCH-EBK-120	70	P3P5103CA1N	17
M3474T2i	36	MR-2748-3	64	OCH-EBK-208	70	P3P5105CA1N	16
M3482T2i	35	MR-2757-3	64	OCH-EBK-240	70	P3P5105CA1N	17
M3483T2i	35	MR-4	65	OCH-EBK-480	70	P3P5107CA1L	17
M3484T2i	35	MR-420-1	64	OCHWG-46	70	P3P5107CA1N	16
M8801050i	30	MR-424-1	64	OCHWG-57	70	P3P51100CA1	19
M8802075i	30	MR-427-1	64	OFG 51100	18	P3P5110CA1N	16
M8803100i	30	MR-448-1	64	OFG 5175	18	P3P5110CA1N	17
M8804125i	30	MR-457-1	64	OFG5101	15	P3P5115CA1L	17
M8805150i	30	MR-6	65	OFG5102	15	P3P5115CA1N	16
M8806200i	30	MR-620-3	64	OFG5103	15	P3P5120CA1N	16
MCS120-8CT	91	MR-624-3	64	P3472A1	36	P3P5120CA1N	17
MFHE-0300-6-EAA	92	MR-627-3	64	P3473A1	36	P3P5125CA1N	16
MFHE-0300-6-EAAC	92	MR-648-3	64	P3474A1	36	P3P5125CA1N	17
MFHE-0300-6-EAACRP	92	MR-657-3	64	P3475A1	36	P3P5130CA1N	16
MFHE-0300-6-EAARP	92	MS4122	33	P3482A1	35	P3P5130CA1N	17

Model	Page	Model	Page	Model	Page	Model	Page
P3P5140CA1N	16	PD35-1624-3	97	R3H5115CA1	16	RDBT-PDIECR	63
P3P5140CA1N	17	PD40-1624-3	97	R3H5120CA1	16	RDBT-PDOC	63
P3P5150CA1N	16	PD45-1630-3	97	R3H5125CA1	16	RFKit-5	85
P3P5150CA1N	17	PD50-1630-3	97	R3H5130CA1	16	RFKIT-5	92
P3P5160CA1	19	PD5-812-1	97	R3H5140CA1	16	RFR-5	85
P3P5170CA1	19	PD-812-3	97	RCP122	37	RFT-1	85
P3P5180CA1	19	PHLA12-208160-3.0-24-TDP	7	RCP122i	37	RHG-1012A	77
P3P5190CA1	19	PHLA12-208160-5.0-24-TDP	7	RCP123	37	RHG-1012B	77
P3P5503T	11	PHLA12-208160-7.5-24-TDP	7	RCP123i	37	RK120EAA	87
P3P5505T	11	PHLA12-208360-3.0-24-TDP	7	RCP125	37	RK124EAA	87
P3P5507T	11	PHLA12-208360-5.0-24-TDP	7	RCP125i	37	RK130EAA	87
P3P5510T	11	PHLA12-208360-7.5-24-TDP	7	RCP127	37	RK134EAA	87
P3P5515T	11	PHLA12-240160-3.0-24-TDP	7	RCP127i	37	RKWP1AA	87
P3P5520T	11	PHLA12-240160-5.0-24-TDP	7	RCP2202i	37	RMF-222-A	69
P3P5525T	11	PHLA12-240160-7.5-24-TDP	7	RCP2203i	37	RMF-222-SS-A	69
P3P5530T	11	PHLA12-240360-3.0-24-TDP	7	RCP2205i	37	RMF-223	69
P3P5540T	11	PHLA12-240360-5.0-24-TDP	7	RCP2207i	37	RMF-223-SS	69
P3P5548T	11	PHLA12-240360-7.5-24-TDP	7	RCP702	37	RMF-342-A	69
P3P5605T	23	PHLA12-480360-3.0-24-TDP	7	RCP703	37	RMF-342-SS-A	69
P3P5705T	22	PHLA12-480360-5.0-24-TDP	7	RCP705	37	RMF-343	69
P3PUH03CA1	13	PHLA12-480360-7.5-24-TDP	7	RCP707	37	RMF-343-SS	69
P3PUH05CA1	13	PHLA12-600360-3.0-24-TDP	7	RCP802	37	RMF-462-A	69
P3PUH07CA1	13	PHLA12-600360-5.0-24-TDP	7	RCP803	37	RMF-462-SS-A	69
P3PUH10CA1	13	PHLA12-600360-7.5-24-TDP	7	RCP805	37	RMF-463	69
P3PUH12CA1	13	PHLA16-208360-10.0-24-TDP	7	RCP807	37	RMF-463-SS	69
P3PUH15CA1	13	PHLA16-240160-10.0-24-TDP	7	RD5120	15	RPH1-5A	81
P3PUH20CA1	13	PHLA16-240360-10.0-24-TDP	7	RD5120	15	RPH-208-A	72
P3PUH25CA1	13	PHLA16-480360-10.0-24-TDP	7	RD5150	15	RPH22-5Ai	81
P3PUH30CA1	13	PHLA16-600360-10.0-24-TDP	7	RD5150	15	RPH22-5ASi	81
P3PUH40CA1	13	PHLA20-208360-15.0-24-TDP	7	RD5175	15	RPH-240-A	72
P3PUH48CA1	13	PHLA20-240360-15.0-24-TDP	7	RDBT-PD-10	63	RPH2-5A	81
P5520/PMK	10	PHLA20-480360-15.0-24-TDP	7	RDBT-PD-1000BS	63	RPH2-5Ai	81
P5550/PMK	10	PHLA20-480360-20.0-24-TDP	7	RDBT-PD-100BS	63	RPH2-5ASi	81
P8801050	30	PHLA20-480360-25.0-24-TDP	7	RDBT-PD-2	63	RPHWG	72
P8802075	30	PHLA20-600360-15.0-24-TDP	7	RDBT-PD-200BS	63	S2022H10AA	83
P8803100	30	PHLA20-600360-20.0-24-TDP	7	RDBT-PD-3	63	S2022H10AB	83
P8804125	30	PHLA20-600360-25.0-24-TDP	7	RDBT-PD-300BS	63	S2025H10AA	17
P8805150	30	PT3480	35	RDBT-PD-4	63	S2025H10AA	83
P8806200	30	Q3H5103CA1	16	RDBT-PD-400BS	63	SB-6*	92
PCH-48C	77	Q3H5105CA1	16	RDBT-PD-5	63	SB6-120-CT	91
PD10-1018-1	97	Q3H5107CA1	16	RDBT-PD-500BS	63	SB6-120-T	91
PD10-1018-3	97	Q3H5110CA1	16	RDBT-PD-6	63	SB-8*	92
PD15-1218-1	97	Q3H5115CA1	16	RDBT-PD-600BS	63	SB8-120-CT	91
PD15-1218-1-3	97	Q3H5120CA1	16	RDBT-PD-7	63	SB8-120-T	91
PD15-1218-2-3	97	Q3H5125CA1	16	RDBT-PD-700BS	63	SDHW1001	82
PD20-1220-1	97	Q3H5130CA1	16	RDBT-PD-8	63	SF200	37
PD20-1220-3	97	Q3H5140CA1	16	RDBT-PD-800BS	63	SF400	37
PD25-1620-1	97	R3H5103CA1	16	RDBT-PD-9	63	SO 4/4	78
PD25-1620-3	97	R3H5105CA1	16	RDBT-PD-900BS	63	SO 6/4	78
PD30-1624-2-3	97	R3H5107CA1	16	RDBT-PDIC	63	SR120	55
PD30-1624-3-3	97	R3H5110CA1	16	RDBT-PDIECL	63	SR120B	55

# Product Index Listing

Model	Page	Model	Page	Model	Page
SR120W	55	TUH1	13	WWA05	55
SR220	55	TW123	17	WWA06	55
SR220B	55	TW123 / TH5220D	86	WWA07	55
SR220W	55	TW145	84	WWA08	55
T4398A1021	85	TW146	84	WWA09	55
T5100	17	TW1512	17	Y3472A1	36
T5100	17	TW155A	11	Y3473A1	36
T5102	17	TW155A	84	Y3474A1	36
T5122	17	TW255A	11	Y3475A1	36
TAT20-480-3/3BB/1T	89	TW255A	84	Y3482A1	35
TAT24-FAN-120V-1	89	U3H2605CA4	21	Y3483A1	35
TAT-30	89	U3H2607CA4	21	Y3484A1	35
TAT-45	89	U3H2610CA4	21	Y3485A1	35
TAT5-208-1/3BB/1T	89	U3H2615CA4	21	YES-1520-3A	78
TAT5-240-1/3BB/1T	89	U3H2620CA4	21	YES-1524-1A	78
TAT8-208-1/3BB/1T	89	U3U2625CA1	21	YES-1524-3E	78
TAT8-240-1/3BB/1T	89	U3U2630CA1	21	YES-1548-3E	78
TAT-ILC-25	89	U3U2640CA1	21	YES-3048-3A	78
TB3000	34	U3U2650CA1	21		
TB3380	34	U8801050	30		
TBD	55	U8802075	30		
TBD-TP	55	U8803100	30		
TBS	55	U8804125	30		
TBS-TP	55	U8805150	30		
TC1602	17	U8806200	30		
TC1602	22	UHB-1	13		
TC5102	17	UHB-3	13		
TC5103	17	UHB-4	13		
TF-33	25	UT1001	87		
TF-46	25	UT3001	87		
TF-66	25	UT5001	87		
TF-79	25	UT6001	87		
TFS5101	17	UT8001	87		
TFS5102	17	UT9001	87		
TG1	87	V5105	15		
TG1B	87	V51100	18		
TG2	87	V5120	15		
TG2B	87	V5150	15		
TG3	87	VHC-15	70		
TG3B	87	VHC-15	74		
TG4	87	VHC-32	70		
TG5	87	VHC-32	74		
TG6	87	VMB-41-SS	69		
TH115-A-024T	86	VMB-41-SS	70		
TH148LE-P	86	W5520/WMK	10		
TL8230A1003	85	W5550/WMK	10		
TO-SK-1	76	WWA00	55		
TSH1TX	81	WWA01	55		
TSH20J	81	WWA02	55		
TSH20JW	81	WWA03	55		
TSH2TX	81	WWA04	55		