

**RIGID PVC CONDUIT FITTINGS**

**ISSUE DATE:**  
**DATE D'EMISSION:** 2014 07 23

**TYPE "LR" ACCESS FITTINGS**

**SUPERCEDES:**  
**REPLACE:** 2002 12 05

3

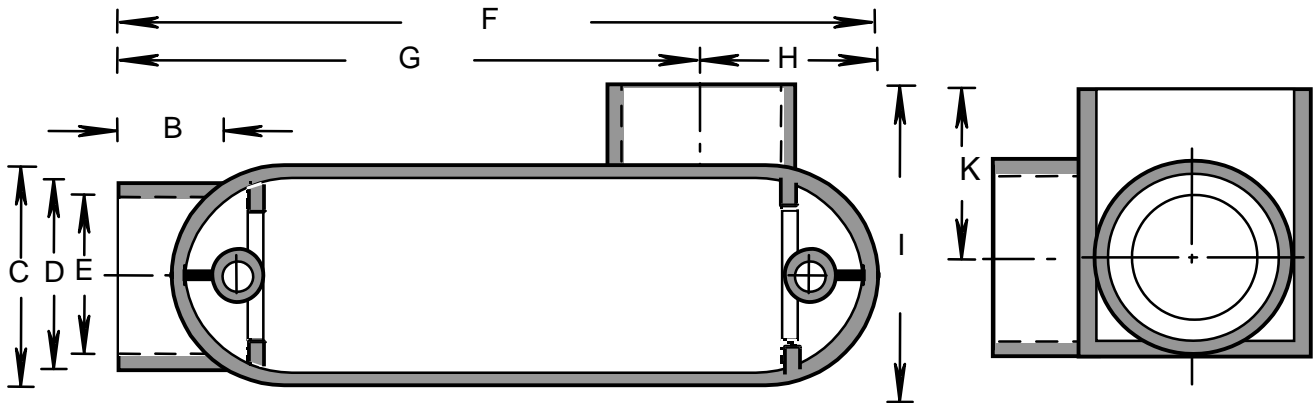

PRODUCT CODE	PART NUMBER	NOMINAL SIZE		B		C		D	
		(in)	(mm)	(in)	(mm)	(in)	(mm)	(in)	(mm)
077480	SLR10S	1/2	16	0.639	16.2	1.270	32.3	1.100	27.9
077481	SLR20S	3/4	21	0.810	20.6	1.540	39.1	1.325	33.7
077482	SLR30S	1	27	0.910	23.1	1.700	43.2	1.600	40.6
077483	SLR40S	1 1/4	35	1.050	26.7	2.300	58.4	2.250	57.2
077484	SLR50S	1 1/2	41	1.125	28.6	2.675	67.9	2.250	57.2
077485	SLR60S	2	53	1.160	29.5	3.190	81.0	2.820	71.6
077486	SLR70S	2 1/2	63	1.750	44.5	4.500	114.3	3.950	100.3
077487	SLR80S	3	78	1.900	48.3	4.500	114.3	3.950	100.3
077488	SLR90S	3 1/2	91	2.125	54.0	5.540	140.7	5.000	127.0
077489	SLR100S	4	103	2.125	54.0	5.540	140.7	5.000	127.0

PRODUCT CODE	PART NUMBER	NOMINAL SIZE		E		F		G		H	
		(in)	(mm)	(in)	(mm)	(in)	(mm)	(in)	(mm)	(in)	(mm)
077480	SLR10S	1/2	16	0.840	21.3	4.340	110.2	4.095	104.0	1.297	32.9
077481	SLR20S	3/4	21	1.050	26.7	5.395	137.0	4.095	104.0	1.297	32.9
077482	SLR30S	1	27	1.335	33.9	6.250	158.8	4.750	120.7	1.500	38.1
077483	SLR40S	1 1/4	35	1.660	42.2	7.625	193.7	5.750	146.1	1.750	44.5
077484	SLR50S	1 1/2	41	1.900	48.3	8.250	209.6	6.500	165.1	1.750	44.5
077485	SLR60S	2	53	2.375	60.3	10.530	267.5	8.160	207.3	2.350	59.7
077486	SLR70S	2 1/2	63	2.870	72.9	13.630	346.2	9.825	249.6	3.805	96.6
077487	SLR80S	3	78	3.510	89.2	13.630	346.2	10.900	276.9	2.735	69.5
077488	SLR90S	3 1/2	91	4.000	101.6	16.000	406.4	11.465	291.2	4.535	115.2
077489	SLR100S	4	103	4.530	115.1	16.000	406.4	11.465	291.2	4.535	115.2

**RIGID PVC CONDUIT FITTINGS**

**ISSUE DATE:**  
**DATE D'EMISSION:** 2014 07 23

**TYPE "LR" ACCESS FITTINGS**

**SUPERCEDES:**  
**REPLACE:** 2002 12 05

3

PRODUCT CODE	PART NUMBER	NOMINAL SIZE		I		K		WALL THICK.*	
		(in)	(mm)	(in)	(mm)	(in)	(mm)	(in)	(mm)
077480	SLR10S	1/2	16	2.490	63.2	1.005	25.5	0.125	3.2
077481	SLR20S	3/4	21	2.490	63.2	1.005	25.5	0.125	3.2
077482	SLR30S	1	27	2.075	52.7	1.125	28.6	0.125	3.2
077483	SLR40S	1 1/4	35	3.575	90.8	1.560	39.6	0.156	4.0
077484	SLR50S	1 1/2	41	3.940	100.1	1.660	42.2	0.156	4.0
077485	SLR60S	2	53	4.535	115.2	1.970	50.0	0.203	5.2
077486	SLR70S	2 1/2	63	6.240	158.5	2.610	66.3	0.235	6.0
077487	SLR80S	3	78	6.240	158.5	2.610	66.3	0.235	6.0
077488	SLR90S	3 1/2	91	7.500	190.5	2.975	75.6	0.240	6.1
077489	SLR100S	4	103	7.500	190.5	2.975	75.6	0.240	6.1

\* WALL THICKNESS MEASURED AT 1/4" FROM TOP OF CONDUIT BODY

PRODUCT CODE	PART NUMBER	NOMINAL SIZE		FILL VOLUME		INSERT CODE	SCREW CODE	REDUCER CODE	COVER CODE	GASKET CODE
		(in)	(mm)	(cu.in)	(cu.cm)					
077480	SLR10S	1/2	16	4.2	68.9	072537	072521			097950
077481	SLR20S	3/4	21	7.6	124.6	072538	072522			097951
077482	SLR30S	1	27	13.1	214.8	072538	072522			097952
077483	SLR40S	1 1/4	35	26.6	436.2	072538	072522			097953
077484	SLR50S	1 1/2	41	39.0	639.6	072538	072522		097965	097954
077485	SLR60S	2	53	70.9	1162.8	072538	072522		097966	097955
077486	SLR70S	2 1/2	63	178.5	2927.4	072549	072516	097558	097957	097961
077487	SLR80S	3	78	178.2	2922.5	072549	072516		097957	097961
077488	SLR90S	3 1/2	91	338.6	5553.0	072549	072516	097991	097959	097963
077489	SLR100S	4	103	338.6	5553.0	072549	072516		097959	097963

**MAXIMUM WIRE FILL**

		1 1/4"	1 1/2"	2"	2 1/2"	3"	3 1/2"	4"
		(35)	(41)	(53)	(63)	(78)	(91)	(103)
1/2" + 3/4" + 1" (12 + 21 + 27)								
MAX. WIRE FILL #6 AWG CONDUCTORS OR SMALLER	U	2.720" (69.1)	4.480" (113.8)	5.750" (146.1)	7.420" (188.5)	7.420" (188.5)	8.940" (227.1)	7.940" (201.7)
	M	#2	#1 /0	#4 /0	#300	#300	#350	#350
	D	4.750" (120.7)	5.500" (139.7)	6.875" (174.6)	7.750" (196.9)	7.750" (196.9)	9.500" (241.3)	9.500" (241.3)

U UL514 INVESTIGATION OF CONDUIT BODIES FOR THREE CONDUCTOR INSTALLATION WITH NO INVESTIGATION  
M MAXIMUM WIRE FILL MARKED ON CONDUIT BODY  
D DISTANCE BETWEEN HUBS ON CONDUIT BODY

