

ND4R/ ND4S

LED EMERGENCY BATTERY BACK UP INSTALLATION INSTRUCTIONS

RAB
LIGHTING

Thank you for buying RAB lighting fixtures. Our goal is to design the best quality products to get the job done right. We'd like to hear your comments. Call the Marketing Department at 888-RAB-1000 or email: marketing@rabweb.com

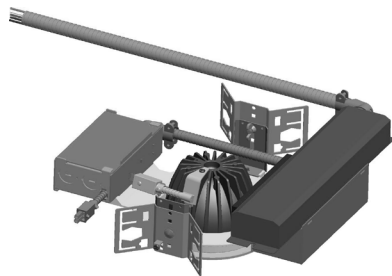

ND4R
Cut-Out Diameter: 5"

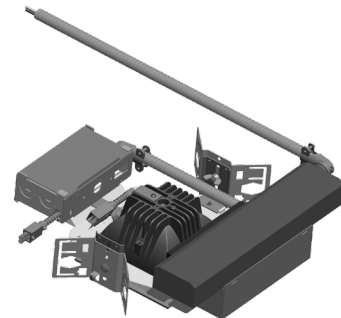

ND4S
Cut-Out: 5"x5"

IMPORTANT

READ CAREFULLY BEFORE INSTALLING FIXTURE. RETAIN THESE INSTRUCTIONS FOR FUTURE REFERENCE.

Fixtures must be wired in accordance with the National Electrical Code and all applicable local codes. Proper grounding is required for safety. THIS PRODUCT MUST BE INSTALLED IN ACCORDANCE WITH THE APPLICABLE INSTALLATION CODE BY A PERSON FAMILIAR WITH THE CONSTRUCTION AND OPERATION OF THE PRODUCT AND THE HAZARDS INVOLVED.

WARNING: Make certain power is OFF before installing or maintaining fixture. No user serviceable parts inside.

THIS IS AN EMERGENCY BATTERY BACKUP FIXTURE THAT CONTAINS A RECHARGEABLE NICKEL-CADMIUM BATTERY. THE BATTERY MUST BE RECYCLED OR DISPOSED OFF PROPERLY.

SAFETY INSTRUCTIONS

WARNING: Risk of fire or electric shock. Suitable for Damp locations where the ambient temperature is 0°C minimum, +50°C maximum. Not suitable for heated air outlets and wet or hazardous locations. Do not install near gas or electric heaters.

WARNING: Suitable for 9/16" or 15/16" Flat Tee Grid in both Insulated Ceilings and Non-Insulated Ceilings. Access above ceiling required.

WARNING: Do not handle energized fixture when hands are wet, when standing on wet or damp surfaces, or in water.

WARNING: Vapor barrier must be suitable for 90°C.

WARNING: Fixture to be independently supported to building structure.

MOUNTING BARS

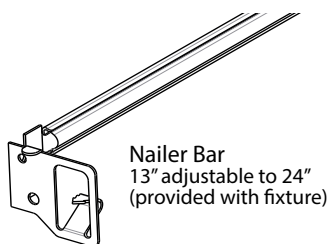

Nailer Bar
13" adjustable to 24"
(provided with fixture)

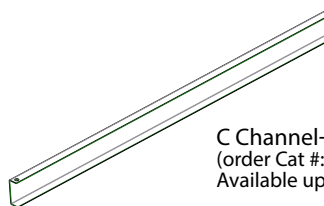

C Channel-27"
(order Cat #: C-Chan 27)
Available upon request

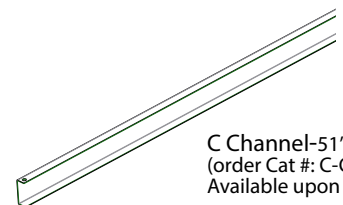

C Channel-51"
(order Cat #: C-Chan 51)
Available upon request

OPERATION

1. When AC power is applied, the charging indicator light is illuminated, indicating that the battery is being charged.
2. When power fails, the emergency ballast automatically switches to emergency power (internal battery), operating at reduced illumination. The emergency ballast supplies 7W of power (measured at nominal battery voltage) at a maximum rated current of 270mA with a maximum voltage of 50VDC in emergency mode for a minimum of 90 minutes.
3. When AC power is restored, the emergency ballast automatically returns to charging mode.

ND4R/ ND4S

LED EMERGENCY BATTERY BACK UP INSTALLATION INSTRUCTIONS

RAB
LIGHTING

Thank you for buying RAB lighting fixtures. Our goal is to design the best quality products to get the job done right. We'd like to hear your comments. Call the Marketing Department at 888-RAB-1000 or email: marketing@rabweb.com

ROUGH-IN MOUNTING

The fixture is suitable only for INDOOR RECESSED CEILING application. Charging indicator test switch should be visible and accessible and be located nominal 2 feet from the fixture. Access above the ceiling is necessary.

1. Nailer bars are provided for use with wood joist installations. Insert through **Nailer Bar Slots** in **Butterfly Brackets** and secure accordingly. C-Channels are optionally available, consult factory. Consult local building codes for final support of fixture.
2. Remove appropriate **Knock out** on Junction box. Press **Clip** to open the **Junction Box**.
3. Feed the supply wires through **Knock out** hole and connect to the driver. See wiring section for details. Connect Inverter Plug only after supply wiring is complete. (see wiring instructions).
4. The fixture can be adjusted to different heights above the ceiling surface. For height adjustment, loosen the **Wing Nut** and slide the **Butterfly Bracket**. If necessary remove the **Wing Nut** and insert in screw in different hole provided on the **Butterfly Bracket**. (Fig: 2)
5. Adjust both the **Butterfly Brackets** such that the frame of **Rough-In Section** is flush with the finished ceiling surface. Tighten the **Wing nuts**.
6. Install the **Switch Plate** (along with the charging indicator) in a suitable **Junction Box (by others)** in an adjacent ceiling tile. It should be located nominal 2 feet from the fixture.

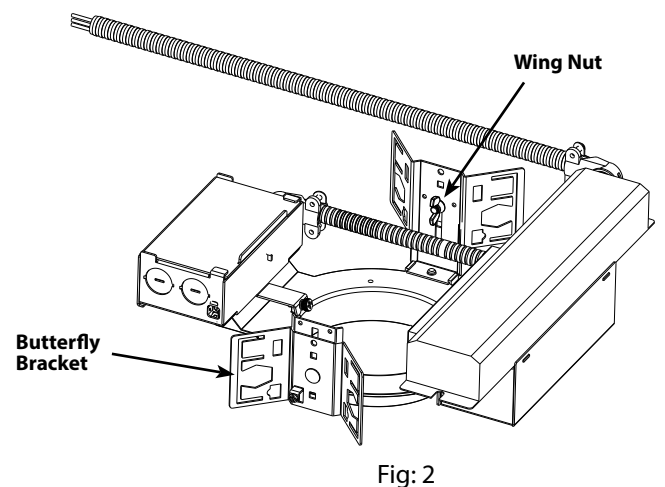
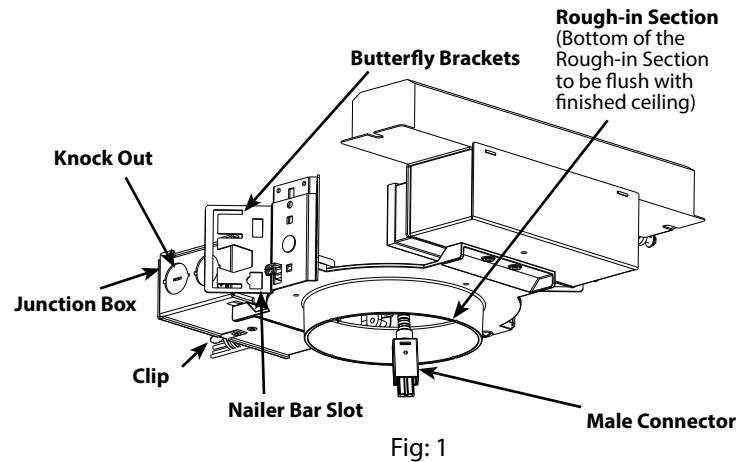

TRIM MODULE MOUNTING

1. Pull **Female Connector** conduit through frame opening. Raise **Trim Module** towards opening and connect to **Male Connector** conduit.
2. Press **Torsion Springs** inward and slide **Trim Module** into frame opening. Release both springs into opening together. **Trim Ring** should be flush to ceiling.
3. For the Wallwash Model, orient the fixture such that the reflector is in correct orientation. Look for 'Towards the Wall' label on the fixture.

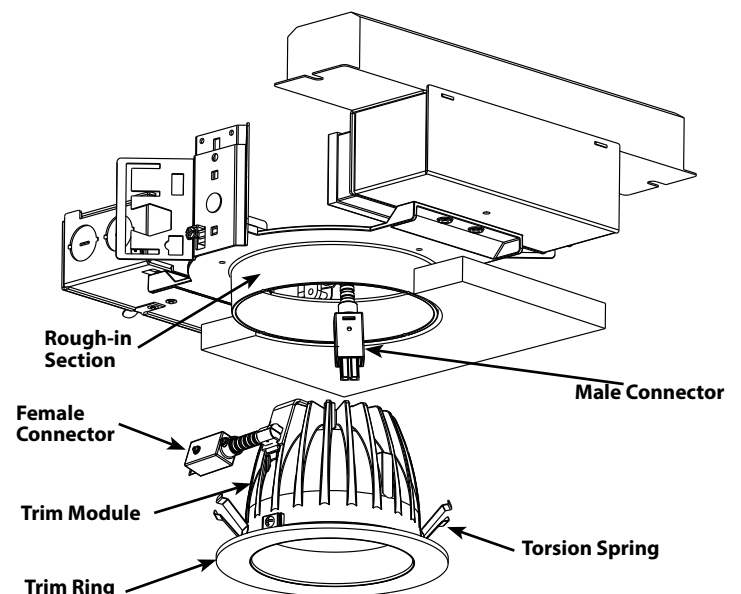

ND4R/ ND4S

LED EMERGENCY BATTERY BACK UP INSTALLATION INSTRUCTIONS



Thank you for buying RAB lighting fixtures. Our goal is to design the best quality products to get the job done right. We'd like to hear your comments. Call the Marketing Department at 888-RAB-1000 or email: marketing@rabweb.com

WIRING

CAUTION: THIS IS AN EMERGENCY BATTERY BACKUP FIXTURE. Voltage could be present in Battery. To prevent high voltage from being present on output leads, inverter connector must be open. Do not join inverter connector until installation is complete and AC power is supplied to the emergency ballast.

NOTE: Make sure that the necessary branch circuit wiring is available. An unswitched AC source of power is required. The emergency ballast must be fed from the same branch circuit as the AC ballast.

Do not use any supply voltage other than those specified below.

ND4R/E2 or ND4S/E2	120V-277V, 50/60Hz
ND4R/E1 or ND4S/E1	120V, 50/60Hz

1. Connect the UNSWITCHED black fixture lead to the HOT supply lead.
2. Connect red and black lead together, if not using a switching method.
3. If switching, connect SWITCHED red lead to a switch.
4. Connect the COMMON fixture lead to the COMMON supply lead.
5. For Lutron system, follow manufacturer's instructions.
5. Connect the GROUND wire from fixture to supply ground. Do NOT connect the GROUND of the dimming fixture to the output.
6. All unused leads must be capped and insulated.
7. After installation is complete, supply AC power to the emergency ballast and join the inverter connector.
9. At this point, power should be connected to both the AC ballast and the emergency ballast, and the Charging Indicator Light should illuminate indicating the battery is charging.
10. A short-term discharge test may be conducted after the emergency ballast has been charging for one hour. Charge for 24 hours before conducting a long-term discharge test. Refer to OPERATION.

To reduce the risk of electric shock, disconnect both normal and emergency power supplies and converter connector of the emergency ballast before servicing. Do not attempt to service the emergency ballast. The use of accessory equipment may cause an unsafe condition. Do not use this product for other than intended use. Refer any servicing indicated by these checks to a Qualified Service Personnel.

TROUBLESHOOTING

1. Check that the line voltage at the fixture is correct. Refer to wiring directions.
2. Is the fixture grounded properly?
3. For questions on compatibility of dimmers purchased separately refer to www.rabweb.com
4. If the LED is blinking the fixture may be overheating. Remove the Trim assembly and if the fixture is labeled 'BLINKING LIGHT OF THIS THERMALLY PROTECTED LUMINAIRE MAY INDICATE OVERHEATING' allow the fixture to cool down. Determine cause of overheating and remove. Fixtures with this label have a thermal protector that turns fixture off above a certain temperature. It will automatically restart when cool.

CLEANING

CAUTION: Be sure fixture temperature is cool enough to touch. Do not clean or maintain while fixture is energized.

1. Do not open fixture to clean the LEDs. Do not touch the LEDs.
2. Do not touch reflector, lens, or trim cone.
3. Do not clean any fixture surface with wood base cleaning material such as paper towels or tissues. Only use micro fiber cleaning cloth.

MAINTENANCE

Although no routine maintenance is required to keep the emergency ballast functional, it should be checked periodically to ensure that it is working. The following schedule is recommended:

1. Visually inspect the charging indicator light monthly. It should be illuminated.
2. Test the emergency operation of the fixture at 30-day intervals for a minimum of 30 seconds.
3. Conduct a 90-minute discharge test once a year. Fixture would operate at reduced illumination for a minimum of 90 minutes.

Note: These instructions do not cover all details or variations in equipment nor do they provide for every possible situation during installation, operation or maintenance.

ND4R/ ND4S

LED EMERGENCY BATTERY BACK UP INSTALLATION INSTRUCTIONS



Thank you for buying RAB lighting fixtures. Our goal is to design the best quality products to get the job done right. We'd like to hear your comments. Call the Marketing Department at 888-RAB-1000 or email: marketing@rabweb.com

DIMENSIONAL DRAWING

ND4R

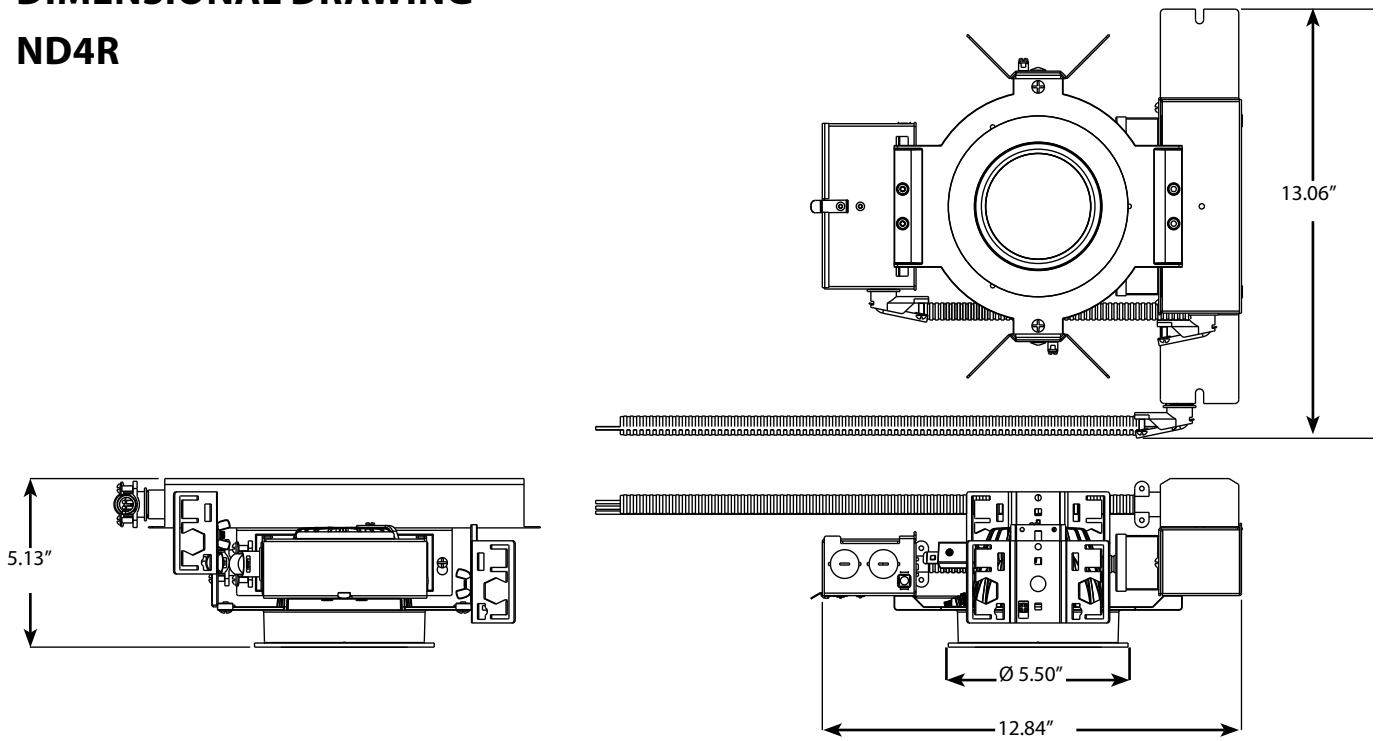

ND4S

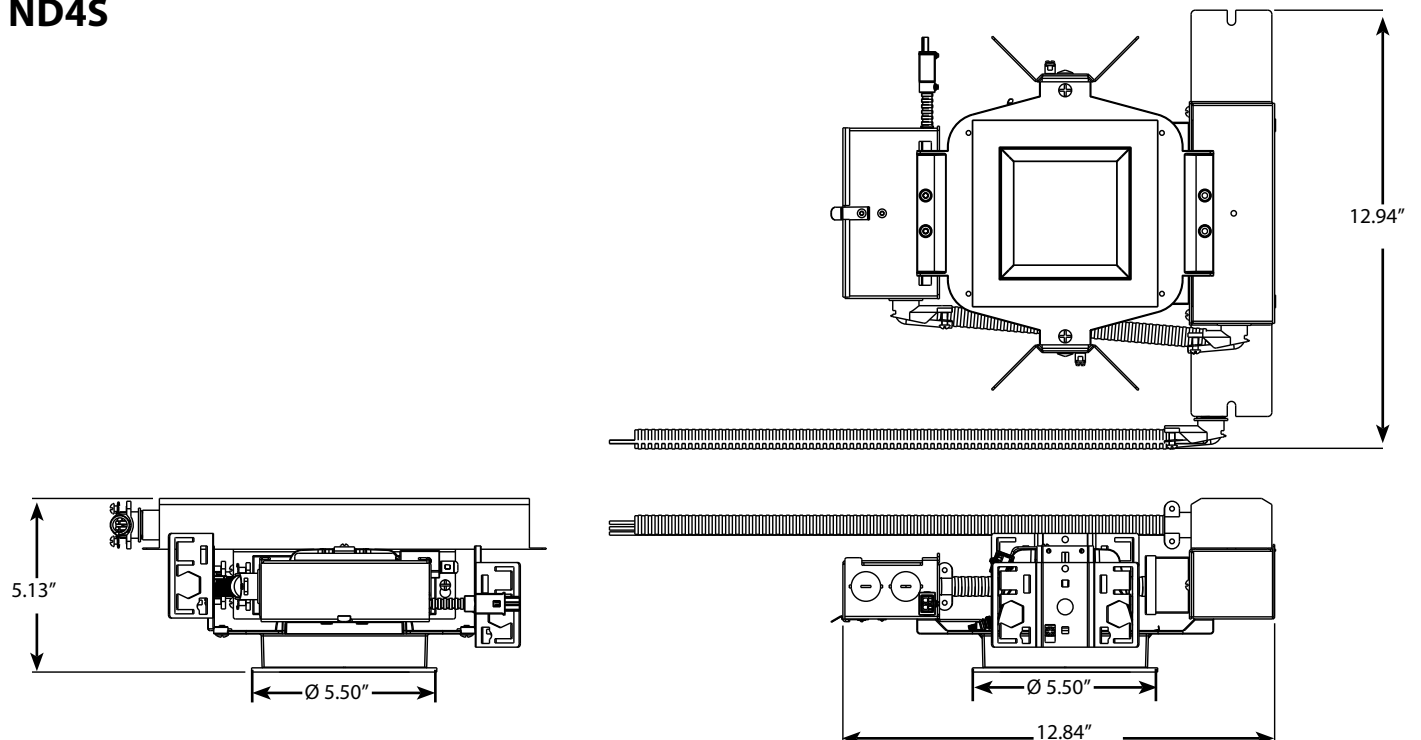

WIRING DIAGRAM for EMERGENCY OPERATION at 120V - 277V

Emergency Ballast and AC Ballast must be fed from the same circuit

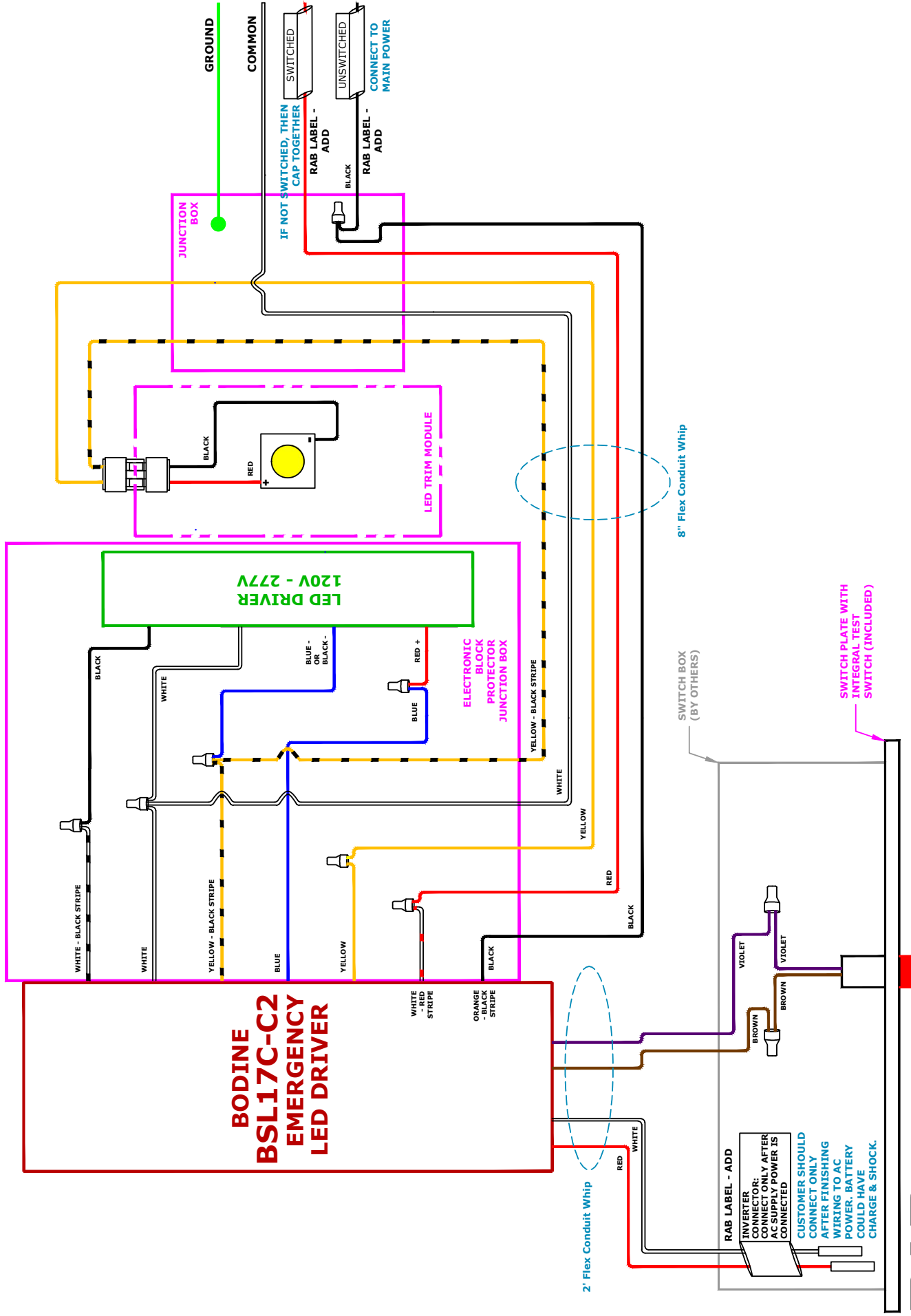

WIRING DIAGRAM for EMERGENCY OPERATION at 120V - 277V with Thermal Protector

Emergency Ballast and AC Ballast must be fed from the same circuit

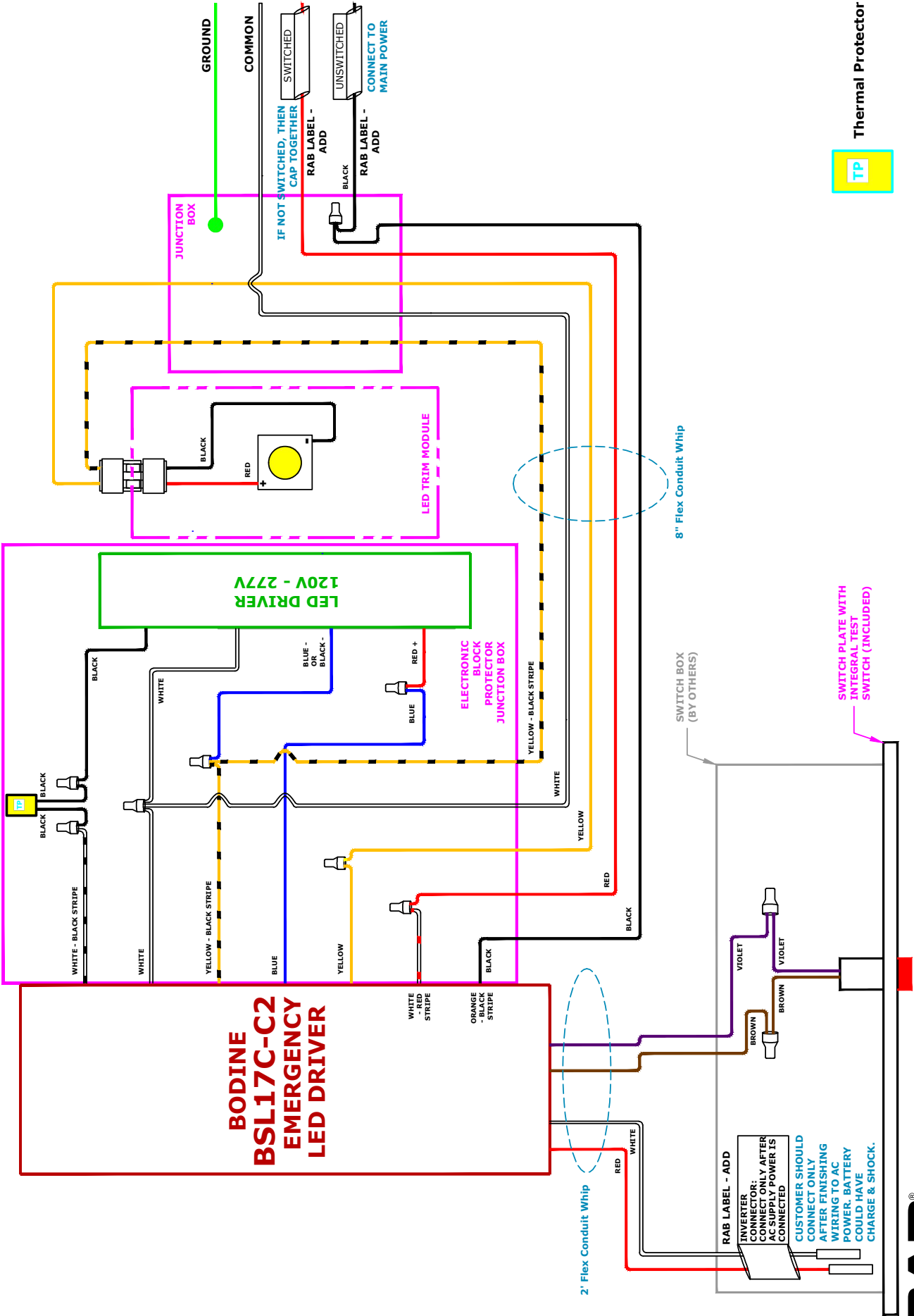

ND6R/ ND6S

LED EMERGENCY BATTERY BACK UP INSTALLATION INSTRUCTIONS

RAB
LIGHTING

Thank you for buying RAB lighting fixtures. Our goal is to design the best quality products to get the job done right. We'd like to hear your comments. Call the Marketing Department at 888-RAB-1000 or email: marketing@rabweb.com

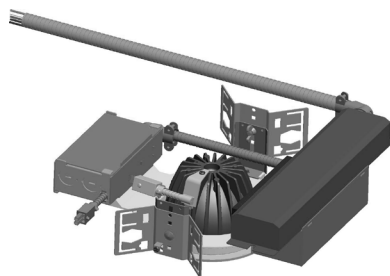

ND6R
Cut-Out Diameter: 7"

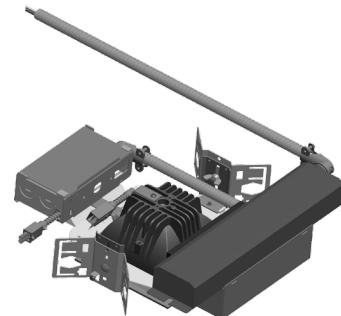

ND6S
Cut-Out: 7"x7"

IMPORTANT

READ CAREFULLY BEFORE INSTALLING FIXTURE. RETAIN THESE INSTRUCTIONS FOR FUTURE REFERENCE.

Fixtures must be wired in accordance with the National Electrical Code and all applicable local codes. Proper grounding is required for safety. THIS PRODUCT MUST BE INSTALLED IN ACCORDANCE WITH THE APPLICABLE INSTALLATION CODE BY A PERSON FAMILIAR WITH THE CONSTRUCTION AND OPERATION OF THE PRODUCT AND THE HAZARDS INVOLVED.

WARNING: Make certain power is OFF before installing or maintaining fixture. No user serviceable parts inside.

THIS IS AN EMERGENCY BATTERY BACKUP FIXTURE THAT CONTAINS A RECHARGEABLE NICKEL-CADMIUM BATTERY. THE BATTERY MUST BE RECYCLED OR DISPOSED OFF PROPERLY.

SAFETY INSTRUCTIONS

WARNING: Risk of fire or electric shock. Suitable for Damp locations where the ambient temperature is 0°C minimum, +50°C maximum. Not suitable for heated air outlets and wet or hazardous locations. Do not install near gas or electric heaters.

WARNING: Suitable for 9/16" or 15/16" Flat Tee Grid in both Insulated Ceilings and Non-Insulated Ceilings. Access above ceiling required.

WARNING: Do not handle energized fixture when hands are wet, when standing on wet or damp surfaces, or in water.

WARNING: Vapor barrier must be suitable for 90°C.

WARNING: Fixture to be independently supported to building structure.

MOUNTING BARS

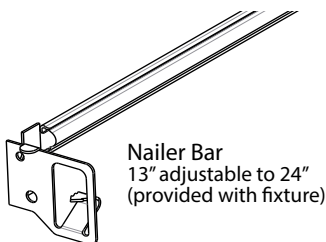

Nailer Bar
13" adjustable to 24"
(provided with fixture)

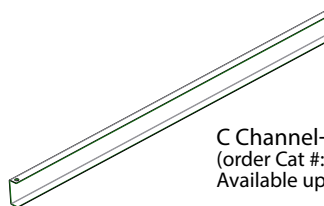

C Channel-27"
(order Cat #: C-Chan 27)
Available upon request

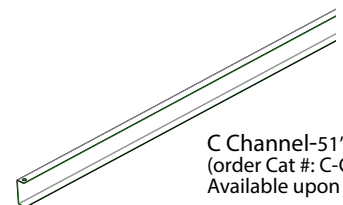

C Channel-51"
(order Cat #: C-Chan 51)
Available upon request

OPERATION

1. When AC power is applied, the charging indicator light is illuminated, indicating that the battery is being charged.
2. When power fails, the emergency ballast automatically switches to emergency power (internal battery), operating at reduced illumination. The emergency ballast supplies 7W of power (measured at nominal battery voltage) at a maximum rated current of 270mA with a maximum voltage of 50VDC in emergency mode for a minimum of 90 minutes.
3. When AC power is restored, the emergency ballast automatically returns to charging mode.

ND6R/ ND6S

LED EMERGENCY BATTERY BACK UP INSTALLATION INSTRUCTIONS

RAB
LIGHTING

Thank you for buying RAB lighting fixtures. Our goal is to design the best quality products to get the job done right. We'd like to hear your comments. Call the Marketing Department at 888-RAB-1000 or email: marketing@rabweb.com

ROUGH-IN MOUNTING

The fixture is suitable only for INDOOR RECESSED CEILING application. Charging indicator test switch should be visible and accessible and be located nominal 2 feet from the fixture. Access above the ceiling is necessary.

1. Nailer bars are provided for use with wood joist installations. Insert through **Nailer Bar Slots** in **Butterfly Brackets** and secure accordingly. C-Channels are optionally available, consult factory. Consult local building codes for final support of fixture.
2. Remove appropriate **Knock out** on Junction box. Press **Clip** to open the **Junction Box**.
3. Feed the supply wires through **Knock out** hole and connect to the driver. See wiring section for details. Connect Inverter Plug only after supply wiring is complete. (see wiring instructions).
4. The fixture can be adjusted to different heights above the ceiling surface. For height adjustment, loosen the **Wing Nut** and slide the **Butterfly Bracket**. If necessary remove the **Wing Nut** and insert in screw in different hole provided on the **Butterfly Bracket**. (Fig: 2)
5. Adjust both the **Butterfly Brackets** such that the frame of **Rough-In Section** is flush with the finished ceiling surface. Tighten the **Wing nuts**.
6. Install the **Switch Plate** (along with the charging indicator) in a suitable **Junction Box (by others)** in an adjacent ceiling tile. It should be located nominal 2 feet from the fixture.

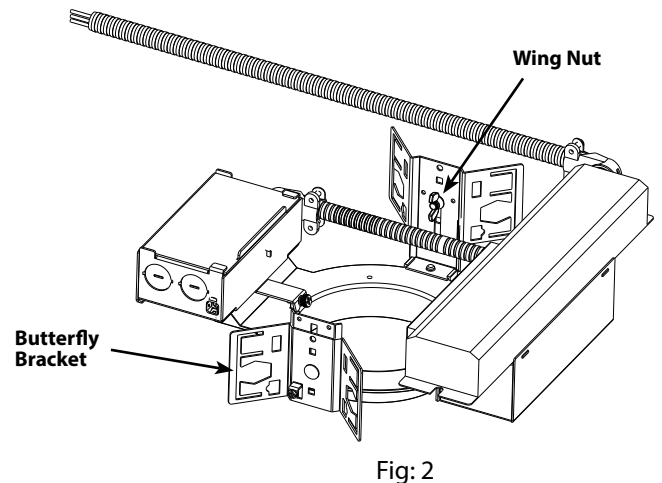
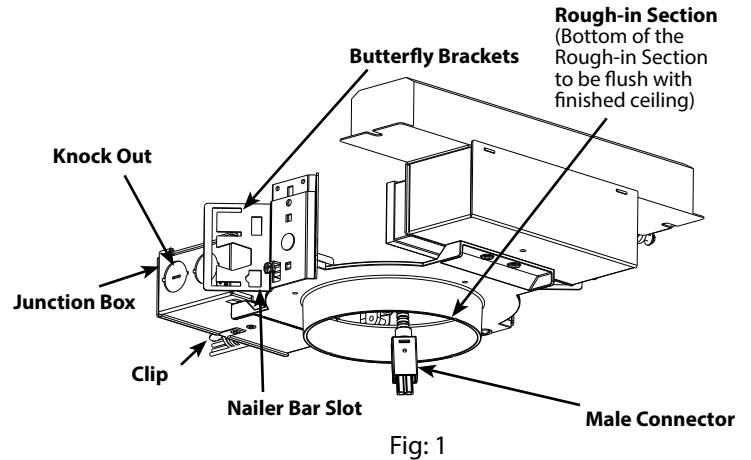

TRIM MODULE MOUNTING

1. Pull **Female Connector** conduit through frame opening. Raise **Trim Module** towards opening and connect to **Male Connector** conduit.
2. Press **Torsion Springs** inward and slide **Trim Module** into frame opening. Release both springs into opening together. **Trim Ring** should be flush to ceiling.
3. For the Wallwash Model, orient the fixture such that the reflector is in correct orientation. Look for 'Towards the Wall' label on the fixture.

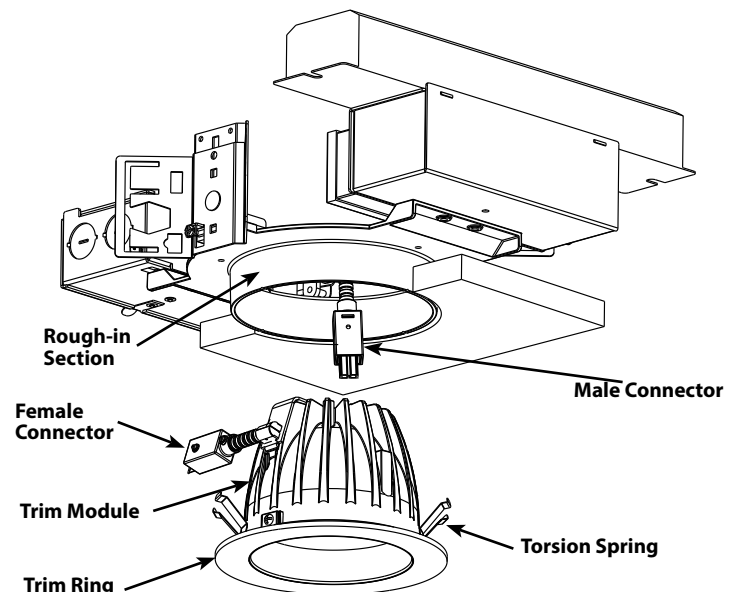

ND6R/ ND6S

LED EMERGENCY BATTERY BACK UP INSTALLATION INSTRUCTIONS



Thank you for buying RAB lighting fixtures. Our goal is to design the best quality products to get the job done right. We'd like to hear your comments. Call the Marketing Department at 888-RAB-1000 or email: marketing@rabweb.com

WIRING

CAUTION: THIS IS AN EMERGENCY BATTERY BACKUP FIXTURE. Voltage could be present in Battery. To prevent high voltage from being present on output leads, inverter connector must be open. Do not join inverter connector until installation is complete and AC power is supplied to the emergency ballast.

NOTE: Make sure that the necessary branch circuit wiring is available. An unswitched AC source of power is required. The emergency ballast must be fed from the same branch circuit as the AC ballast.

Do not use any supply voltage other than those specified below.

ND6R/E2 or ND6S/E2	120V-277V, 50/60Hz
ND6R/E1 or ND6S/E1	120V, 50/60Hz

1. Connect the UNSWITCHED black fixture lead to the HOT supply lead.
2. Connect red and black lead together, if not using a switching method.
3. If switching, connect SWITCHED red lead to a switch.
4. Connect the COMMON fixture lead to the COMMON supply lead.
5. For Lutron system, follow manufacturer's instructions.
5. Connect the GROUND wire from fixture to supply ground. Do NOT connect the GROUND of the dimming fixture to the output.
6. All unused leads must be capped and insulated.
7. After installation is complete, supply AC power to the emergency ballast and join the inverter connector.
9. At this point, power should be connected to both the AC ballast and the emergency ballast, and the Charging Indicator Light should illuminate indicating the battery is charging.
10. A short-term discharge test may be conducted after the emergency ballast has been charging for one hour. Charge for 24 hours before conducting a long-term discharge test. Refer to OPERATION.

To reduce the risk of electric shock, disconnect both normal and emergency power supplies and converter connector of the emergency ballast before servicing. Do not attempt to service the emergency ballast. The use of accessory equipment may cause an unsafe condition. Do not use this product for other than intended use. Refer any servicing indicated by these checks to a Qualified Service Personnel.

TROUBLESHOOTING

1. Check that the line voltage at the fixture is correct. Refer to wiring directions.
2. Is the fixture grounded properly?
3. For questions on compatibility of dimmers purchased separately refer to www.rabweb.com
4. If the LED is blinking the fixture may be overheating. Remove the Trim assembly and if the fixture is labeled 'BLINKING LIGHT OF THIS THERMALLY PROTECTED LUMINAIRE MAY INDICATE OVERHEATING' allow the fixture to cool down. Determine cause of overheating and remove. Fixtures with this label have a thermal protector that turns fixture off above a certain temperature. It will automatically restart when cool.

CLEANING

CAUTION: Be sure fixture temperature is cool enough to touch. Do not clean or maintain while fixture is energized.

1. Do not open fixture to clean the LEDs. Do not touch the LEDs.
2. Do not touch reflector, lens, or trim cone.
3. Do not clean any fixture surface with wood base cleaning material such as paper towels or tissues. Only use micro fiber cleaning cloth.

MAINTENANCE

Although no routine maintenance is required to keep the emergency ballast functional, it should be checked periodically to ensure that it is working. The following schedule is recommended:

1. Visually inspect the charging indicator light monthly. It should be illuminated.
2. Test the emergency operation of the fixture at 30-day intervals for a minimum of 30 seconds.
3. Conduct a 90-minute discharge test once a year. Fixture would operate at reduced illumination for a minimum of 90 minutes.

Note: These instructions do not cover all details or variations in equipment nor do they provide for every possible situation during installation, operation or maintenance.



Easy Installation & Product Help

Tech Help Line
Call our experts 888 RAB-1000

rabweb.com
Visit our website for product info

email
Answered promptly sales@rabweb.com

ND6R/ ND6S

LED EMERGENCY BATTERY BACK UP INSTALLATION INSTRUCTIONS



Thank you for buying RAB lighting fixtures. Our goal is to design the best quality products to get the job done right. We'd like to hear your comments. Call the Marketing Department at 888-RAB-1000 or email: marketing@rabweb.com

DIMENSIONAL DRAWING

ND6R

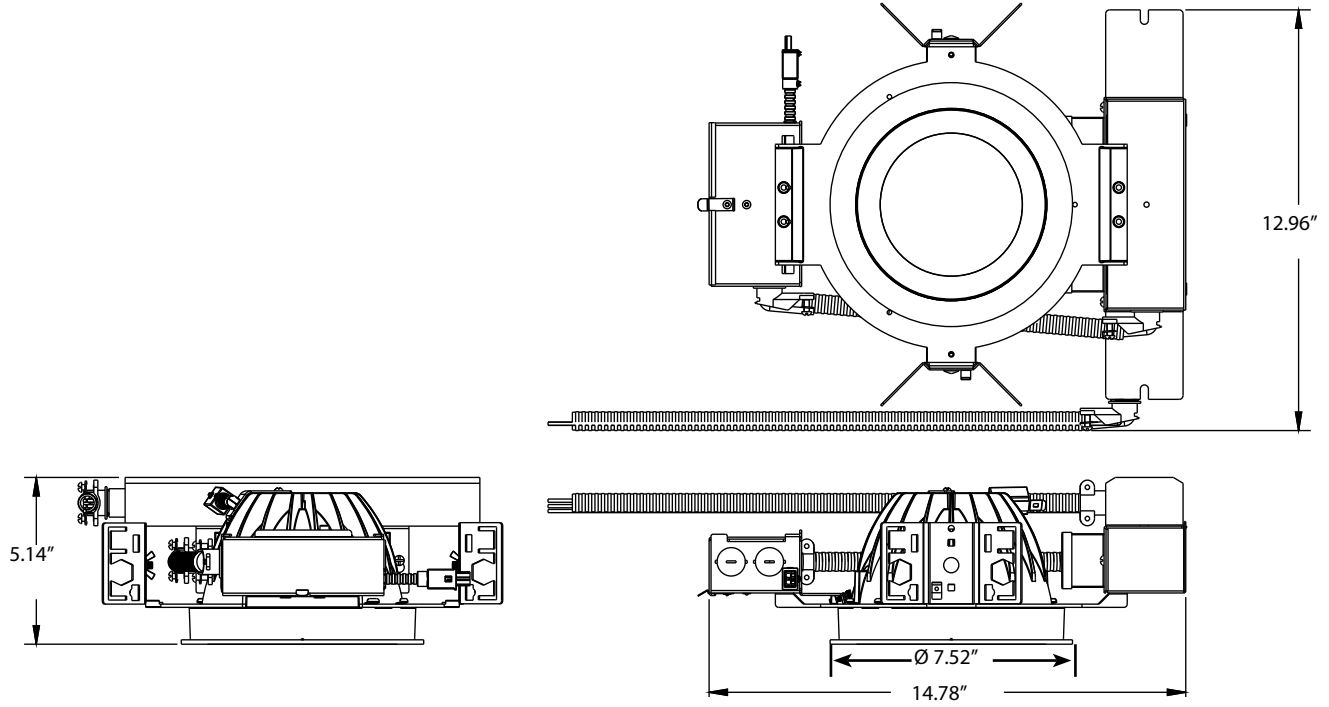

ND6S

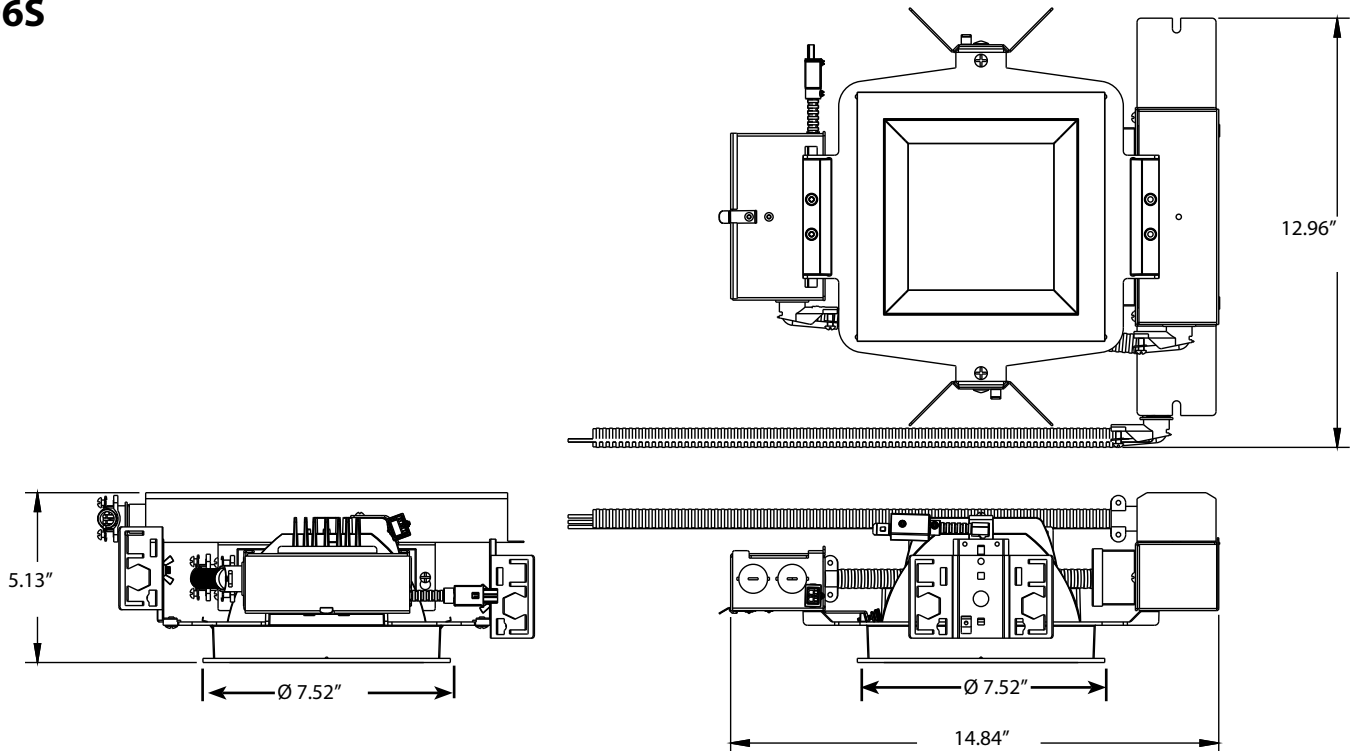

WIRING DIAGRAM for EMERGENCY OPERATION at 120V - 277V

Emergency Ballast and AC Ballast must be fed from the same circuit

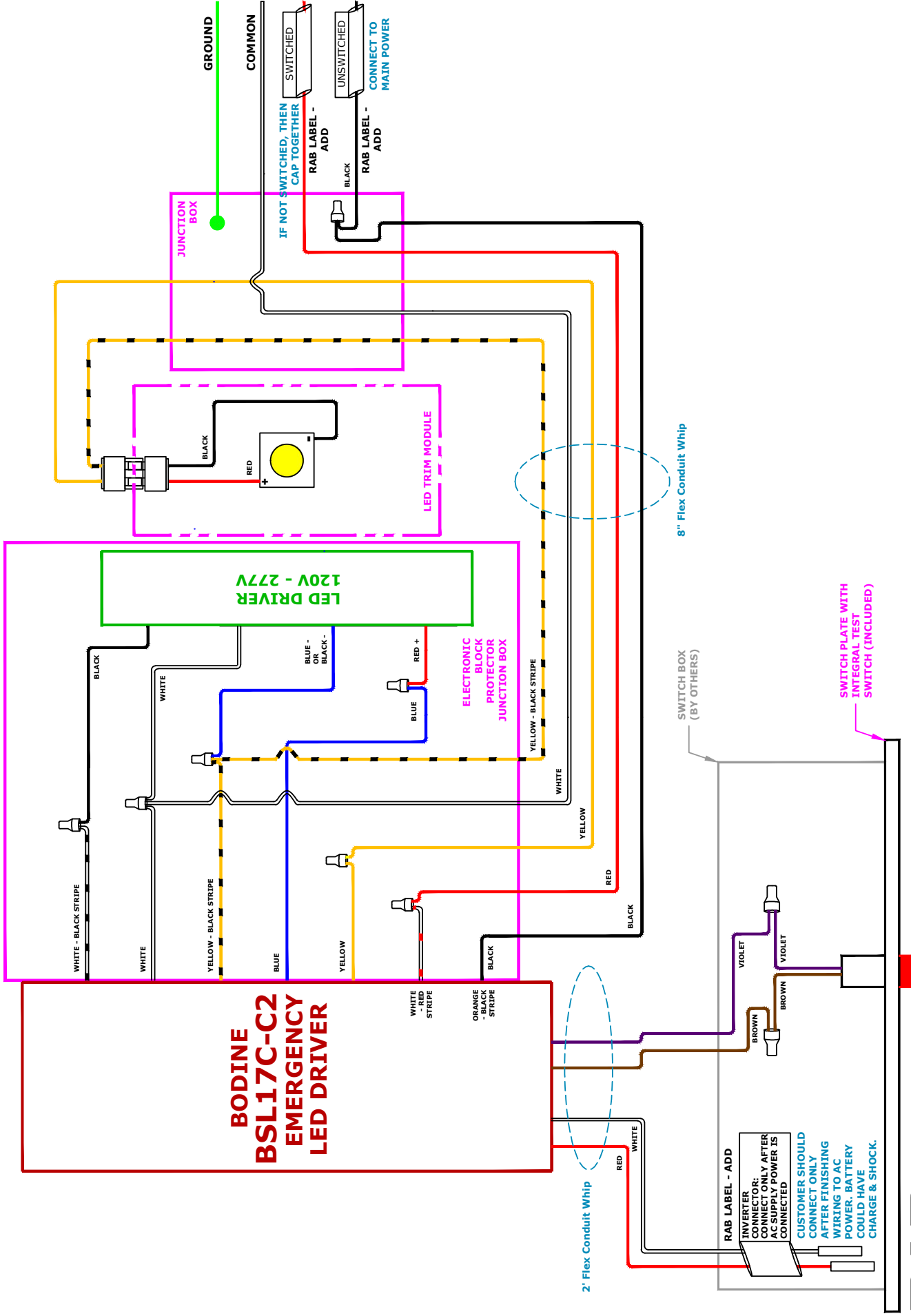

WIRING DIAGRAM for EMERGENCY OPERATION at 120V - 277V with Thermal Protector

Emergency Ballast and AC Ballast must be fed from the same circuit

