



Color: Bronze

Weight: 4.6 lbs

**Project:**

**Type:**

**Prepared By:**

**Date:**

### Driver Info

Type	Constant Current
120V	0.17A
208V	0.11A
240V	0.10A
277V	0.09A
Input Watts	20.6W

### LED Info

Watts	18W
Color Temp	4000K (Neutral)
Color Accuracy	71 CRI
L70 Lifespan	100,000 Hours
Lumens	2,269
Efficacy	110.1 lm/W

## Technical Specifications

### Compliance

#### UL Listed:

Suitable for wet locations. Suitable for ground mounting.

#### IESNA LM-79 & LM-80 Testing:

RAB LED luminaires and LED components have been tested by an independent laboratory in accordance with IESNA LM-79 and LM-80.

### Optical

#### NEMA Type:

NEMA Beam Spread of 2H x 2V

### LED Characteristics

#### LEDs:

Multi-chip, high-output, long-life LEDs

#### Color Stability:

RAB LEDs exceed industry standards for chromatic stability

### Color Uniformity:

RAB's range of Correlated Color Temperature follows the guidelines of the American National Standard for Specifications for the Chromaticity of Solid State Lighting (SSL) Products, ANSI C78.377-2017.

### Construction

#### Cold Weather Starting:

Minimum starting temperature is -40°C (-40°F)

#### Thermal Management:

Superior heat sinking with external Air-Flow fins

#### Housing:

Precision die-cast aluminum housing, lens frame and mounting arm

#### Reflector:

Semi-specular, vacuum-metalized polycarbonate

### Mounting:

Heavy-duty mounting arm with "O" ring seal & stainless steel screws

#### Gaskets:

High-temperature silicone gaskets

#### Finish:

Our environmentally friendly polyester powder coatings are formulated for high-durability and long-lasting color

#### Green Technology:

Mercury and UV free. RoHS-compliant components.

## Technical Specifications (continued)

### Other

#### Warranty:

RAB warrants that our LED products will be free from defects in materials and workmanship for a period of five (5) years from the date of delivery to the end user, including coverage of light output, color stability, driver performance and fixture finish. RAB's warranty is subject to all terms and conditions found at [rablighting.com/warranty](http://rablighting.com/warranty).

#### Buy American Act Compliance:

RAB values USA manufacturing! Upon request, RAB may be able to manufacture this product to be compliant with the Buy American Act (BAA). Please contact customer service to request a quote for the product to be made BAA compliant.

### Electrical

#### Driver:

Constant Current, 500mA, Class 2 120-277V with 4kV surge protection, 120V: 0.17A, 208V: 0.11A, 240V: 0.10A, 277V: 0.09A, 50/60Hz THD < 20%, Power Factor: 99%

#### THD:

10.06% at 120V, 19.05% at 277V

### Listings

#### DLC Listed:

This product is on the Design Lights Consortium (DLC) Qualified Products List and is eligible for rebates from DLC Member Utilities. DLC Product Code: P9Y88TEBQ

### Dimensions

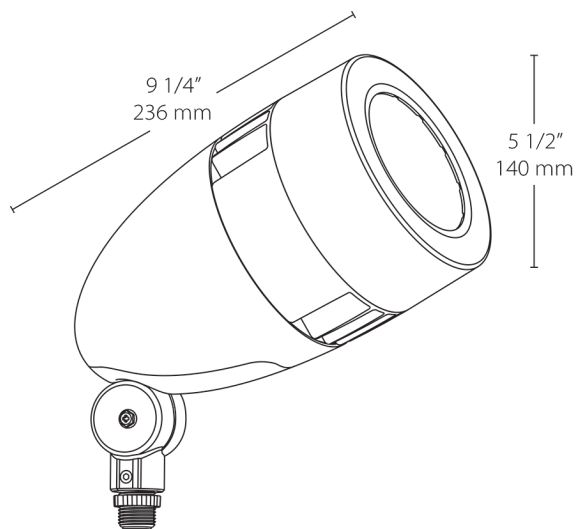

### Features

- 80% energy savings vs. PAR floods
- Mount on junction box or on RAB Mighty Post
- Patent-pending "Air-Flow" technology
- 5-Year, No-Compromise Warranty

### Ordering Matrix

Family	Wattage	Color Temp	Finish	Driver Options
HNLED	18	N	A	
	18 = 18W 26 = 26W	Blank = 5000K (Cool) N = 4000K (Neutral) Y = 3000K (Warm)	A = Bronze W = White B = Black VG = Verde Green	Blank = No Option /D10 = 0-10V Dimming /480 = 480V (Only available for 26W)