

# SSS-S SERIES POLES

SQUARE STRAIGHT STEEL

|       |      |
|-------|------|
| Cat.# |      |
| Job   | Type |



Approvals

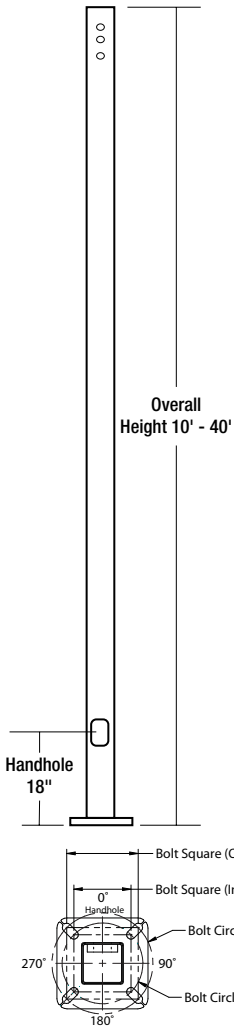

### APPLICATIONS

- Lighting installations for side and top mounting of luminaires with effective projected area (EPA) not exceeding maximum allowable loading of the specified pole in its installed geographic location

### CONSTRUCTION

- **SHAFT:** One-piece straight steel with square cross section, flat sides and minimum 0.238" radius on all corners; Minimum yield of 46,000 psi (ASTM-A500, Grade B); Longitudinal weld seam to appear flush with shaft side wall; Steel base plate with axial bolt circle slots welded flush to pole shaft having minimum yield of 36,000 psi (ASTM A36)
- **BASE COVER:** Two-piece square aluminum base cover included standard
- **POLE CAP:** Pole shaft supplied with removable cover when applicable; Tenon and post-top configurations also available
- **HAND HOLE:** Rectangular 3x5 steel hand hole frame (2.38" x 4.38" opening); Mounting provisions for grounding lug located behind gasketed cover
- **ANCHOR BOLTS:** Four galvanized anchor bolts provided per pole with minimum yield of 55,000 psi (ASTM F1554). Galvanized hardware with two washers and two nuts per bolt for leveling

### FINISH

- Durable thermoset polyester powder coat paint finish with nominal 3.0 mil thickness
- Powder paint prime applied over "white metal" steel substrate cleaned via mechanical shot blast method
- Decorative finish coat available in seven standard colors; Custom colors available; RAL number preferable; Internal protective coating available

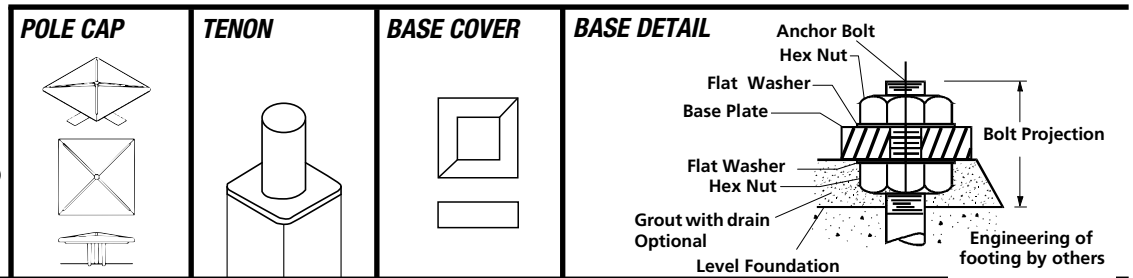

### ORDERING INFORMATION

Reference page 2 for available configurations

ORDERING EXAMPLE:

**SSS-S - 25 - 40 - A/B/C - 2L - S2 - DB - UL**

| SERIES  | HEIGHT                           | SHAFT                            | THICKNESS                        | MOUNTING  | DRILL PATTERN                                  | FINISH  | OPTIONS   |
|---|----------------------------------|----------------------------------|----------------------------------|---|--|---|---|
| <b>SSS-S</b> Square Straight Steel Pole Spaulding | Reference page 2 Ordering matrix | Reference page 2 Ordering matrix | Reference page 2 Ordering matrix | <b>1</b> Single arm mount<br><b>2</b> Two fixtures at 180°<br><b>2L</b> Two fixtures at 90°<br><b>3T</b> Three fixtures at 90°<br><b>4</b> Four fixtures at 90°<br><b>TA</b> Tenon (2.375" OD)<br><b>TB</b> Tenon (2.875" OD)<br><b>TC</b> Tenon (3.5" OD)<br><b>TR<sup>1</sup></b> Removable Tenon (2.375 x 4.25)<br><b>OT</b> No drilling (includes pole cap) | <b>S2</b> Spaulding #2 2 bolt 3.5" pattern<br> | <b>DB</b> Dark Bronze<br><b>BL</b> Black<br><b>WH</b> White<br><b>GR</b> Gray<br><b>PS</b> Platinum Silver<br><b>RD</b> Red (premium color)<br><b>FG</b> Forest Green (premium color)<br><b>CC</b> Custom Color | <b>HSC</b> Internal Coating (Hubbell Seal)<br><b>GF<sup>2</sup></b> 20 Amp GFCI Receptacle and Cover<br><b>EHH<sup>2</sup></b> Extra Handhole<br><b>C05<sup>2</sup></b> .5" Coupling<br><b>C07<sup>2</sup></b> .75" Coupling<br><b>C20<sup>2</sup></b> 2" Coupling<br><b>MPB<sup>2</sup></b> Mid-pole Luminaire Bracket<br><b>VM2</b> 2nd mode vibration damper<br><b>LAB</b> Less Anchor Bolts<br><b>UL</b> UL Certified |

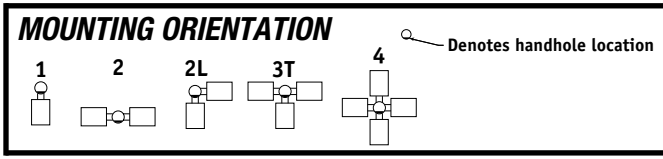

### ACCESSORIES- Order Separately

| Catalog Number         | Description               |
|------------------------|---------------------------|
| <b>VM1<sup>3</sup></b> | 1st mode vibration damper |
| <b>VM2SXX</b>          | 2nd mode vibration damper |

- 1 Removable tenon used in conjunction with side arm mounting. First specify desired arm configuration followed by the "TR" notation. Example: **SSS-S-25-40-A-1-S2-TR-DB**
- 2 Specify option location using logic found on page 2 (**Option Orientation**)
- 3 VM1 required on poles 20" and taller with EPA of less than 1.



Spaulding Lighting • 701 Millennium Boulevard • Greenville, SC 29607 • Phone: 864-678-1000  
 Due to our continued efforts to improve our products, product specifications are subject to change without notice.



## ORDERING INFORMATION Cont.

| Catalog Number      | Height |        | Nominal Shaft Dimensions | Wall Thickness | Bolt Circle (suggested) | Bolt Circle (range) | Bolt Square (range) | Base Plate Square | Anchor bolt size  | Bolt Projection | Pole weight |
|---------------------|--------|--------|--------------------------|----------------|-------------------------|---------------------|---------------------|-------------------|-------------------|-----------------|-------------|
|                     | Feet   | Meters |                          |                |                         |                     |                     |                   |                   |                 |             |
| SSS-S-10-40-A-XX-XX | 10     | 3.0    | 4" square                | 0.125"         | 9"                      | 8" - 10"            | 5.66" - 7.07"       | 9"                | 3/4" x 30" x 3"   | 3.5             | 77          |
| SSS-S-12-40-A-XX-XX | 12     | 3.7    | 4" square                | 0.125"         | 9"                      | 8" - 10"            | 5.66" - 7.07"       | 9"                | 3/4" x 30" x 3"   | 3.5             | 90          |
| SSS-S-14-40-A-XX-XX | 14     | 4.3    | 4" square                | 0.125"         | 9"                      | 8" - 10"            | 5.66" - 7.07"       | 9"                | 3/4" x 30" x 3"   | 3.5             | 103         |
| SSS-S-16-40-A-XX-XX | 16     | 4.9    | 4" square                | 0.125"         | 9"                      | 8" - 10"            | 5.66" - 7.07"       | 9"                | 3/4" x 30" x 3"   | 3.5             | 116         |
| SSS-S-18-40-A-XX-XX | 18     | 5.5    | 4" square                | 0.125"         | 9"                      | 8" - 10"            | 5.66" - 7.07"       | 9"                | 3/4" x 30" x 3"   | 3.5             | 129         |
| SSS-S-20-40-A-XX-XX | 20     | 6.1    | 4" square                | 0.125"         | 9"                      | 8" - 10"            | 5.66" - 7.07"       | 9"                | 3/4" x 30" x 3"   | 3.5             | 142         |
| SSS-S-25-40-A-XX-XX | 25     | 7.6    | 4" square                | 0.125"         | 9"                      | 8" - 10"            | 5.66" - 7.07"       | 9"                | 3/4" x 30" x 3"   | 3.5             | 175         |
| SSS-S-14-40-B-XX-XX | 14     | 4.3    | 4" square                | .188"          | 11"                     | 10" - 12"           | 7.07" - 8.48"       | 10.50"            | 3/4" x 30" x 3"   | 3.5             | 152         |
| SSS-S-16-40-B-XX-XX | 16     | 4.9    | 4" square                | .188"          | 11"                     | 10" - 12"           | 7.07" - 8.48"       | 10.50"            | 3/4" x 30" x 3"   | 3.5             | 171         |
| SSS-S-18-40-B-XX-XX | 18     | 5.5    | 4" square                | .188"          | 11"                     | 10" - 12"           | 7.07" - 8.48"       | 10.50"            | 3/4" x 30" x 3"   | 3.5             | 190         |
| SSS-S-20-40-B-XX-XX | 20     | 6.1    | 4" square                | .188"          | 11"                     | 10" - 12"           | 7.07" - 8.48"       | 10.50"            | 3/4" x 30" x 3"   | 3.5             | 209         |
| SSS-S-25-40-B-XX-XX | 25     | 7.6    | 4" square                | .188"          | 11"                     | 10" - 12"           | 7.07" - 8.48"       | 10.50"            | 3/4" x 30" x 3"   | 3.5             | 257         |
| SSS-S-30-40-B-XX-XX | 30     | 9.1    | 4" square                | .188"          | 11"                     | 10" - 12"           | 7.07" - 8.48"       | 10.50"            | 3/4" x 30" x 3"   | 3.5             | 304         |
| SSS-S-16-50-B-XX-XX | 16     | 4.9    | 5" square                | .188"          | 11"                     | 10.25" - 13.25"     | 7.25" - 9.37"       | 11.50"            | 1" x 36" x 4"     | 4.5             | 219         |
| SSS-S-18-50-B-XX-XX | 18     | 5.5    | 5" square                | .188"          | 11"                     | 10.25" - 13.25"     | 7.25" - 9.37"       | 11.50"            | 1" x 36" x 4"     | 4.5             | 243         |
| SSS-S-20-50-B-XX-XX | 20     | 6.1    | 5" square                | .188"          | 11"                     | 10.25" - 13.25"     | 7.25" - 9.37"       | 11.50"            | 1" x 36" x 4"     | 4.5             | 267         |
| SSS-S-25-50-B-XX-XX | 25     | 7.6    | 5" square                | .188"          | 11"                     | 10.25" - 13.25"     | 7.25" - 9.37"       | 11.50"            | 1" x 36" x 4"     | 4.5             | 327         |
| SSS-S-30-50-B-XX-XX | 30     | 9.1    | 5" square                | .188"          | 11"                     | 10.25" - 13.25"     | 7.25" - 9.37"       | 11.50"            | 1" x 36" x 4"     | 4.5             | 387         |
| SSS-S-25-50-C-XX-XX | 25     | 7.6    | 5" square                | .25"           | 11"                     | 10.25" - 13.25"     | 7.25" - 9.37"       | 11.50"            | 1" x 36" x 4"     | 4.5             | 427         |
| SSS-S-30-50-C-XX-XX | 30     | 9.1    | 5" square                | .25"           | 11"                     | 10.25" - 13.25"     | 7.25" - 9.37"       | 11.50"            | 1" x 36" x 4"     | 4.5             | 507         |
| SSS-S-20-60-B-XX-XX | 20     | 6.1    | 6" square                | .188"          | 12"                     | 11.00" - 13.25"     | 7.81" - 9.37"       | 12.25"            | 1-1/4" x 42" x 6" | 5.0             | 329         |
| SSS-S-25-60-B-XX-XX | 25     | 7.6    | 6" square                | .188"          | 12"                     | 11.00" - 13.25"     | 7.81" - 9.37"       | 12.25"            | 1-1/4" x 42" x 6" | 5.0             | 404         |
| SSS-S-30-60-B-XX-XX | 30     | 9.1    | 6" square                | .188"          | 12"                     | 11.00" - 13.25"     | 7.81" - 9.37"       | 12.25"            | 1-1/4" x 42" x 6" | 5.0             | 479         |
| SSS-S-35-60-B-XX-XX | 35     | 10.7   | 6" square                | .188"          | 12"                     | 11.00" - 13.25"     | 7.81" - 9.37"       | 12.25"            | 1-1/4" x 42" x 6" | 5.0             | 554         |
| SSS-S-40-60-B-XX-XX | 40     | 12.2   | 6" square                | .188"          | 12"                     | 11.00" - 13.25"     | 7.81" - 9.37"       | 12.25"            | 1-1/4" x 42" x 6" | 5.0             | 629         |
| SSS-S-30-60-C-XX-XX | 30     | 9.1    | 6" square                | .25"           | 12"                     | 11.00" - 13.25"     | 7.81" - 9.37"       | 12.25"            | 1-1/4" x 42" x 6" | 5.0             | 614         |
| SSS-S-35-60-C-XX-XX | 35     | 10.7   | 6" square                | .25"           | 12"                     | 11.00" - 13.25"     | 7.81" - 9.37"       | 12.25"            | 1-1/4" x 42" x 6" | 5.0             | 712         |
| SSS-S-40-60-C-XX-XX | 40     | 12.2   | 6" square                | .25"           | 12"                     | 11.00" - 13.25"     | 7.81" - 9.37"       | 12.25"            | 1-1/4" x 42" x 6" | 5.0             | 809         |

NOTE Factory supplied template must be used when setting anchor bolts. Hubbell Lighting will deny any claim for incorrect anchorage placement resulting from failure to use factory supplied template and anchor bolts.

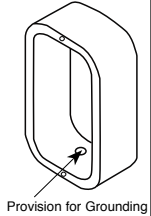
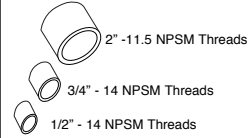
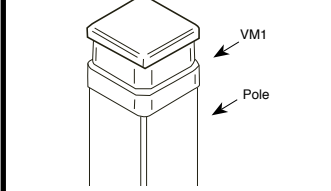
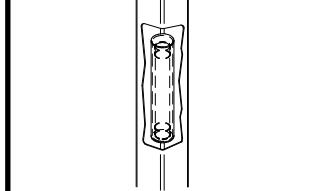
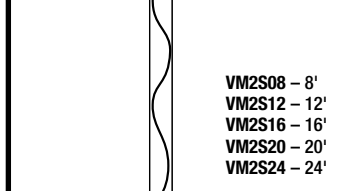
|   |  |   |   |  |
|---|--|---|---|--|
| <p><b>EHH - EXTRA HANDHOLE</b></p>  <p>Provision for Grounding</p> | <p><b>C05 - C07 - C20 - COUPLING</b></p>  <p>2" - 11.5 NPSM Threads<br/>3/4" - 14 NPSM Threads<br/>1/2" - 14 NPSM Threads</p> | <p><b>VM1 - VIBRATION DAMPER 1ST MODE</b></p>  <p>Field Installed Pole Top damper designed to reduce pole top deflection or sway. VM1 is required for pole systems 20' and taller with a total EPA of 1.0 or less.</p> | <p><b>VM2 - VIBRATION DAMPER 2ND MODE</b></p>  <p>Factory installed, internal damper designed to alter pole resonance to reduce movement and material fatigue caused by 2nd mode vibration.</p> | <p><b>VM2SXX - VIBRATION DAMPER 2ND MODE</b></p>  <p>VM2S08 - 8'<br/>VM2S12 - 12'<br/>VM2S16 - 16'<br/>VM2S20 - 20'<br/>VM2S24 - 24'</p> <p>Field installed, internal damper designed to alter pole resonance to reduce movement and material fatigue caused by 2nd mode vibration.</p> |
|---|--|---|---|--|

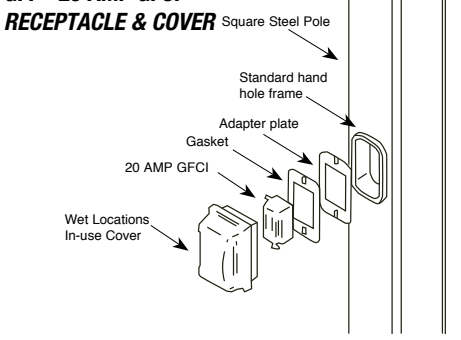
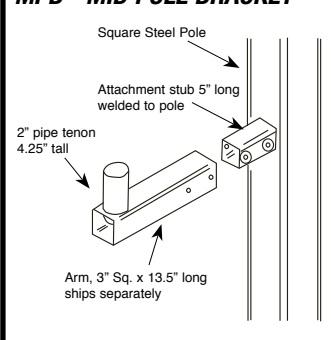
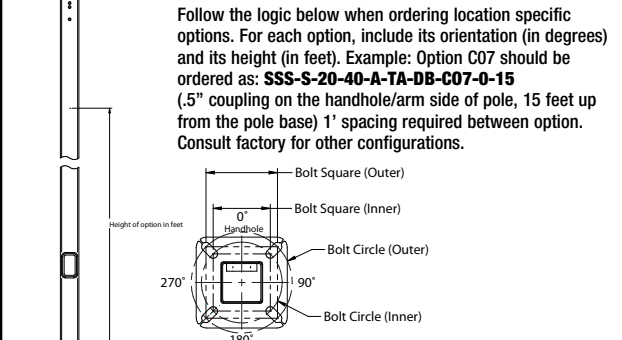
|  |   |  |
|--|---|--|
| <p><b>GFI - 20 AMP GFCI RECEPTACLE &amp; COVER</b></p>  <p>Square Steel Pole<br/>Standard hand hole frame<br/>Adapter plate<br/>Gasket<br/>20 AMP GFCI<br/>Wet Locations In-use Cover</p> | <p><b>MPB - MID POLE BRACKET</b></p>  <p>Square Steel Pole<br/>Attachment stub 5" long welded to pole<br/>2" pipe tenon 4.25" tall<br/>Arm, 3" Sq. x 13.5" long ships separately</p> | <p><b>OPTION ORIENTATION</b></p> <p>Follow the logic below when ordering location specific options. For each option, include its orientation (in degrees) and its height (in feet). Example: Option C07 should be ordered as: <b>SSS-S-20-40-A-TA-DB-C07-0-15</b> (.5" coupling on the handhole/arm side of pole, 15 feet up from the pole base) 1' spacing required between option. Consult factory for other configurations.</p>  <p>Height of option in feet<br/>Bolt Square (Outer)<br/>Bolt Square (Inner)<br/>Bolt Circle (Outer)<br/>Bolt Circle (Inner)<br/>0°<br/>90°<br/>180°<br/>270°</p> |
|--|---|--|

For more information about pole vibration and vibration dampers, please consult [http://cdn.spaudlinglighting.com/content/products/literature/literature\\_files/Pole\\_Wind\\_Induced\\_Flyer\\_HLOI0022.pdf](http://cdn.spaudlinglighting.com/content/products/literature/literature_files/Pole_Wind_Induced_Flyer_HLOI0022.pdf)  
Due to our continued efforts to improve our products, product specifications are subject to change without notice.



**ASCE7-05 WIND MAP**

**FLORIDA REGION WIND MAP**

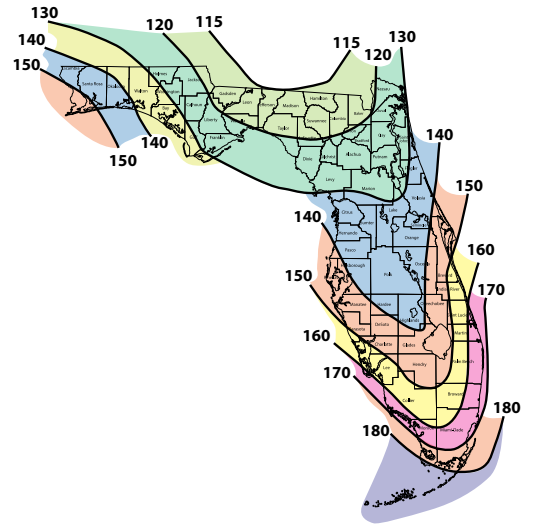
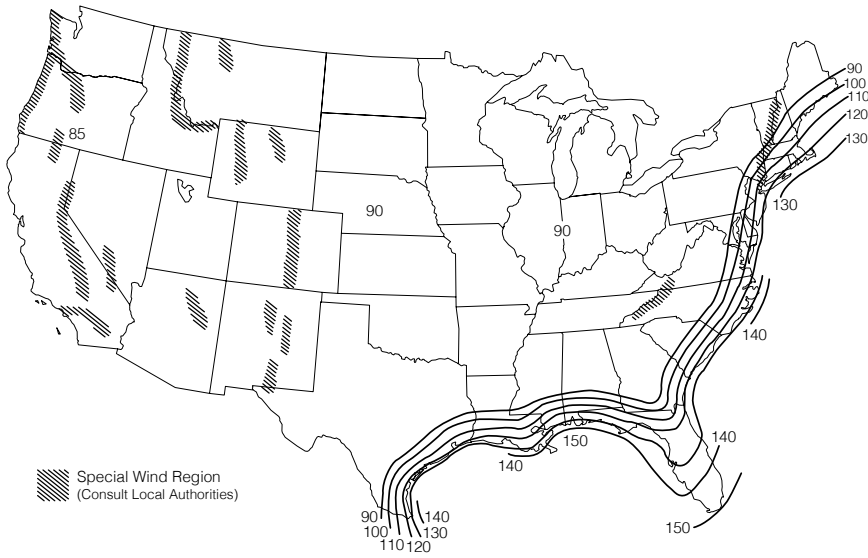

**HAWAII – 105 mph**  
**PUERTO RICO – 145 mph**

• Florida region wind map above is based upon 3-second gust winds and the 2010 Florida Building Code

| ASCE 7-05 wind map EPA Load Rating - 3 second gust wind speeds |      |      |      |      |      |      |      |
|--|------|------|------|------|------|------|------|
| Catalog Number   | 85   | 90   | 100  | 110  | 120  | 105  | 145  |
| SSS-S-10-40-A  | 25.0 | 25.0 | 25.0 | 20.6 | 17.0 | 22.8 | 11.0 |
| SSS-S-12-40-A  | 25.0 | 25.0 | 20.0 | 16.1 | 13.2 | 18.0 | 8.1  |
| SSS-S-14-40-A  | 23.1 | 20.4 | 16.1 | 12.8 | 10.2 | 14.3 | 5.9  |
| SSS-S-16-40-A  | 19.0 | 16.7 | 13.0 | 10.1 | 7.9  | 11.5 | 4.1  |
| SSS-S-18-40-A  | 15.6 | 13.6 | 10.0 | 7.8  | 5.9  | 9.0  | 2.6  |
| SSS-S-20-40-A  | 12.7 | 10.9 | 7.9  | 5.9  | 4.2  | 6.9  | 1.3  |
| SSS-S-25-40-A  | 7.3  | 5.9  | 3.8  | 2.1  | 0.8  | 2.9  | NR   |
| SSS-S-14-40-B  | 25.0 | 25.0 | 23.3 | 18.6 | 15.1 | 20.8 | 9.2  |
| SSS-S-16-40-B  | 25.0 | 24.9 | 19.4 | 15.4 | 12.3 | 17.3 | 7.2  |
| SSS-S-18-40-B  | 24.0 | 20.8 | 16.1 | 12.5 | 9.8  | 14.2 | 5.3  |
| SSS-S-20-40-B  | 20.2 | 17.5 | 13.2 | 10.1 | 7.7  | 11.6 | 3.8  |
| SSS-S-25-40-B  | 12.8 | 11.0 | 7.9  | 5.5  | 3.7  | 6.7  | 0.7  |
| SSS-S-30-40-B  | 8.0  | 6.6  | 4.1  | 2.2  | 0.8  | 3.1  | NR   |
| SSS-S-16-50-B  | 25.0 | 25.0 | 25.0 | 24.8 | 20.1 | 25.0 | 12.3 |
| SSS-S-18-50-B  | 25.0 | 25.0 | 25.0 | 20.4 | 16.4 | 22.9 | 9.6  |
| SSS-S-20-50-B  | 25.0 | 25.0 | 21.3 | 16.7 | 13.2 | 18.9 | 7.2  |
| SSS-S-25-50-B  | 20.7 | 17.8 | 13.3 | 9.8  | 7.2  | 11.5 | 2.6  |
| SSS-S-30-50-B  | 13.5 | 11.3 | 7.7  | 4.9  | 2.8  | 6.2  | NR   |
| SSS-S-25-50-C  | 25.0 | 25.0 | 19.4 | 15.1 | 11.7 | 17.1 | 6.0  |
| SSS-S-30-50-C  | 20.1 | 17.3 | 12.7 | 9.3  | 6.6  | 10.9 | 2.1  |
| SSS-S-20-60-B  | 25.0 | 25.0 | 25.0 | 25.0 | 20.2 | 25.0 | 11.5 |
| SSS-S-25-60-B  | 25.0 | 25.0 | 20.6 | 15.6 | 11.8 | 18.0 | 5.2  |
| SSS-S-30-60-B  | 21.4 | 18.1 | 12.9 | 8.8  | 5.7  | 10.7 | NR   |
| SSS-S-35-60-B  | 14.0 | 11.3 | 6.9  | 3.6  | 1.0  | 5.2  | NR   |
| SSS-S-40-60-B  | 8.1  | 5.8  | 2.2  | NR   | NR   | NR   | NR   |
| SSS-S-30-60-C  | 24.3 | 20.5 | 14.6 | 10.2 | 6.8  | 12.2 | 1.3  |
| SSS-S-35-60-C  | 16.6 | 13.5 | 8.6  | 4.9  | 2.1  | 6.6  | NR   |
| SSS-S-40-60-C  | 10.6 | 7.9  | 3.7  | 0.6  | NR   | 2.1  | NR   |

| Florida Building Code 2010 EPA Load Rating - 3 second gust wind speeds |      |      |      |      |      |      |      |      |
|--|------|------|------|------|------|------|------|------|
| Catalog Number   | 115  | 120  | 130  | 140  | 150  | 160  | 170  | 180  |
| SSS-S-10-40-A  | 25.0 | 25.0 | 25.0 | 25.0 | 21.4 | 18.4 | 15.9 | 13.9 |
| SSS-S-12-40-A  | 25.0 | 25.0 | 23.6 | 19.8 | 16.7 | 14.2 | 12.1 | 10.4 |
| SSS-S-14-40-A  | 25.0 | 23.1 | 19.0 | 15.7 | 13.1 | 10.9 | 9.1  | 7.6  |
| SSS-S-16-40-A  | 20.8 | 18.7 | 15.2 | 12.3 | 10.1 | 8.2  | 6.7  | 5.4  |
| SSS-S-18-40-A  | 16.8 | 15.0 | 11.9 | 9.4  | 7.5  | 5.9  | 4.5  | 3.4  |
| SSS-S-20-40-A  | 13.6 | 11.9 | 9.2  | 7.1  | 5.3  | 3.9  | 2.7  | 1.7  |
| SSS-S-25-40-A  | 7.4  | 6.2  | 4.1  | 2.5  | 1.1  | NR   | NR   | NR   |
| SSS-S-14-40-B  | 25.0 | 23.6 | 19.4 | 16.1 | 13.4 | 11.2 | 9.4  | 7.8  |
| SSS-S-16-40-B  | 21.4 | 19.2 | 15.6 | 12.7 | 10.4 | 8.5  | 6.9  | 5.6  |
| SSS-S-18-40-B  | 17.2 | 15.4 | 12.2 | 9.7  | 7.7  | 6.1  | 4.7  | 3.6  |
| SSS-S-20-40-B  | 13.9 | 12.3 | 9.5  | 7.3  | 5.5  | 4.1  | 2.9  | 1.9  |
| SSS-S-25-40-B  | 7.7  | 6.4  | 4.3  | 2.6  | 1.3  | NR   | NR   | NR   |
| SSS-S-30-40-B  | 3.2  | 2.1  | NR   | NR   | NR   | NR   | NR   | NR   |
| SSS-S-16-50-B  | 25.0 | 25.0 | 25.0 | 25.0 | 25.0 | 21.4 | 18.2 | 15.5 |
| SSS-S-18-50-B  | 25.0 | 25.0 | 25.0 | 24.4 | 20.4 | 17.0 | 14.2 | 11.9 |
| SSS-S-20-50-B  | 25.0 | 25.0 | 24.4 | 19.9 | 16.3 | 13.4 | 11.0 | 8.9  |
| SSS-S-25-50-B  | 21.8 | 19.3 | 15.0 | 11.5 | 8.8  | 6.5  | 4.7  | 3.1  |
| SSS-S-30-50-B  | 13.7 | 11.7 | 8.2  | 5.5  | 3.3  | 1.5  | NR   | NR   |
| SSS-S-25-50-C  | 21.8 | 19.3 | 15.0 | 11.5 | 8.8  | 6.5  | 4.7  | 3.1  |
| SSS-S-30-50-C  | 13.7 | 11.7 | 8.2  | 5.5  | 3.3  | 1.5  | NR   | NR   |
| SSS-S-20-60-B  | 25.0 | 25.0 | 25.0 | 21.9 | 17.8 | 14.5 | 11.7 | 9.4  |
| SSS-S-25-60-B  | 23.8 | 20.9 | 16.1 | 12.3 | 9.2  | 6.6  | 4.5  | 2.8  |
| SSS-S-30-60-B  | 14.6 | 12.3 | 8.4  | 5.3  | 2.8  | 0.8  | NR   | NR   |
| SSS-S-35-60-B  | 7.5  | 5.6  | 2.4  | NR   | NR   | NR   | NR   | NR   |
| SSS-S-40-60-B  | 1.8  | NR   | NR   | NR   | NR   | NR   | NR   | NR   |
| SSS-S-30-60-C  | 14.6 | 12.3 | 8.4  | 5.3  | 2.8  | 0.8  | NR   | NR   |
| SSS-S-35-60-C  | 7.5  | 5.6  | 2.4  | NR   | NR   | NR   | NR   | NR   |
| SSS-S-40-60-C  | 1.8  | NR   | NR   | NR   | NR   | NR   | NR   | NR   |

---

## NOTES

### Wind-speed Website disclaimer:

Hubbell Lighting has no connection to the linked website and makes no representations as to its accuracy. While the information presented on this third-party website provides a useful starting point for analyzing wind conditions, Hubbell Lighting has not verified any of the information on this third party website and assumes no responsibility or liability for its accuracy. The material presented in the windspeed website should not be used or relied upon for any specific application without competent examination and verification of its accuracy, suitability and applicability by engineers or other licensed professionals. Hubbell Lighting Inc. does not intend that the use of this information replace the sound judgment of such competent professionals, having experience and knowledge in the field of practice, nor to substitute for the standard of care required of such professionals in interpreting and applying the results of the windspeed report provided by this website. Users of the information from this third party website assume all liability arising from such use. Use of the output of these referenced websites do not imply approval by the governing building code bodies responsible for building code approval and interpretation for the building site described by latitude/longitude location in the windspeed report. <http://windspeed.atcouncil.org>

- Allowable EPA, to determine max pole loading weight, multiply allowable EPA by 30 lbs.
- The tables for allowable pole EPA are based on the ASCE 7-05 Wind Map or the Florida Region Wind Map for the 2010 Florida Building Code. The Wind Maps are intended only as a general guide and cannot be used in conjunction with other maps. Always consult local authorities to determine maximum wind velocities, gusting and unique wind conditions for each specific application
- Allowable pole EPA for jobsite wind conditions must be equal to or greater than the total EPA for fixtures, arms, and accessories to be assembled to the pole. Responsibility lies with the specifier for correct pole selection. Installation of poles without luminaires or attachment of any unauthorized accessories to poles is discouraged and shall void the manufacturer's warranty
- Wind speeds and listed EPAs are for ground mounted installations. Poles mounted on structures (such as bridges and buildings) must consider vibration and coefficient of height factors beyond this general guide; Consult local and federal standards
- Wind Induced Vibration brought on by steady, unidirectional winds and other unpredictable aerodynamic forces are not included in wind velocity ratings. Consult Hubbell Lighting's Pole Vibration Application Guide for environmental risk factors and design considerations. [http://cdn.spauldinglighting.com/content/products/literature/literature\\_files/Pole\\_Wind\\_Induced\\_Flyer\\_HL010022.pdf](http://cdn.spauldinglighting.com/content/products/literature/literature_files/Pole_Wind_Induced_Flyer_HL010022.pdf)
- Extreme Wind Events like, Hurricanes, Typhoons, Cyclones, or Tornadoes may expose poles to flying debris, wind shear or other detrimental effects not included in wind velocity ratings

---

**Due to our continued efforts to improve our products, product specifications are subject to change without notice.**

---