

SIDES	BOTTOM
9 1/2" KNOCKOUTS	3 1/2" KNOCKOUTS
	2 1/2"-3/4" MOON KNOCKOUTS
2 PCS 8-32x1/2 Screws Installed	
Material: Steel-0.0625"-G60 Galvanized	

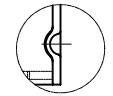

WELDING STYLE DETAIL VIEW D

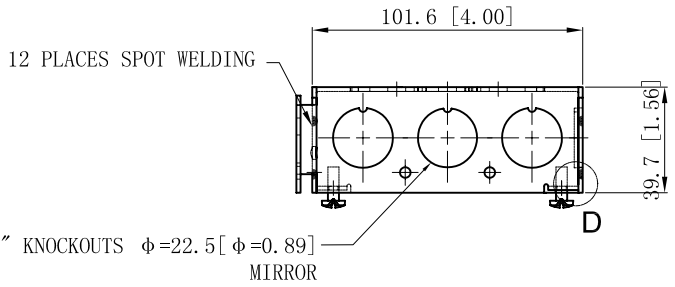
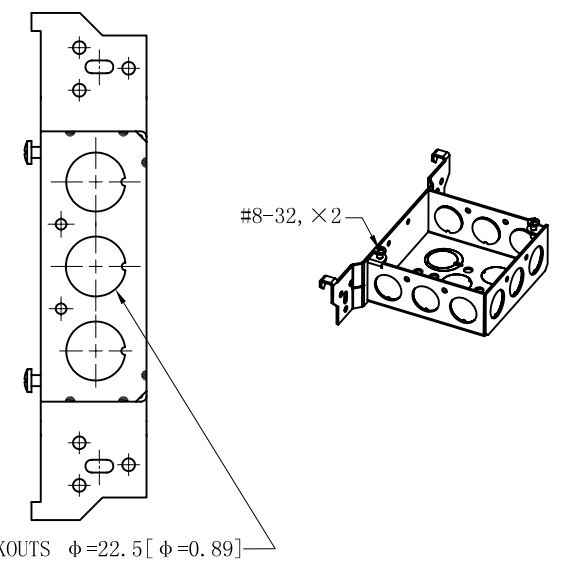
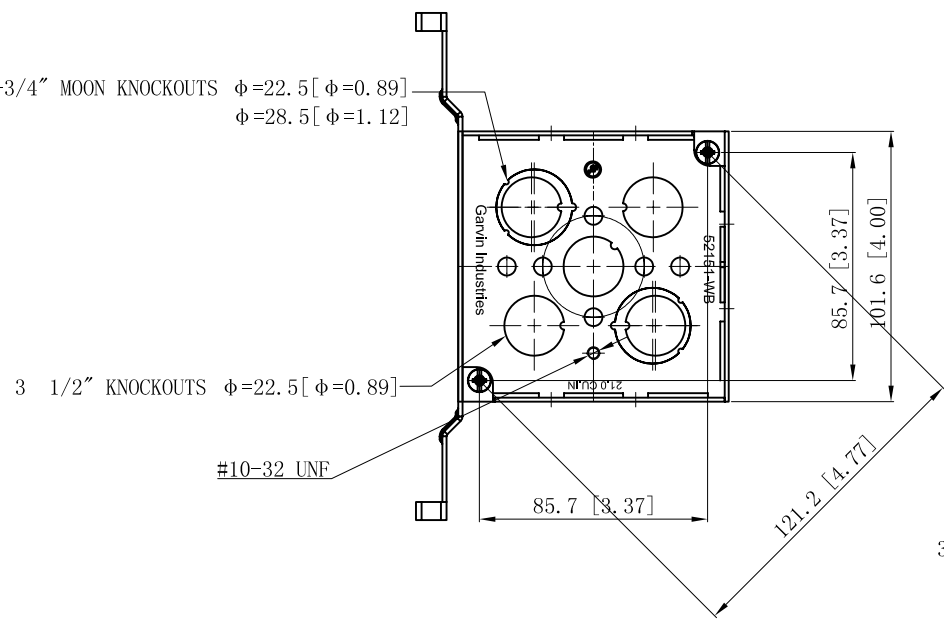
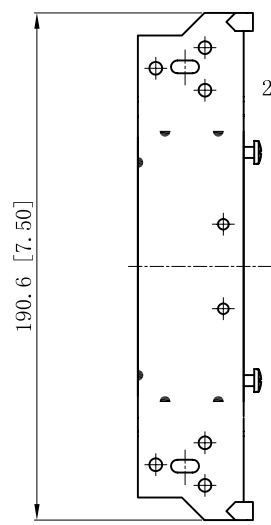

DESCRIPTION
TRADE REFERENCE TERMS

This data sheet is for reference only .GARVIN INDUSTRIES reserves the right to make changes to the design without prior notice.

STANDARD PACKING	TITLE		
	4" SQ. BRACKET BOXES (1-1/2" DEEP)		
25 PCS	SIZE	DWG NO.	REV
	A4	52151-WB	C
DATA SHEET			