



► Model AD-26, AD-27, AD-56 and AD-57

Atkinson Dynamics Wall Mount Intercom

Designed for single-channel, two-way indoor and outdoor communication applications, Wall-Mount Intercoms feature integrated volume control, TALK/LISTEN switch, corrosion resistant cast aluminum housing with rugged powder coat finish (Type 4X, IP56 enclosure), reliable 25-watt speaker, and balanced line output. These heavy duty units are UL listed, CSA Certified and Marine rated; and available in 12 or 24VDC and 120 or 240 VAC, 50/60Hz models.

FEATURES

- Available in 12 or 24VDC and 120 or 240VAC, 50/60Hz
- Heavy-duty industrial intercom for indoor or outdoor application
- Single channel, two-way communications
- Integrated volume control and Talk/Listen switch
- Balanced line output
- 25 watt speaker
- Cast aluminum housing with rugged powder coat finish
- Type 4X, IP56 enclosure
- UL listed, CSA Certified, Marine Rated

MODEL	VOLTAGE	OPERATING CURRENT	STANDBY CURRENT	FREQUENCY RESPONSE
AD-26	12VDC	1.47A	100mA	320Hz to 8.0Khz
AD-27	120VAC	240mA	83 mA	320Hz to 8.0Khz
AD-56	24VDC	1.65A	100mA	320Hz to 8.0Khz
AD-57	240VAC	127mA	83mA	320Hz to 8.0Khz

Atkinson Dynamics Wall Mount Intercom (AD-26, AD-27, AD-56 and AD-57)

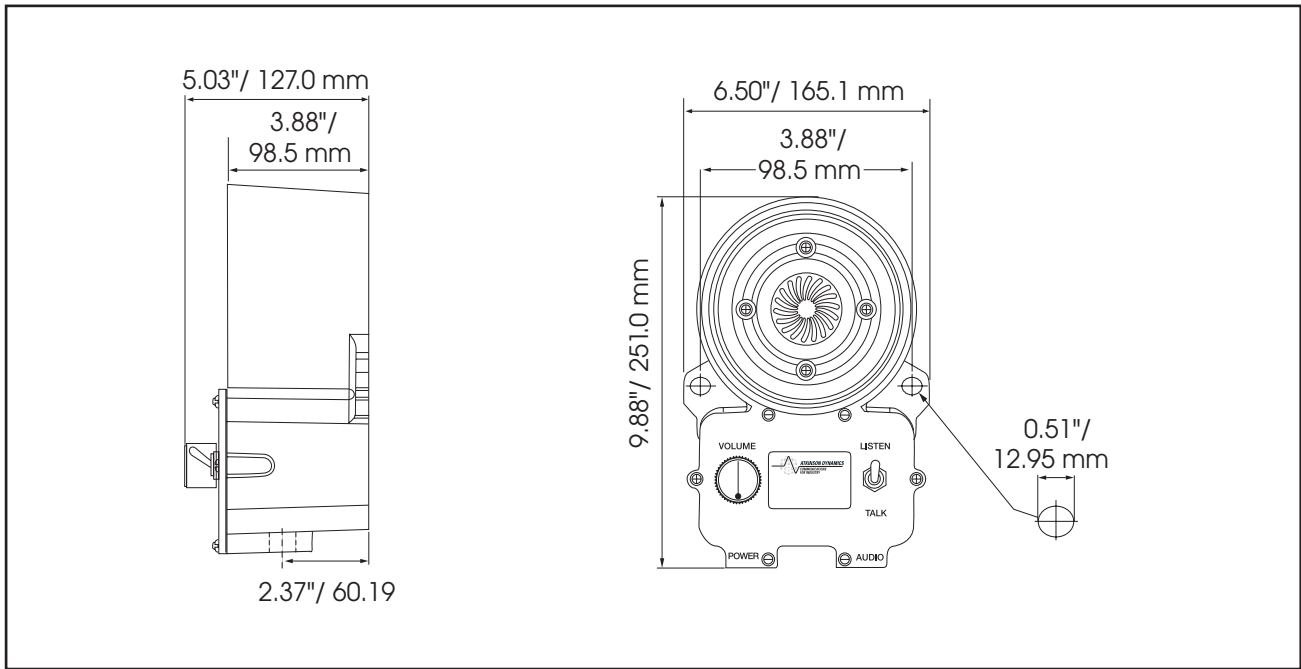

SPECIFICATIONS

Product Specifications		
Speaker Rating		30 watt
Operating Temperature	-31°F to 150°F	-50°C to 66°C
Net Weight	9 lbs	4.08 kg
Shipping Weight	11 lbs	4.99 kg
Dimensions:		
Height	9.88"	251.0 mm
Width	6.5"	165.1 mm
Depth	5.03"	127.0 mm

HOW TO ORDER

Step 1: Specify Base Model

- AD-26** (12VDC, Wall Mount Intercom)
- AD-27** (120VAC, Wall Mount Intercom)
- AD-56** (24VDC, Wall Mount Intercom)
- AD-57** (240VAC, Wall Mount Intercom)

Step 2: Add Optional Features

Example Part Number: AD-27A

OPTIONAL FEATURES

Note: Not all optional features are available for every model. Please consult factory to confirm model variation availability.

Description	Optional Feature
Call Button, Sends call tone to other intercoms on the same audio line	A
Master, controls Talk/Listen function of a Slave unit	C
Slave, allows hands free operation, default Talk mode	D
Remote Power, 120VAC unit can supply power to a 12VDC unit remotely	-1
Foot Pedal Ready, hands free operation of the Talk/Listen switch, pedal sold separately (ADFP)	-2
Auxiliary Signal, remote call button activated contact closure to activate remote strobe for additional attention gathering*	-3
Zoned System Remote, designed to be a remote unit in a zoned system. (Contact factory for zone design assistance)	-6
Noise Cancelling Microphone Ready, equipped with a jack for hand held microphone sold separately	-7
Pre-Amp Equipped, pre-amp to power a remote speaker	-8
Remote Volume Control Equipped, equipped with volume control for remote speaker	-M44

*LP3 strobe sold separately