



► Model 252

Vehicular Back-Up Alarms

Federal Signal's Model 252 back-up alarm is a solid state audible warning device enclosed in a weatherproof housing. The alarm produces a horn tone of 97 dBa @ 4 feet and sounds at approximately 60 times per minute with equal on and off pulses. Model 252 conforms to SAE (Society of Automotive Engineers) J994 Sound Level Type C.

Federal Signal's Model 252 housing is constructed of black glass-reinforced plastic and comes equipped with universal mountings for easy installation. When properly installed, this unit is weather-proof, dust-proof and not adversely affected by the steam cleaning of vehicles.

Model 252 is designed for use in a wide variety of vehicles that operate in populated areas — both indoors and out. This alarm is ideal for use on forklifts, tractors, waste disposal vehicles, dump trucks, earth moving equipment or any other vehicle that operates near people.

Federal Signal's Model 252 Vehicular Back-up Alarm is an economical life-safety device designed to prevent accidents.

FEATURES

- Operates within the 12-48VDC range used in most vehicles
- Produces 97 dBa @ 4'
- Rugged weather-proof housing
- Solid-state, epoxy-sealed electronics
- Universal mounting
- Conforms to SAE J994 sound level Type C requirements
- Type 4X enclosure

MODEL	VOLTAGE	OPERATING CURRENT	DECIBELS 4'
252-012-048	12-48VDC	0.20 amps	97

Vehicular Back-Up Alarm (252)

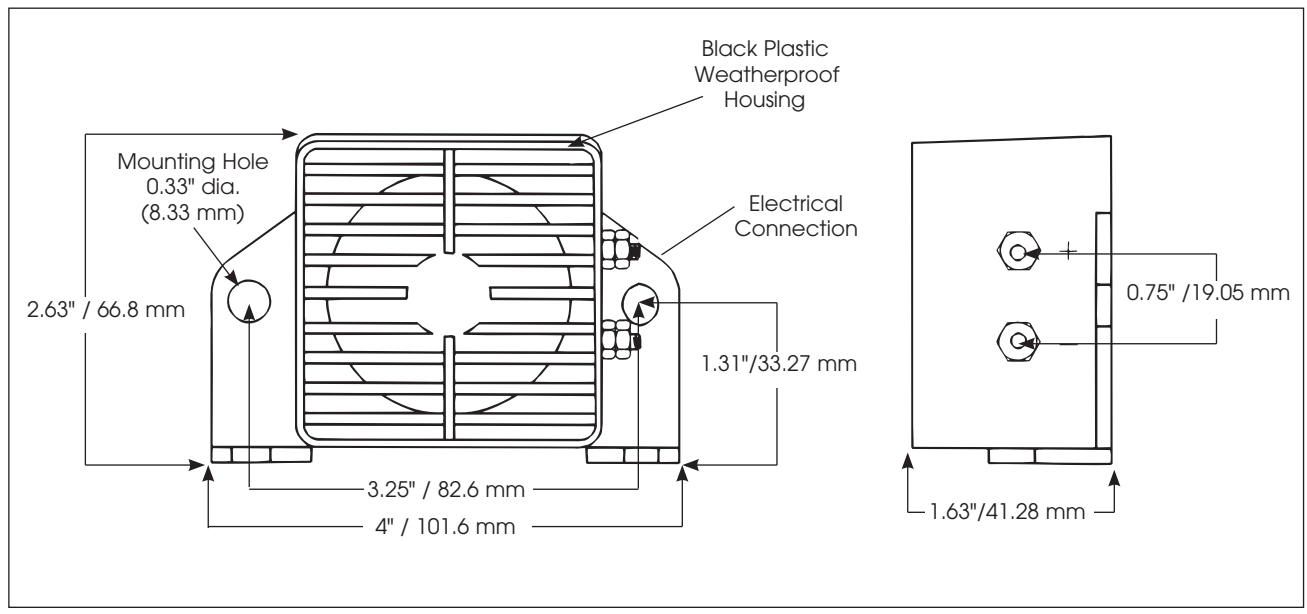

SPECIFICATIONS

Operating Temperature:	-40°F to 167°F	-40°C to 75°C
Net Weight:	0.3 lbs	7.62 kg
Shipping Weight:	0.4 lbs	10.16 kg
Height:	2.63"	66.8 mm
Width:	4.0"	101.6 mm
Depth:	1.63"	41.28 mm

HOW TO ORDER

Specify Model:
252-012-048 – Back-up alarm, 12-48VDC