

Installation Instructions for the Sure-Lites LEMSD Emergency Light with Self Diagnostics

IMPORTANT SAFEGUARDS

WHEN USING ELECTRICAL EQUIPMENT, BASIC SAFETY PRECAUTIONS SHOULD ALWAYS BE OBSERVED INCLUDING THE FOLLOWING

1. **READ AND FOLLOW ALL SAFETY INSTRUCTIONS**
2. Do not use outdoors.
3. Do not use in hazardous locations, or near gas or electric heaters.
4. Do not let power supply cords touch hot surfaces.
5. Do not use this equipment for other than the intended use.
6. Installation is to be performed only by qualified personnel.
7. Install in accordance with National Electric Code and local regulatory agency requirements.
8. The use of accessory equipment not recommended by the manufacturer may cause an unsafe condition.
9. Equipment should be mounted in locations and at heights where it will not readily be subjected to tampering by unauthorized personnel.
10. **SAVE THESE INSTRUCTIONS**

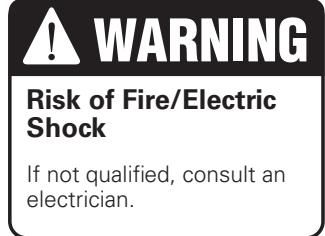

INSTALLATION

- Step 1** De-energize the circuit at the junction box (J-box) where the emergency light is to be installed.
- Step 2** Open the emergency light by inserting a screwdriver in the two slots at the bottom of the unit, then tipping the cover up off of the backplate.
- Step 3** To mount to a junction box - Drill out the appropriate mounting pattern and the wire pass hole in the backplate to fit the J-box being used.
- Step 4** To mount to conduit - Cut out the U shaped knockout on the cover using snips, then attach the 1/2" conduit hub to the backplate
- Step 5** Once the backplate is secured, the housing can be held in place during installation using the EZ Hang feature. (see Fig. 1)
- Step 6** Connect the incoming wires to the LEM power supply wires using the wire nuts provided. Connect the white wire to neutral. If using 120V, connect the black wire to the hot lead. If using 277V, connect the orange wire to the hot lead. Cap the unused lead. Secure the emergency light to the wall and/or junction box using installer supplied hardware.
- Step 7** Snap the cover onto the backplate.
- Step 8** Remove the EZ key battery disconnect.
- Step 9** Energize AC supply. The test button should illuminate, and LED heads will illuminate briefly when the test button is pushed.
- Step 10** Adjust the heads as needed. The LEM heads utilize a highly directional beam, so the head is adjustable in 3 axes, not the usual 2. (see Fig. 2)
- Step 11** If the LEM is to be powered down for an extended period after initial installation, replace the EZ Key. This will prevent the battery from discharging when AC power is removed. However, it will also prevent the battery from charging when AC power is restored, so it must be removed once the unit is ready for regular operation.

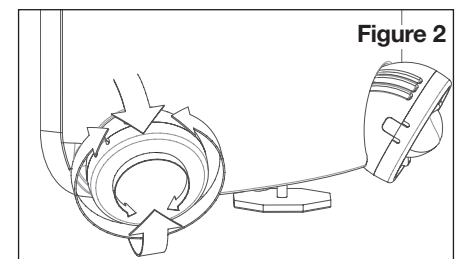
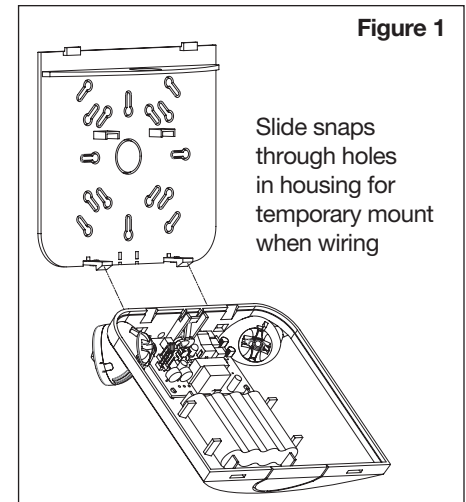

ACTIVATING TIME DELAY

The LEM has an integrated time delay circuit that allows them to remain in emergency mode 15 minutes after power is restored. To activate the time delay, remove the jumper on the circuit board labeled TDI/J1.

OPERATION

The Sure-Lites Eagle Eye Self Diagnostics is continuously monitoring your emergency fixture, and will signal any failure through the 3 color indicator LED.

INITIAL OPERATION

When the unit is first powered up, it will go into a 24 hour fast charge, indicated by the indicator LED pulsing green. Once the unit has fully charged, it will perform a self calibration, after which the LED will change to steady green, indicating the unit is fully charged and float charging the battery to maintain readiness.

AUTOMATIC TESTING

The unit will perform a battery capacity, lamp/LED, and charge circuit test every 30 days for 30 seconds. During this time, the indicator LED will change to a steady yellow. It will perform a full battery capacity (90 minute) test once per year. During this time, the indicator LED will change to a blinking yellow.

MANUAL TESTING

- 10 Second "Installation" test – Press and release the test button once during fast charge (blinking green) to initiate a 10 second quick test. The sign will switch to emergency mode for 10 seconds allowing the installer to verify proper installation of the unit, and the LED indicator will turn solid yellow.
- 30 Second Test - Press and release the test button once during float charge (steady green). The indicator LED will turn steady yellow to indicate the unit is performing a 30 second test of the batteries and lamps/LEDs.
- 90 Minute Test - Press and release the test button a second time during a 30 second test (steady yellow) to change to a 90 minute test. During this test, the LED indicator will change to blinking yellow, and the circuit will perform a full battery capacity, charge circuit, and LED test.
- Canceling Test – Press and release the test button during the 90 minute test (flashing yellow) to return the fixture to its original state (fast charge or float charge).

LASER TEST

The LEMSD is equipped with a Laser Test function, that allows the unit to be manually tested without the need to physically press the test button. Shining a laser pointer in the hole marked "LASER TEST" on the bottom of the unit has the same effect as a press and release of the test button.

CLEARING FAILURE CODES

- A battery failure (LED two blink red) can be cleared by replacing the battery. Disconnecting the battery and AC power, or performing a full 90 minute discharge, will reset the error code, however, it will return if the battery is faulty.
- Charge Circuit (LED three blink red) and lamp/LED failure (LED four blink red) will clear when the unit successfully passes a manual or automatic 30 second test.

INDICATORS

- LED Off - No power to unit, emergency mode.
- LED Steady Green - Unit is fully charged and is float charging the battery to maintain readiness.
- LED Green Pulse - Unit is in a 24 hour fast charge of the battery.
- LED Two Blink Red - Battery has failed a capacity test, or the battery is disconnected. See "Clearing Failure Codes" above.
- LED Three Blink Red - Battery charge circuit has failed. See "Clearing Failure Codes" above.
- LED Four Blink Red - Lamps have burned out, or on an EXIT/Combo, 50% or more of the LEDs have failed. See "Clearing Failure Codes" above.
- LED Steady Yellow - 30 second test or 10 second quick test (Fast Charge only).
- LED Blinking Yellow - 90 minute test

MAINTENANCE: None required. Replace the batteries as needed according to ambient conditions. However, we recommend that the equipment be tested regularly in accordance with local codes.

NOTE: Servicing of any parts should be performed by qualified personnel. Only use replacement parts supplied by Cooper Lighting.

CAUTION: This equipment is furnished with a sophisticated low voltage battery dropout circuit to protect the battery from over discharge after its useful output has been used. Allow 24 hours recharge time after installation or power failure for 90 minute testing.

TROUBLE SHOOTING GUIDE

If LED heads or charge indicator LED does not illuminate, check the following:

1. Check AC supply – verify that unit has 24 hour AC supply.
2. Unit is shorted or battery is not connected.
3. Battery discharged. Permit unit to charge for 24 hours and then re-test.
4. If following the above trouble shooting hints does not solve your problem, contact your local Cooper Lighting representative for assistance.

SCHEMATIC

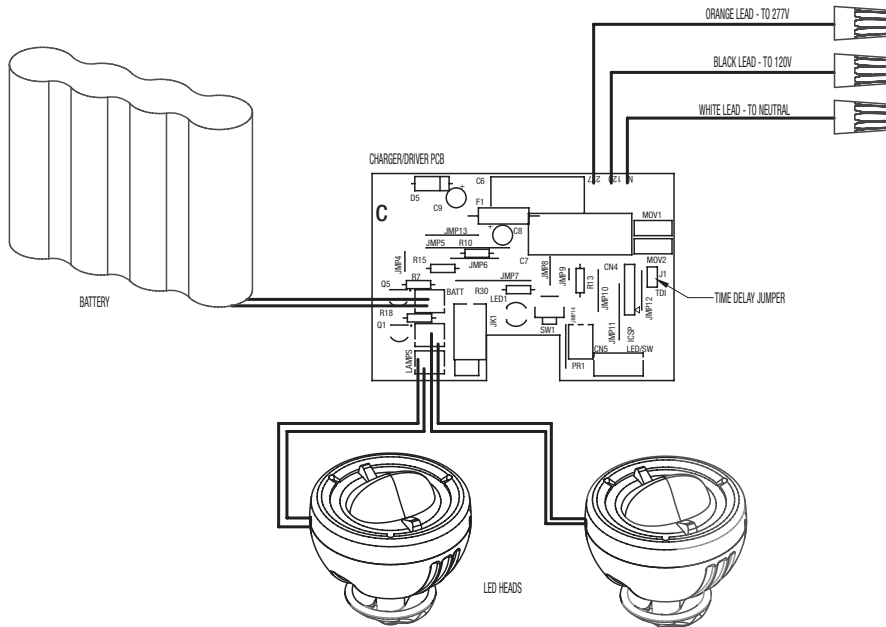

<ul style="list-style-type: none"> ○ OFF - EMERGENCY MODE / POWER OFF ● STEADY BLINK GREEN - FAST CHARGE ● STEADY GREEN - FULL / FLOAT CHARGE ● STEADY YELLOW - QUICK TEST 	<ul style="list-style-type: none"> ● STEADY BLINK YELLOW - 90 MINUTE TEST ●● 2 BLINK RED - BATTERY FAILURE ●●● 3 BLINK RED - CHARGE CIRCUIT FAILURE ●●●● 4 BLINK RED - LAMP/ LED FAILURE
--	--

Cooper Lighting
1121 Highway 74 South
Peachtree City, GA 30269
770.486.4800 Fax: 770.486.4801
7/19/12 049-221