

# HomeRunner Box - the fastest, easiest way to get you connected to HOME!



Eaton's Crouse-Hinds HomeRunner™ Junction Boxes are designed specifically for commercial construction applications to provide a spacious, flexible junction box for terminating home runs and other electrical wiring. Its patented clamping design and flexibility make it the most convenient, labor savings junction box available.

#### Features:

- Designed and approved for use with AC, MC, MCI-A, NM or EMT
- Patented clamping feature eliminates the need for field punching/drilling of KOs and installation of connectors
- Standard surface or flush cover options - eliminates the need for custom covers
- Multiple mounting holes and knockouts for installation flexibility
- Optional stud bracket for direct mounting to steel or wood studs
- Kick stand far side support available with HR080803
- Available in 2 sizes to match customer requirements and preferences
- Third party certified for US and Canada

#### Certifications & Compliances:

- For US & Canada: CSA File #248782
- Certified to UL50 & UL514B and CSA C22.2, No. 18.3-04 & No. 40-M1989

#### Standard Materials:

- Enclosure and cover - pre-galvanized steel
- Hardware - zinc plated steel

#### Dimensions:

- 8" x 8" x 3"
- 12" x 12" x 4"

**Crouse-Hinds**  
by **EAT•N**

# HomeRunner™ Box

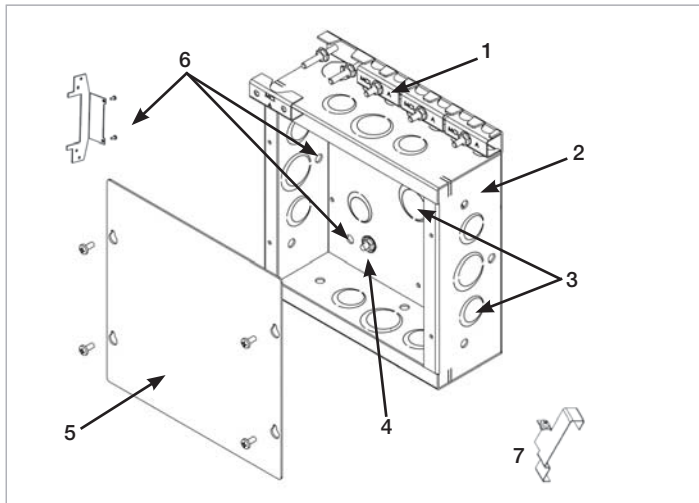

## Features:

- Patented clamping system** - provides maximum flexibility and maximum grip. Third party certified for use with AC, MC, MCI-A or non-metallic sheathed cable.
- Welded steel construction** - provides strong, dependable service and large cubic capacity for ease of wiring.
- Combination eccentric knockouts** - on sides for quick & easy access, combination KO's in the back of the box are ideal for applications where joist spacing is too tight for side entry.
- Terminal cup washer and flanged nut** - quick, easy service ground termination or attachment of grounding bus-bar.
- 2 cover options** - square for surface mounted applications or oversized for flush mount applications.
- Extensive mounting flexibility** - pre-drilled holes in side and back for direct mounting or for mounting bracket (purchased separately).
- Far-side support** - snaps on quickly and easily and is perforated which allows for adjustment in dual thickness, fire-rated walls. Shipped standard with 8" x 8" x 3" models.



HomeRunner Box 8 x 8



HomeRunner Box 12 x 12



Surface Mount Cover



Flush Mount Cover

## HomeRunner Ordering Information

Cat. #	Description	Dimensions	Knockouts	Wire Fill	Built In Clamps	Cubic Vol.	Unit Qty.	Wt. Per 100
HR080803	8" x 8" Box	8"H x 8"W x 3"D	(10) ½" & ¾" eccentric, (7) ¾" & 1" eccentric	(7) 14 AWG (6) 12 AWG (5) 10 AWG	(1) 10/3 to 10/12 (5) 14/2 to 10/3	177	5	400
HR121204	12" x 12" Box	12"H x 12"W x 4"D	(9) ½" (8) ½" - ¾" eccentric (6) ¾" - 1" eccentric (6) 1" - 1 ¼" eccentric	(270) 14 AWG (240) 12 AWG (216) 10 AWG	(1) 10/3 to 10/12 (10) 14/2 to 10/3	544	5	800
HRC0808S	Surface Mount Cover	8"H x 8"W x .06"D	-	-	-	-	5	100
HRC0808F	Flush Mount Cover	9.38"H x 9.38"W x .06"D	-	-	-	-	5	160
HR1212S	Surface Mount Cover	12"H x 12"W x .065"T	-	-	-	-	5	270
HR1212F	Flush Mount Cover	13.38"H x 13.38"W x .065"T	-	-	-	-	5	230
HRSB1	Stud Bracket	-	-	-	-	-	20	35