

Hot Dip Galvanized Products

FD Boxes & Covers

Applications:

Cast device boxes are installed to:

- Accommodate wiring devices
- Act as pull boxes for conductors in a conduit system
- Provide openings to make splices and taps in conductors
- Use indoors and outdoors
- Use in applications where boxes may be subjected to rough use

Features:

- Green ground screw is located on the flange of the box for easy ground wire termination and is standard on boxes
- Suitable for use in wet locations when used with gasket and flat blank covers
- Mounting lugs standard
- Tapered threaded hubs (NPT) with integral bushing
- Available as shallow (FS) or deep (FD) configuration
- Ample wiring room provided in either FS or FD configuration
- Wide selection of surface or flush covers available in three materials (sheet malleable, steel, aluminum)
- Malleable iron construction provides high tensile strength for strong, dependable service
- Covers are individually bagged and supplied with screws

Certifications and Complies:

- cULus
- cCSAus

Standard Material:

- Malleable iron

Standard Finish:

- Hot dip galvanized

FD COVERS – MALLEABLE



FBCM1 HDG

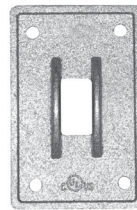

SWCM1 HDG



RCM1 HDG

Cat. #	Description	Unit Qty.	Wt. Lbs. Per 100
FBCM1 HDG	Malleable Iron Flat Blank Cover	25	56
SWCM1 HDG	Malleable Iron Switch Cover	25	63
RCM1 HDG	Malleable Iron Duplex Receptacle Cover	25	55

FD BOXES



FDM1 HDG

Cat. #	Size	Unit Qty.	Wt. Lbs. Per 100
FDM1 HDG	1/2"	2	278
FDM2 HDG	3/4"	2	273
FDM3 HDG	1"	2	284

FDC BOXES



FDCM1 HDG

Cat. #	Size	Unit Qty.	Wt. Lbs. Per 100
FDCM1 HDG	1/2"	2	313
FDCM2 HDG	3/4"	2	294
FDCM3 HDG	1"	2	306

FD Dimensions

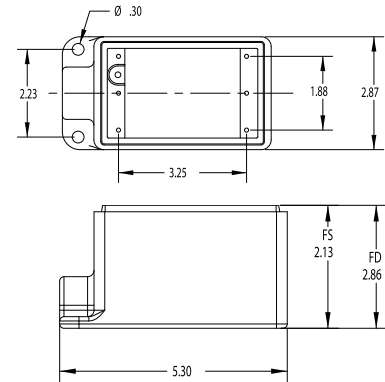

FDC Dimensions

