

Fiberglass Enclosures Advantage Series

The Advantage Series is our most extensive selection of durable industrial non-metallic boxes. Available in a wide range of options, the Advantage Series is available in over 36 various configurations with options such as stainless steel hinges or stainless steel pull latches each with or without clear covers. These enclosures are made of fiberglass-reinforced polyester and have a poured polyurethane seamless gasket that provides a watertight and dusttight environmental seal for exceptional corrosion and chemical resistance. The resilient Advantage Series will provide high impact resistance in the most extreme conditions and provide protection and reliability in the most adverse applications.



Features:

- Memory retaining continuous polyurethane gasket
- No penetrating hardware
- Chemical-resistant fiberglass-reinforced polyester
- Non-corrosive design
- Watertight, dusttight
- Non-conductive, impact-resistant, UV-resistant
- Material cuts, drills, punches and saws with ease and accuracy
- Rounded edges, minimal protrusions or exposed pocket areas for assembly of dust and debris
- Smooth surface, no color variations, swirls or color pockets, no voids

Standard Materials and Finishes:

- Hot compression molded fiberglass-reinforced thermoset polyester
- Poured polyurethane seamless gasket provides watertight, dusttight environmental seal
- 304 stainless steel used on all external hardware
- Panel mounting capability for fixed rear panel
- Bosses utilize threaded brass inserts accepting 10-32 screws

Certifications and Compliances:

- UL/cUL 50, Types 1, 3, 3S, 4X, 12, 13
- UL File No. E-57656
- CSA Std. C22.2 - File 244248 Types 1, 3, 3S, 4X, 12, 13
- NEMA Standard 250 - Types 1, 3, 3S, 4X, 12, 13
- Temperature range: -76°F to +250°F (-60°C to +120°C)
- Flammability rating: UL94-5V
- Non-flame propagating
- IP66

Options:

- | Description | Cat. # |
|--|------------|
| • Mounting feet kit for field installation | FAMTGFTKIT |



Inside H x W x D	Cat. # Two Cover Screws with Hinged Cover	Cat. # Hinged Cover with Padlock Latch	Cat. # Two Cover Screws with Clear Hinged Cover	Cat. # Hinged Cover with Padlock Latch	Cat. # Cover Panel with Mounting Hardware	Cat. # Mounting Plate*
7.41 x 7.79 x 4.31	FAHS060604	FAHP060604	FAHSCC060604	FAHPCC060604	FACP0606SA	FMP0606
9.41 x 7.79 x 4.31	FAHS080604	FAHP080604	FAHSCC080604	FAHPCC080604	FACP0806SA	FMP0806
9.39 x 9.76 x 4.31	FAHS080804	FAHP080804	FAHSCC080804	FAHPCC080804	FACP0808SA	FMP0808
11.42 x 9.79 x 6.31	FAHS100806	FAHP100806	FAHSCC100806	FAHPCC100806	FACP1008SA	FMP1008
13.45 x 11.83 x 6.31	FAHS121006	FAHP121006	FAHSCC121006	FAHPCC121006	FACP1210SA	FMP1210
15.49 x 13.86 x 6.34	FAHS141206	FAHP141206	FAHSCC141206	FAHPCC141206	FACP1412SA	FMP1412
15.49 x 13.86 x 8.34	FAHS141208	FAHP141208	FAHSCC141208	FAHPCC141208	FACP1412SA	FMP1412
17.58 x 15.96 x 8.34	FAHS161408	FAHP161408	FAHSCC161408	FAHPCC161408	FACP1614SA	FMP1614
19.77 x 18.15 x 10.34	FAHS181610	FAHP181610			FACP1816SA	FMP1816
21.79 x 18.16 x 10.34	FAHS201610	FAHP201610			FACP2016SA	FMP2016

* Available in: aluminum (SA), fiberglass (FG), carbon steel (C) and 304 stainless steel (SS). To order, add the suffix to the end of the catalog number.

Fiberglass Enclosures Advantage Series

Dimensional Drawings:

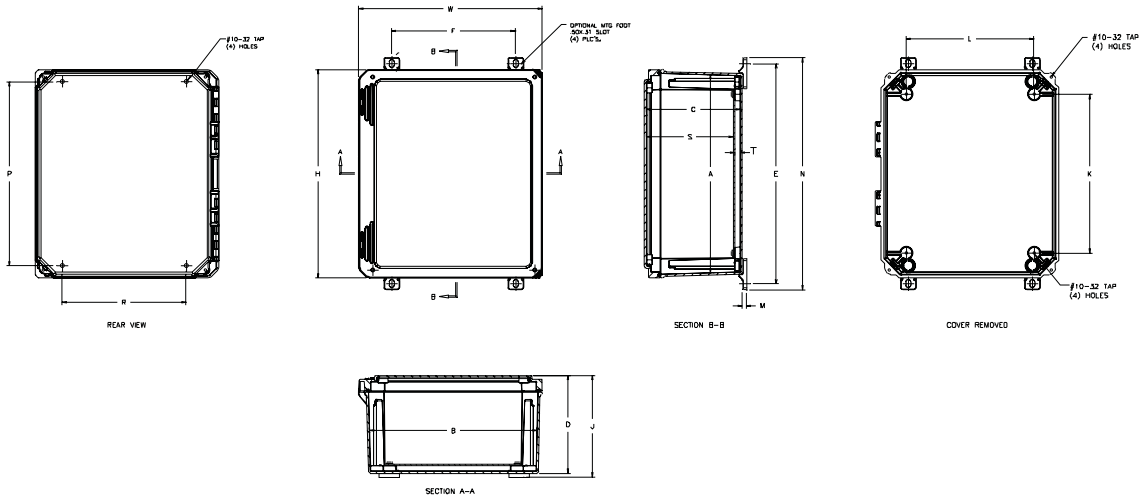

Configuration Dimensions (in Inches (mm)):

Cat. #	Overall H x W x D	Inside A x B x C	Mounting P x R	K	L	S	T	Opt. Mtg. Feet E x F	N	J	M	Weight (Lbs.)
FAHS060604 FAHP060604 FAHSCC060604 FAHPCC060604	7.41 H (188.3) 7.79 W (197.9) 4.31 D (109.5)	6.77 x 6.77 x 4.06 (171.9 x 171.9 x 103.2)	5.93 x 4.00 (150.6 x 101.6)	4.25 (108)	4.25 (108)	3.60 (91.5)	0.38 (9.6)	8.24 x 4.00 (209.2 x 101.6)	9.02 (229.0)	4.56 (115.8)	0.25 (6.35)	2.5
FAHS080604 FAHP080604 FAHSCC080604 FAHPCC080604	9.41 H (239.1) 7.79 W (197.9) 4.31 D (109.5)	8.77 x 6.77 x 4.06 (222.7 x 171.9 x 103.2)	7.91 x 4.00 (200.9 x 101.6)	6.25 (159)	4.25 (108)	3.60 (91.5)	0.38 (9.6)	10.21 x 4.00 (259.3 x 101.6)	10.98 (279.0)	4.56 (115.8)	0.25 (6.35)	3.0
FAHS080804 FAHP080804 FAHSCC080804 FAHPCC080804	9.39 H (238.5) 9.76 W (248.0) 4.31 D (109.5)	8.74 x 8.74 x 4.06 (222.1 x 222.1 x 103.2)	7.91 x 6.00 (200.9 x 152.4)	6.25 (159)	6.25 (159)	3.60 (91.5)	0.38 (9.6)	10.21 x 6.00 (259.3 x 152.4)	10.98 (279.0)	4.56 (115.8)	0.25 (6.35)	3.5
FAHS100806 FAHP100806 FAHSCC100806 FAHPCC100806	11.42 H (290.1) 9.79 W (248.6) 6.31 D (160.3)	10.73 x 8.73 x 6.06 (272.5 x 221.7 x 153.9)	9.89 x 6.00 (251.2 x 152.4)	8.25 (210)	6.25 (159)	5.60 (142.3)	0.38 (9.6)	12.19 x 6.00 (309.6 x 152.4)	12.96 (329.3)	6.56 (166.6)	0.25 (6.35)	4.5
FAHS121006 FAHP121006 FAHSCC121006 FAHPCC121006	13.45 H (341.6) 11.83 W (300.5) 6.31 D (160.3)	12.69 x 10.69 x 6.06 (322.3 x 271.5 x 153.9)	11.88 x 8.00 (301.7 x 203.2)	10.25 (260)	8.25 (210)	5.60 (142.3)	0.38 (9.6)	14.18 x 8.00 (360.2 x 203.2)	14.95 (379.7)	6.56 (166.6)	0.25 (6.35)	6.0
FAHS141206 FAHP141206 FAHSCC141206 FAHPCC141206	15.49 H (393.4) 13.86 W (352.0) 6.34 D (161.0)	14.72 x 12.72 x 6.06 (373.9 x 323.1 x 153.9)	13.91 x 10.00 (353.3 x 254.0)	12.25 (311)	10.25 (260)	5.60 (142.3)	0.38 (9.6)	16.21 x 10.00 (411.7 x 254.0)	16.98 (431.4)	6.59 (167.4)	0.25 (6.35)	8.0
FAHS141208 FAHP141208 FAHSCC141208 FAHPCC141208	15.49 H (393.4) 13.86 W (352.0) 8.34 D (211.8)	14.66 x 12.66 x 8.06 (372.4 x 321.6 x 204.7)	13.88 x 10.00 (352.5 x 254.0)	12.25 (311)	10.25 (260)	7.60 (193.2)	0.38 (9.6)	16.19 x 10.00 (411.2 x 254.0)	16.96 (430.9)	8.59 (218.2)	0.25 (6.35)	9.5
FAHS161408 FAHP161408 FAHSCC161408 FAHPCC161408	17.58 H (446.6) 15.96 W (405.4) 8.34 D (211.8)	16.69 x 14.69 x 8.06 (424.0 x 373.1 x 204.7)	15.96 x 12.00 (405.4 x 304.8)	14.25 (362)	12.25 (311)	7.60 (193.2)	0.38 (9.6)	18.26 x 12.00 (464.0 x 304.8)	19.04 (483.5)	8.59 (218.2)	0.25 (6.35)	11.5
FAHS181610 FAHP181610	19.77 H (502.2) 18.15 W (461.0) 10.34 D (262.6)	18.63 x 16.63 x 10.06 (473.2 x 422.4 x 255.5)	17.94 x 14.00 (455.6 x 355.6)	16.25 (413)	14.25 (362)	9.60 (243.9)	0.38 (9.6)	20.24 x 14.00 (514.3 x 355.6)	21.02 (533.8)	10.59 (268.9)	0.25 (6.35)	16.0
FAHS201610 FAHP201610	21.79 H (553.5) 18.16 W (461.2) 10.34 D (262.6)	20.63 x 16.63 x 10.06 (524.0 x 422.4 x 255.5)	19.96 x 14.00 (506.9 x 355.6)	18.25 (463)	14.25 (362)	9.59 (243.7)	0.38 (9.6)	22.26 x 14.00 (565.6 x 355.6)	23.04 (585.1)	10.59 (268.9)	0.25 (6.35)	17.5