

REV	DATE	DESCRIPTION	ECO	BY	C'H'K.
F	02/25/2013 00:00:00 AM	ADD YCA33R2N90 TO SALES DRAWING SD029515.	30638	MRA	MB

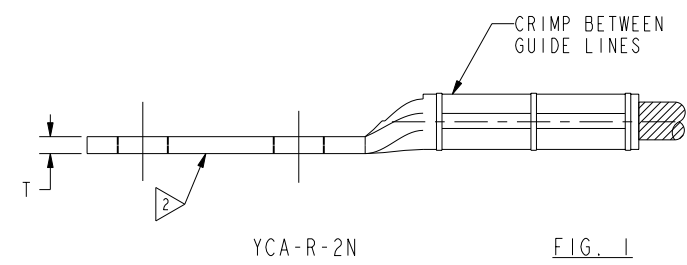

TYPICAL LETTERING AS SHOWN

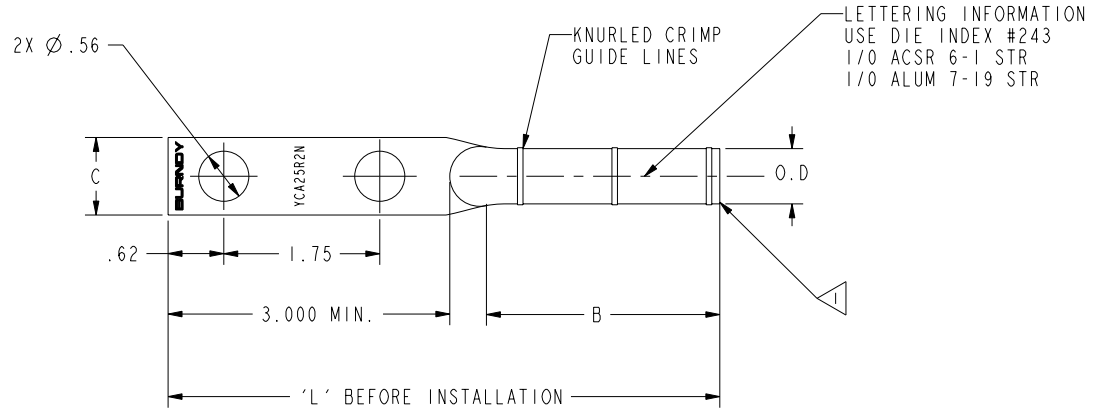
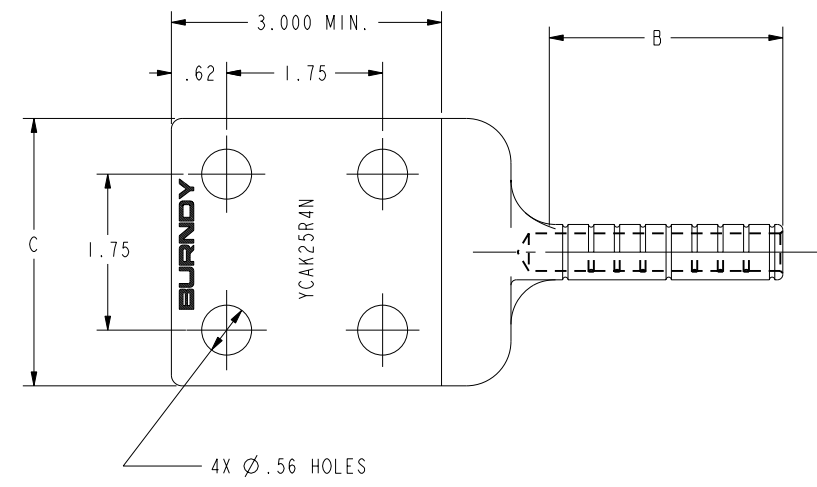

YCAK-R-4N FIG. 2

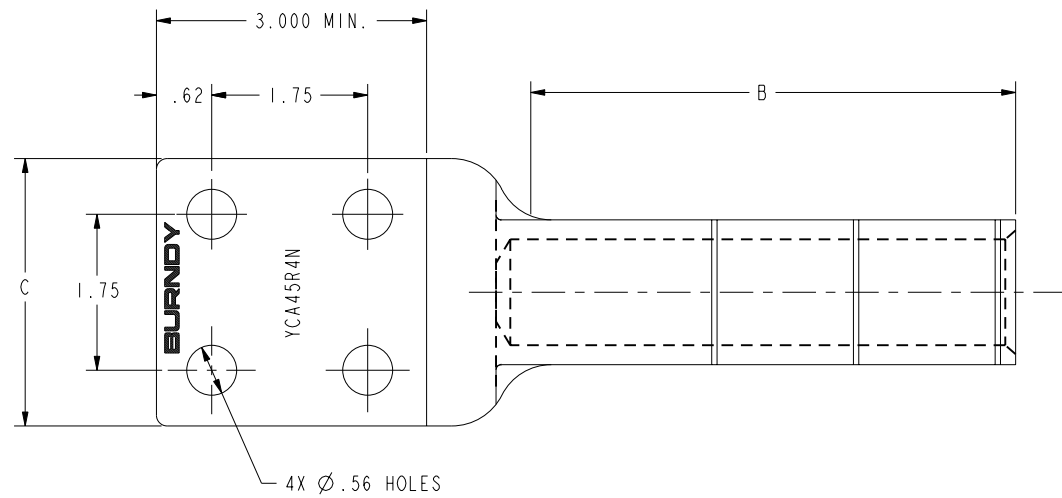

YCA-R-4N FIG. 3

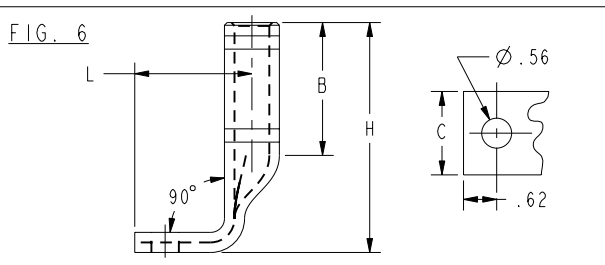
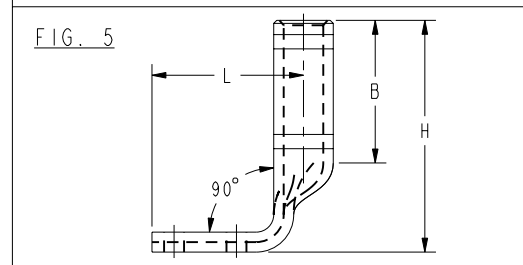
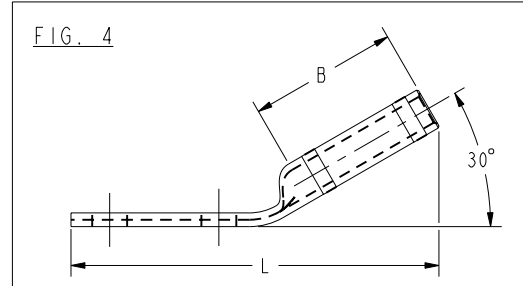

NOTES:

- 1 BARRELS PARTIALLY FILLED WITH PENETROX™ & SEALED.
- 2 TONGUE COATED WITH AN OXIDE RETARDANT.
- 3 CAST CONNECTOR.
- 4 FLAT SIDED BARREL.
- 5 CRIMPS WILL OVERLAP WHEN USING Y48B, Y436RB HYPRESSES™.
- 6 HYTOOLS™ MD5-3, MD5-4, MD5-7, MD5-9, MD5-12.
- 7 CRIMPS OVERLAP.
- 8 ALTERNATE CAT. NO. YCA50R2N, YCA50R4N.
- 9 "TN" AT THE END OF CAT. NO. INDICATES THE CONNECTOR WILL BE SUPPLIED TIN PLATED.
- 10 FOR UNDRILLED VERSIONS ADD SUFFIX LETTER "U" TO END OF CATALOG NUMBER.

MATERIAL: ALUMINUM
FIG. 1 & 3 - TUBE
FIG. 2 - CAST

SUPERSEDES: SD36296-14

REFERENCE:
SD45884

TO ORDER BURNDY® PRODUCTS CALL		HYLUG™(ACSR & AL.) NEMA	
UNITED STATES 1-800-346-4175 (LONDONDERRY, NH)		ITEM NO: ---	CAT. NO: SEE TABLE
CANADA: 1-800-361-6975 (QUEBEC) 1-800-387-6487 (ALL OTHER PROVINCES)		DRAWN BY: B.L.C. 7-14-61	CHECKER: EPG 7-26-61
FOR PRODUCT INFO: http://www.burndy.com		DSN APPVL: ---	MFG APPVL: ---
		QA APPVL: ---	MKT APPVL: ---
		PROJ #:	SIZE: D
		DOCUMENT TYPE: Sales	SCALE: 1:1
		REL LEVEL: Released	DRAWING NO: SD029515
			REV: F
			SHEET 1 OF 4

REV: PE0200

DRAWING NO.
SD029515

7

6

5

4

3

2

1

CATALOG NUMBER	CONDUCTOR RANGE				FIG. NO.	B	C	L (APPROX)	O.D.	T	TOOL INDEX NO.	INSTALLATION DATA										SEE NOTE NO.							
	ACSR		ALUM									HYTOOL™ WITH NO. OF CRIMPS					HYPRESS™ & DIE SET WITH NO. OF CRIMPS												
	AWG Kcmil	STR	AWG Kcmil	STR								MD4 (DIE SET)	MD5	MD6 (DIE SET)	Y34A	Y35/Y750	Y48B	Y486RB	Y60										
YCA4R2N	#4 (.250) (.257)	6-1 7-1	#4 (.232)	7	1	1.61	1.25	5.66	.42	.25	237		W3-T	5	MD5-1	5	W237	8	A4RYF	2	U4RYFT	2							3
YCA2R2N	#2 (.316) (.325)	6-1 7-1	#2 (.292)	7	1	1.61	1.25	5.90	.52	.25	239		W3-T W8-T	5	MD5-1	5	W239	8	A2RYF	2	U2RYFT	2							3
YCA25R2N	1/0 (.398)	6-1	1/0 (.373)	7, 19	1	2.39	.87	6.19	.62	.19	B-G 243	MD3	W4-T W5-T W8-T	8		8	B-G GROOVE W-243	8	A25RYF	2	U25RYFT	2	C243	1					
YCA26R2N	2/0 (.447)	6-1	2/0 (.419)	7, 19	1	2.43	.97	6.30	.70	.22	245		W5-T	8	MD5-7	8	W245	4	A26RYF	2	U26RYFT	2	C245	1			L26RYFT1		
YCA27R2N	3/0 (.502) 110.8 (.481)	6-1 12-7	3/0 (.470)	7, 19	1	2.74	1.08	6.73	.78	.25	247						W247	6	A27RYF	3	U27RYFT	3	C247	2				5	
YCA28R2N	4/0 (.563)	6-1 6-7	4/0 (.528)	7, 19	1	2.80	1.21	6.83	.88	.28	249						W249	6	A28RYF	3	U28RYFT	3	C249	2				5	
YCA30R2N	266.8 (.609) (.633) (.642)	18-1 6-7 26-7	266.8 (.593)	7, 19	1	2.57	1.42	6.71	1.00	.32	251								A30RYF	4	U30RYFT	4	C251	2					
YCA321R2N	336.4 (.684)	18-1	336.4 (.666) 350 (.678) (.681)	19 19 37, 61	1	2.68	1.54	6.95	1.12	.41	321								A321RYF A301AYD	4	U705 U321RYFT U301AYDT	4	C490 C321	2				4	
YCA33R2N	336.4 (.721) (.741)	26-7 30-7	397.5 (.724)	19	1	3.00	1.60	7.29	1.14	.35	316									U33RYFT U705	4	C316	2	F33RYF	2			5	
YCA35R2N	397.5 (.783) (.743) (.806)	26-7 18-1 30-7	477 (.793) (.795) 500 (.813)	19 37 37, 61	1	3.02	1.84	7.44	1.25	.35	317									U35RYFT	4	C317	2					5	
YCA361R2N	477 (.814)	18-1	500 (.813)	37, 61	1	3.24	1.82	7.69	1.30	.44	327									U361RYFT	5	C327	2					5	
YCA37R2N	477 (.846) (.858) (.883) 556.5 (.879)	24-7 26-7 30-7 18-1	556.5 (.856) (.858)	19 37	1	3.65	1.94 MAX	8.15	1.36	.38	261										U261	5	C261	2	F37RYF	2			5
YCA521R2N	1272 (1.345)	45-7			1	6.41	3.09	11.50	2.25	.8	648												F49RYF-1	4	L49RYF-1	4		5	
YCA521R4N					3																								
YCAK549R4N	1590 (1.508)	45-7			2	8.44	3.00	13.69		1.00	729																		
YCAK463A4N			1600 (1.459)	127	2	6.50	3.00	11.62	2.26	.75	478												C478	2	F478	2	L478		

REV	DATE	DESCRIPTION	ECO	BY	C'H'K.
F	02/25/2013 00:00:00 AM	ADD YCA33R2N90 TO SALES DRAWING SD029515.	30638	MRA	MB

REV: PE0200

TO ORDER BURNDY® PRODUCTS CALL		HYLUG™(ACSR & AL.) NEMA	
UNITED STATES		ITEM NO: --	
1-800-346-4175 (LONDONDERRY, NH)		CAT. NO: SEE TABLE	
CANADA:		DRAWN BY: B.L.C. 7-14-61	
1-800-361-6975 (QUEBEC)		CHECKER: EPG 7-26-61	
1-800-387-6487 (ALL OTHER PROVINCES)		DSN APPVL: --	
FOR PRODUCT INFO: http://www.burndy.com		MFG APPVL: --	
		QA APPVL: --	
		MKT APPVL: --	
		PROD FAM: --	
		DRAWING NO	
		SD029515	
		REV	
		F	
		SCALE: 1:1	
		SHEET 2 OF 4	

8

7

6

5

4

3

2

1

A

B

C

D

DRAWING NO.
SD029515

CATALOG NUMBER	CONDUCTOR RANGE				FIG. NO.	B	C	L (APPROX)	O.D.	T	TOOL INDEX NO.	INSTALLATION DATA					SEE NOTE NO.							
	ACSR		ALUM									HYPRESS™ & DIE SET WITH NO. OF CRIMPS												
	AWG Kcmil	STR	AWG Kcmil	STR								Y45L	Y35/Y750	Y48B	Y486RB	Y60								
YCA39R2N	556.5 (.914)	24-7			1	3.59	2.08	8.31	1.50	.53	608	S-608	2	U39RYFT	6	C608	2	F39RYF	2		4			
YCAK39R4N	(.927)	26-7			2	3.56	3.00	8.06		.50														
YCA361A2N			636 (.918)	37	1	3.59	2.08	8.22	1.50	.53	469	S-469	4			C469	2							
YCAK361A4N					2	3.56	3.00	8.55		.50														
YCA43R2N	605 (.994)	30-19	795 (1.026)	37	1	5.30	2.48	10.28		.78						C292		F412RYF-1						
YCAK43R4N	636 (.977)	24-7	(1.028)	61	2	5.25	3.00	9.69		.62		S-292										4		
	(.990)	26-7	700 (.964)	61					1.84			S-578	6											
	(1.019)	30-19	750 (.998)	61								S-319				C319		F43RYF						
	666.6 (1.000)	24-7																						
YCA391A2N			795 (1.026)	37	1	5.24	2.32	10.06	1.67	.58	342	S-342	6			C342	3							
YCAK391A4N			750 (.998)	61	2	5.25	3.00	9.88		.56														
YCA453R2N	795 (1.04)	36-1			1	5.31	2.52	10.28		.70		S-292				C292	3	F412RYF-1	3				4	
YCAK453R4N	715.5 (1.051)	26-7			2	5.25	3.00	9.64	1.84	.62		S-578	6											
	795 (1.063)	45-7																						
YCA45R2N	795 (1.093)	54-7	900 (1.094)	61, 91	1	5.31	2.55	10.28		.65		S-352				C352	3	F45RYF	3				4	
YCAK45R4N	(1.108)	26-7	954 (1.126)	37, 61	2	5.25	3.00	9.64	1.84	.62	352	S579	6			C579	3						3	
YCAK45R4N30			1000 (1.152)	61	4	5.25	3.00	10.00		.62														
	1033.5 (1.186)	36-1								--														
	1033.5 (1.219)	45-7																						
YCA48R2N	954 (1.196)	54-7			1	4.75	2.89	10.00	2.12	.86	575					C575	3	F48RYF	3				4	
YCA48R4N	954 (1.165)	45-7			3	4.75	3.00	10.00		.77														
	900 (1.162)	54-7																						
YCA441A2N			1033.5 (1.170)	37	1	4.73	2.85	10.00		.86														4
			(1.172)	61					2.12		575					C575	3	F48RYF	3					4
YCA441A4N			1113 (1.216)	61	3	4.75	3.00	10.00		.77														4
YCA49R2N	1033.5 (1.246)	54-7			1	4.90	2.92	10.16		.80														4
YCAK49R4N	1113 (1.259)	45-7			2	4.88	3.00	9.50	2.12	.75	422							F49RYF	3					
YCA49R4N					3	4.90	3.16	10.16		.69														
YCA451A2N			1272 (1.300)	61	1	4.92	3.00	10.19	2.12	.69	422							F49RYF	3					4
YCA451A4N	1113 (1.293)	54-19			3	4.92	3.00	10.19		.69														
YCA51R4N	1192.5 (1.333)	54-13			3	5.31	3.21	10.79	2.35	.91	684							F51RYR	3					
YCAK50R4N	1113 (1.293)	54-19	1272 (1.300)	61	2	4.88	3.00	9.50	2.12	.75	422							F49RYF	3					4
YCA391A2N30			795 (1.026)	37	4	5.24	2.32	10.00	1.67	.58	342	S-342	6			C342	3							

REV	DATE	DESCRIPTION	ECO	BY	C'H'K.
F	02/25/2013 00:00:00 AM	ADD YCA33R2N90 TO SALES DRAWING SD029515.	30638	MRA	MB

REV: PE0200

TO ORDER BURNDY® PRODUCTS CALL
 UNITED STATES
 1-800-346-4175 (LONDONDERRY, NH)
 CANADA:
 1-800-361-6975 (QUEBEC)
 1-800-387-6487 (ALL OTHER PROVINCES)
 FOR PRODUCT INFO: <http://www.burndy.com>

HYLUG™(ACSR & AL.) NEMA	
ITEM NO:	--
CAT. NO:	SEE TABLE
DRAWN BY:	B.L.C. 7-14-61
CHECKER:	EPG 7-26-61
DSN APPVL:	--
MFG APPVL:	--
QA APPVL:	--
MKT APPVL:	--
PROD FAM:	--
PROJECT #:	--
DOCUMENT TYPE:	Sales
REL LEVEL:	Released



DRAWING NO	REV	SCALE
SD029515	F	1:1
SHEET 3 OF 4		

DRAWING NO.
SD029515

7

6

5

4

3

2

1

REV	DATE	DESCRIPTION	ECO	BY	C'H'K.
F	02/25/2013 00:00:00 AM	ADD YCA33R2N90 TO SALES DRAWING SD029515.	30638	MRA	MB

CATALOG NUMBER	CONDUCTOR RANGE				FIG. NO.	B	C	H	L (APPROX)	O.D.	T	TOOL INDEX NO.	INSTALLATION DATA												SEE NOTE NO.							
	ACSR		ALUM										HYTOOL™ WITH NO. OF CRIMPS						HYPRESS™ & DIE SET WITH NO. OF CRIMPS													
	AWG Kcmil	STR	AWG Kcmil	STR									MD4 (DIE SET)	MD5	MD6 (DIE SET)	Y34A	Y35/Y750	Y45L	Y48B	Y486RB	Y60											
YCAK391A4N90			795 (1.026) 750 (.998)	37 61	5	5.25	3.00	6.50	4.25	1.67	.56	342							S342	6	C342	3										
YCAK521R4N	1272 (1.345)	45.7			2	6.34	3.00		10.59	2.255	.75	648										F49RYF-I	4	L49RYFI	4	5						
YCAK451A4N90			1272 AAC (1.300) 1351.5 AAC (1.340)	61 61	5	4.88	3.00	6.15	4.69	2.13	.75	422										F49RYF	3	4	5							
YCA25R2N30	1/0 (.398)	6-1	1/0 (.373)	7,19	4	2.39	.87		5.81	.62	.19	BG 243	MD3	8	W4-T W5-T W8-T	8	6	8	W-BG W243	8	4	A243	2	U243	2		C243	1		L243	1	
YCA26R2N30	2/0 (.447)	6-1	2/0 (.419)	7,19	4	2.43	.97		5.91	.70	.22	245			W5-T	8	MD5-7	8	W245	4	A245	2	U245	2		C245	1		L245	1		
YCA28R2N30	4/0 (.563)	6-1 6-7	4/0 (.528)	7,19	4	2.80	1.21		6.38	.88	.28	249							W249	6	A249	3	U249	3		C249			L249	5		
YCA321R2N30	336.4 (.684)	18-1	336.4 (.666) 350 (.678) (.681)	19 19 37,61	4	2.68	1.54		6.45	1.12	.41	490 705 321									A490 A321	4	U490 U705 U321	4		C490 C321		F490		L490	4 5	
YCA33R2N30	336.4 (.721) (.741)	26-7 30-7	397.5 (.724)	19	4	3.00	1.60		6.69	1.14	.35	316 705										U316 U705	4		C316		F316		L316	5		
YCA33R2N90	336.4 (.721) (.741)	26-7 30-7	397.5 (.724)	19	5	3.00	1.60	5.32	4.04	1.14	.35	316 705										U316 U705	4		C316			L317				
YCA35R2N30	397.5 (.783) (.806) (.743)	26-7 30-7 18-1	477 (.783) (.795) 500 (.813)	19 37 37,61	4	3.02	1.84		6.84	1.25	.35	317										U317	4		C317		F317		L317	5		
YCA39R2N30	556.5 (.914) (.927)	24-7 26-7			4	3.59	2.08		7.59	1.50	.53	608										U608	6	S608	2	C608	2	F608	2	L608	2	4
YCA453R2N30	795 (1.04) (1.063) 715.5(1.051)	36-1 45-7 26-7			4	5.31	2.53		9.25	1.84	.70	292												S292	6	C292	3	F292	3	L292	3	4
YCA321R2N90	336.4 (.684)	18-1	336.4 (.666) 350 (.678) (.681)	19 19 37,61	6	2.68	1.54	4.69	2.39	1.12	.41	490 705 321									A490 A321	4	U490 U705 U321	4		C490 C321		F490		L490	4 5	
YCA35R2N90TN	397.5 (.783) (.806) (.743)	26-7 30-7 18-1	477 (.783) (.795) 500 (.813)	19 37 37,61	5	3.02	1.84	5.04	4.14 MAX.	1.25	.35	317										U317	4		C317		F317		L317	5		
YCA43R2N90	605 (.994) 636 (.977) (.990) (1.019) 666.6 (1.000)	30-19 24-7 26-7 30-19 24-7	795 (1.026) (1.028) 700 (.964) 750 (.998)	37 61 61 61	5	5.30	2.48	8.73	4.40	1.84	.78	292 OR 319											S-292 S-578 S-319	6	C292	3	F412RYF-I F43RYF	3		4		

D

D

C

C

B

B

A

A

REV: PE0200

8

7

6

5

4

3

2

1

TO ORDER BURNDY® PRODUCTS CALL UNITED STATES 1-800-346-4175 (LONDONDERRY, NH) CANADA: 1-800-361-6975 (QUEBEC) 1-800-387-6487 (ALL OTHER PROVINCES) FOR PRODUCT INFO: http://www.burndy.com		HYLUG™(ACSR & AL.) NEMA ITEM NO: -- CAT. NO: SEE TABLE DRAWN BY: J.R.H 12-8-69 CHECKER: J.P.S 12-10-69 DSN APPVL: M.G 12-10-69 MFG APPVL: -- QA APPVL: -- MKT APPVL: -- PROD FAM: -- PROJECT #: -- DOCUMENT TYPE: Sales REL LEVEL: Released	SCALE: 1:1 DRAWING NO: SD029515 REV: F SHEET 4 OF 4
--	--	---	--

