

REV	DATE	DESCRIPTION	ECO	BY	C'H'K.
A	12/11/2008 12:00:00 AM	REDRAW AND CATALOG NUMBER UPDATION	16630	MA	BSK

CATALOG NO.	CONDUCTOR		BOLT SIZE	FIG. NO.	DIMENSIONS								INSTALLATION TOOLING (# CRIMPS)												
	CODE (AWG)	NAVY			B ±.08	C ±.04	H REF.	K DIA. ±.02	L ±.12	N ±.04	O.D. ±.01	T REF.	Z MIN.	DIE INDEX	COLOR CODE	MECHANICAL		HYDRAULIC						DIELESS (# CRIMPS)	WIRE STRIP LENGTH
																MD7-34R	BCT500 Y500CT	Y34A	Y750	Y46	Y45	Y48B	Y60B		
D YAZ32TC38	400 kcmil [-----]	400	2.12 [54]	1.40 [36]	--		3.61 [92]		.95 [24]	.19 [5]		19 OR 470	BLUE	W32RT (4)	W32RT (4)	A32R A30AR (4)	U32RT U30ART (4)	U32RT U30ART (4)	U32RT U30ART (4)	C32R C30AR (1)	L32RT L30ART (1)	HYDRAULIC Y644, Y644M BAT644M Y644MBH, Y1000 Y1000BH (1)	2-3/16		
YAZ32TC3845					2.69 [68]	.40 [10]	3.24 [82]	.41 [10]			.42 [11]														
YAZ32TC3890					3.12 [79]		1.44 [37]																		
YAZ32TC12					--		3.86 [98]																		
YAZ32TC1245					2.69 [68]	.52 [13]	3.94 [100]	.53 [13]			.55 [14]														
YAZ32TC1290	400 kcmil [-----]	400	2.12 [54]	1.40 [36]	3.12 [79]		1.70 [43]		.95 [24]	.19 [5]		19 OR 470	BLUE	W32RT (4)	W32RT (4)	A32R A30AR (4)	U32RT U30ART (4)	U32RT U30ART (4)	U32RT U30ART (4)	C32R C30AR (1)	L32RT L30ART (1)			2-3/16	

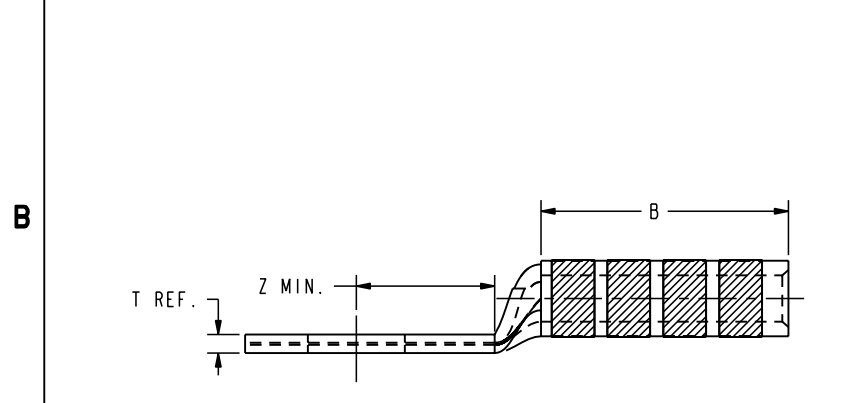
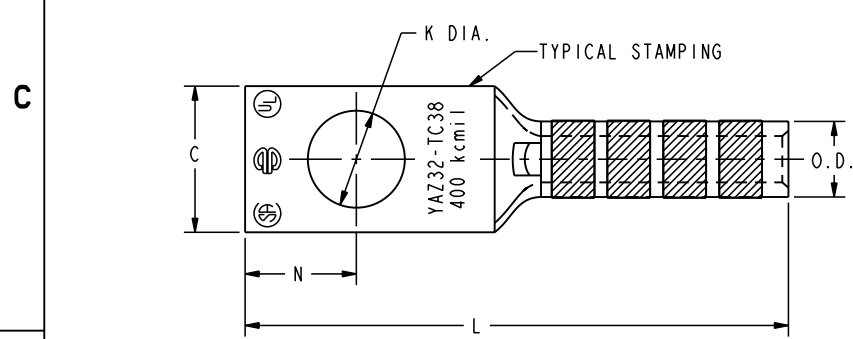

FIG. 1

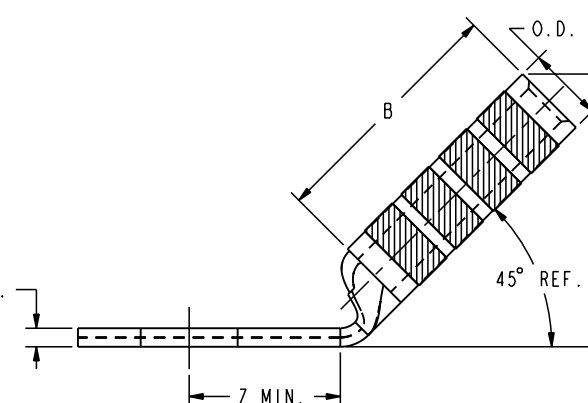
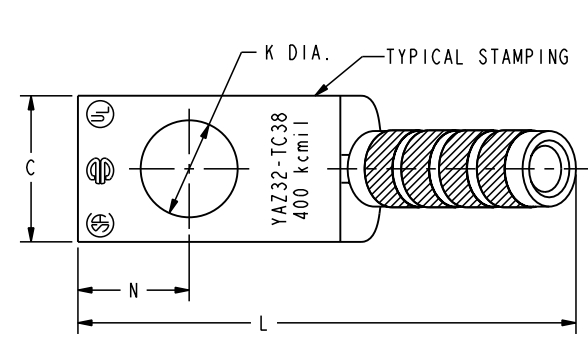

FIG. 2

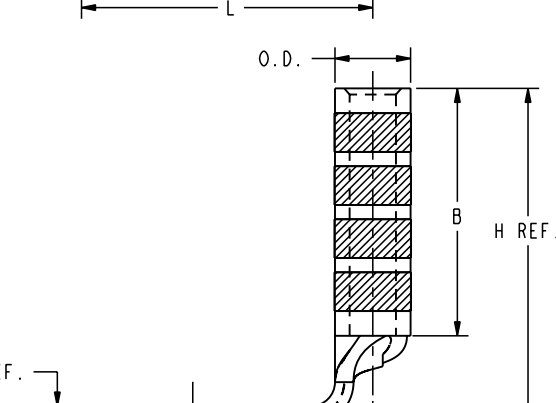
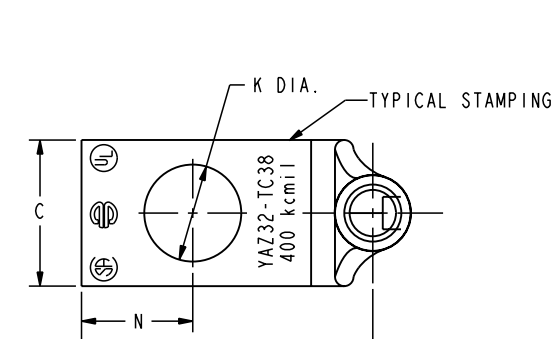

FIG. 3

NOTES:

- MATERIAL: COPPER TUBING.
- FINISH: TIN PLATED
- CATALOG # PT6515 ADAPTOR IS REQUIRED TO USE "U" DIES IN Y45 SERIES TOOLS.
- CATALOG # PUADP-1 ADAPTOR IS REQUIRED TO USE "U" DIES IN Y46 SERIES TOOLS.
- NAVY CABLE SIZE MAY BE OMITTED ON SOME SIZES BECAUSE OF SPACE LIMITATIONS.
- DIMENSIONS, METRIC WIRE, & METRIC BOLT SIZES IN BRACKETS [] ARE IN MILLIMETERS. DIMENSIONS ARE ROUNDED OFF TO THE NEAREST MILLIMETER, UNLESS OTHERWISE NOTED, AND ARE FOR REFERENCE ONLY.
- FOR USE BY CUSTOMERS THAT HAVE THIS HYPRESS™. NO NEW Y34A HYPRESS™ TOOLS ARE BEING PROCESSED.

TO ORDER BURNDY® PRODUCTS CALL		HYLUG™ (ONE HOLE CODE)	
UNITED STATES 1-800-346-4175 (LONDONDERRY, NH)		ITEM NO: NA	CAT. NO: YAZ32-TC- (TABLE)
CANADA: 1-800-361-6975 (QUEBEC) 1-800-387-6487 (ALL OTHER PROVINCES)		DRAWN BY: D. BOISVERT 02/03/2000	CHECKER: K. MCCARTHY 04/05/2000
FOR PRODUCT INFO: http://www.burndy.com		DSN APPVL: J. MICHAUD 05/04/2000	MFG APPVL: N/A
		QA APPVL: S. BROWN	MKT APPVL: N/A
		SCALE: NTS	
		PROJ #:	SIZE
		PROJECT #:	SE212356
		DOCUMENT TYPE: Sales	D
		REL LEVEL: Released	SHEET 24 OF 40

REV: PE0200