

DRAWING NO.
SE211915

7

6

5

4

3

2

1

REV	DATE	DESCRIPTION	ECO	BY	C'H'K.
A	4/11/2008 12:00:00 AM	REDRAW INTO PRO-E & CATALOG NUMBER UPDATION	16757	DG	BSK

CATALOG NO.	CONDUCTOR		BOLT SIZE	FIG. NO.	DIMENSIONS									INSTALLATION TOOLING (# CRIMPS)													
	CODE (AWG)	NAVY			B	C	E	H REF.	K DIA.	L	N	O.D.	T REF.	Y MIN.	DIE INDEX	COLOR CODE	MECHANICAL RATCHET		HYDRAULIC				DIELESS (# CRIMPS)	WIRE STRIP LENGTH			
																	MD7-34R	Y34A	Y750	Y46	Y45	Y48B			Y60B		
YAZ322TC38	400 Kcmil [-----]	400	3/8 [M10]	1	2.12 [54]	1.40 [36]	1.00 [25]	----	.40 [10]	4.62 [117]	.41 [10]	.95 [24]	.19 [5]	1.43 [36]	19 OR 470	BLUE	W32RT (4)	Y34A (4)	Y750 Y39, BAT750 (4)	Y46 (4)	Y45 (3)	Y48B (1)	Y60B (1)	HYDRAULIC: Y644, Y644M, Y644MBH, Y1000 Y1000BH (1)	2-3/16		
2				2.69 [68]				3.12 [79]																		4.25 [108]	2.46 [62]
3																											

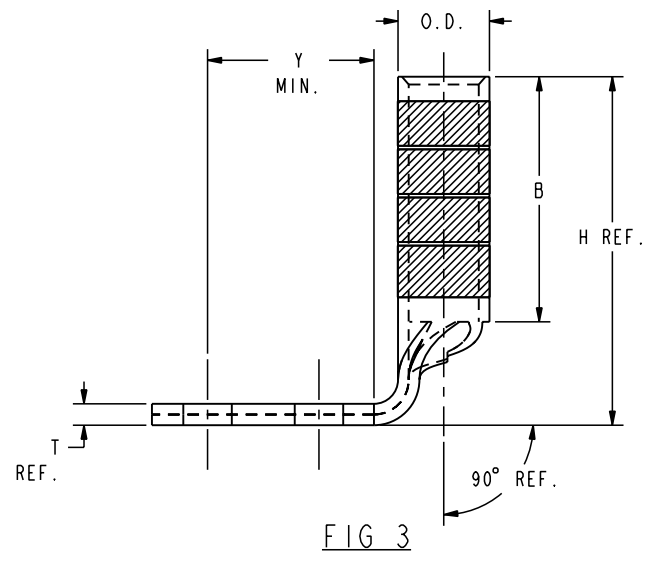
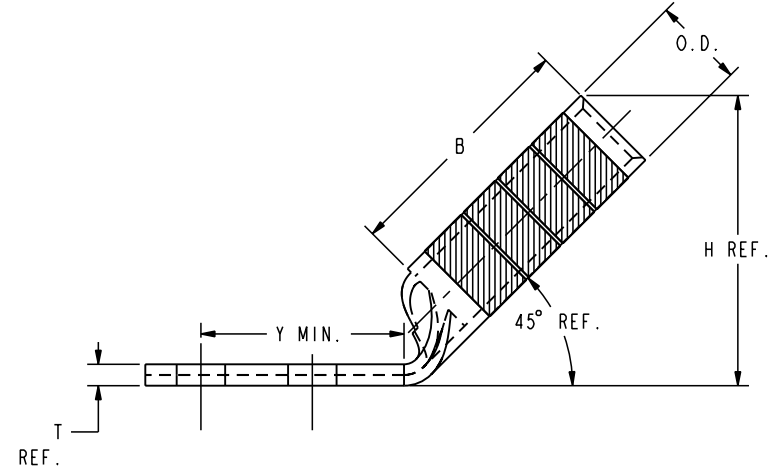
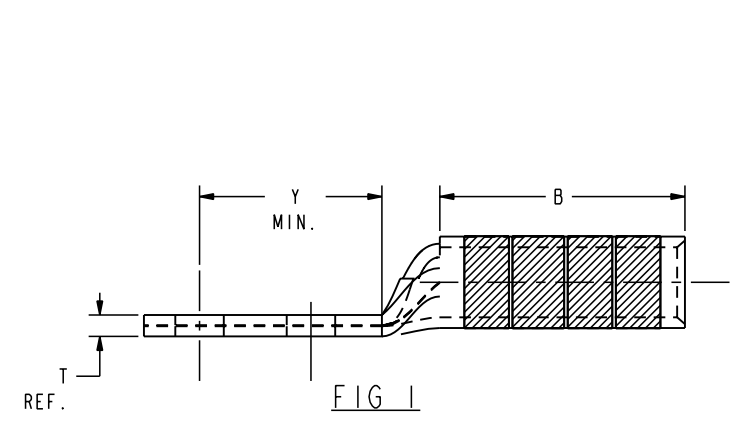
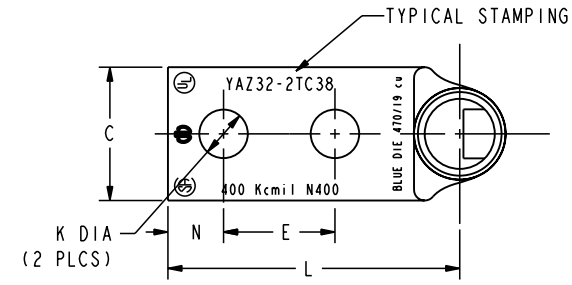
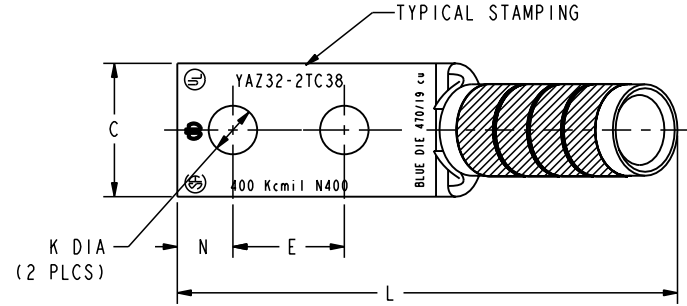
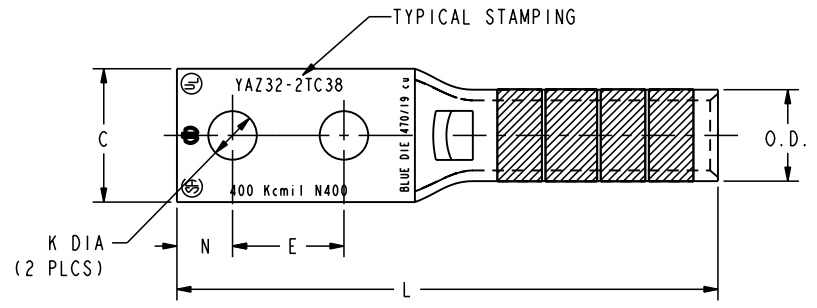

- NOTES:
- MATERIAL: COPPER TUBING.
 - FINISH: TIN PLATED
 - CATALOG # PT6515 ADAPTOR IS REQUIRED TO USE "U" DIES IN Y45 SERIES TOOLS.
 - CATALOG # PUADP-1 ADAPTOR IS REQUIRED TO USE "U" DIES IN Y46 SERIES TOOLS.
 - NAVY CABLE SIZE MAY BE OMITTED ON SOME SIZES BECAUSE OF SPACE LIMITATIONS.
 - DIMENSIONS, METRIC WIRE, & METRIC BOLT SIZES IN BRACKETS [] ARE IN MILLIMETERS. DIMENSIONS ARE ROUNDED OFF TO THE NEAREST MILLIMETER, UNLESS OTHERWISE NOTED, AND ARE FOR REFERENCE ONLY.
 - FOR USE BY CUSTOMERS THAT HAVE THIS HYPRESS.™ NO NEW Y34A HYPRESS™ ARE BEING PROCESSED.

TO ORDER BURNDY® PRODUCTS CALL		HYLUG™	
UNITED STATES 1-800-346-4175 (LONDONDERRY, NH)		ITEM NO: N/A	CAT. NO: YAZ32-2TC- (SEE TABLE)
CANADA: 1-800-361-6975 (QUEBEC) 1-800-387-6487 (ALL OTHER PROVINCES)		DRAWN BY: D. BOISVERT 11/12/98	CHECKER: K. HENRY 12/03/98
FOR PRODUCT INFO: http://www.burndy.com		DSN APPVL: B. MACDONALD 12/02/98	MFG APPVL: N/A
		QA APPVL: S. GARY 11/30/98	MKT APPVL: B. HARDGROVE 11/25/98
		PROJ #: --	SIZE: D
		DOCUMENT TYPE: Sales	SCALE: 4:1
		REL LEVEL: Released	DRAWING NO: SE211915
			REV: A
			SHEET 32 OF 36

8

7

6

5

4

3

2

1