

REV	DATE	DESCRIPTION	ECO	BY	C'H'K.
A	12/11/2008 12:00:00 AM	REDRAW AND CATALOG NUMBER UPDATES	16630	MA	BSK

CATALOG NO.	CONDUCTOR		BOLT SIZE	FIG. NO.	DIMENSIONS								INSTALLATION TOOLING (# CRIMPS)																
	CODE (AWG)	NAVY			B ±.08	C ±.04	H REF.	K DIA. ±.02	L ±.12	N ±.04	O.D. ±.01	T REF.	Z MIN.	DIE INDEX	COLOR CODE	MECHANICAL		HYDRAULIC					DIELESS (# CRIMPS)	WIRE STRIP LENGTH					
																MD7-34R	BCT500 Y500CT	Y34A	Y750 Y35, BAT35 Y39, BAT750	Y46	Y45	Y48B			Y60B				
D YAZ30TC38	300 kcmil [150mm <sup>2</sup> STR]	300	3/8 [M10]	1	2.00	1.20	--		3.41			.81	.16		17	WHITE	W30RT (4)	W30RT (4)	A28R A30R (4)	U30RT U28ART (4)	U30RT U28ART (4)	U30RT U28ART (4)	C30R (1) C28AR (1)	L30RT (1)	HYDRAULIC Y644, Y644M BAT644M Y644MBH, Y1000 Y1000BH (1)	2-1/16			
YAZ30TC3845					2	2.44	.40	3.04	.41																				
YAZ30TC3890					3	2.86		1.36																					
YAZ30TC12					1	--		3.66																					
YAZ30TC1245					2	2.44	.52	3.29	.53																				
YAZ30TC1290					3	2.86		1.61																					

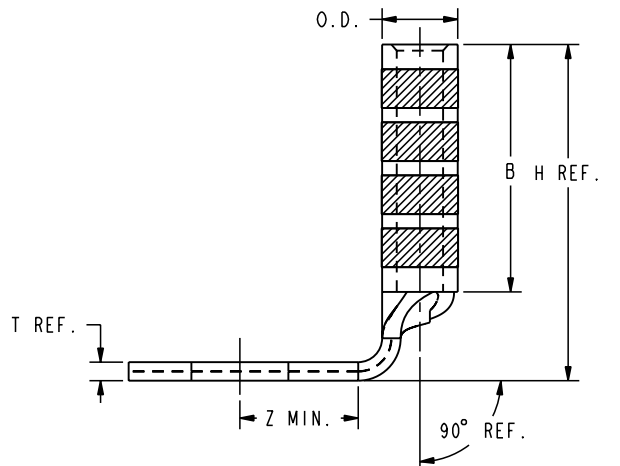
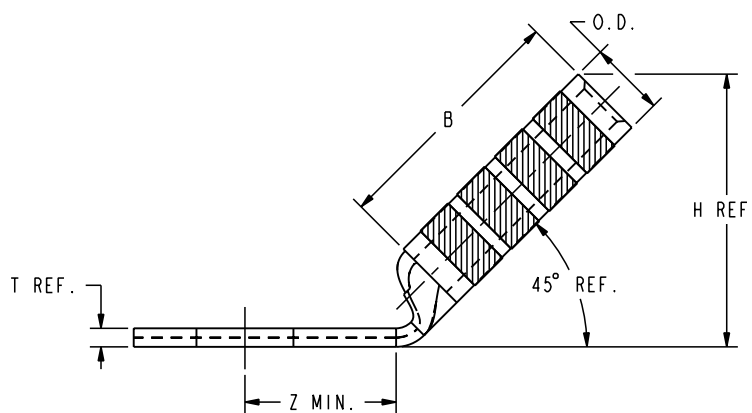
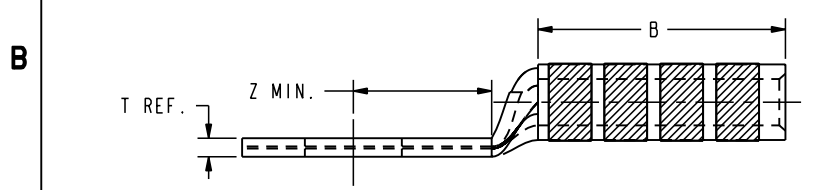
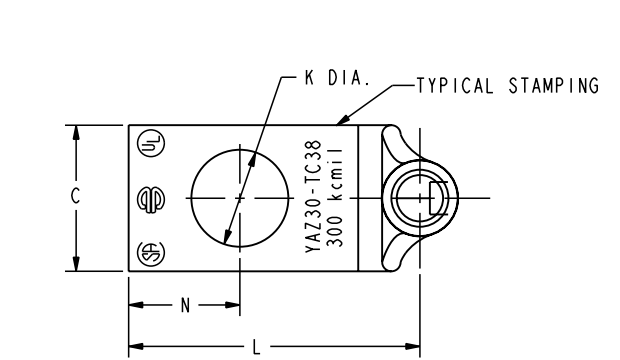
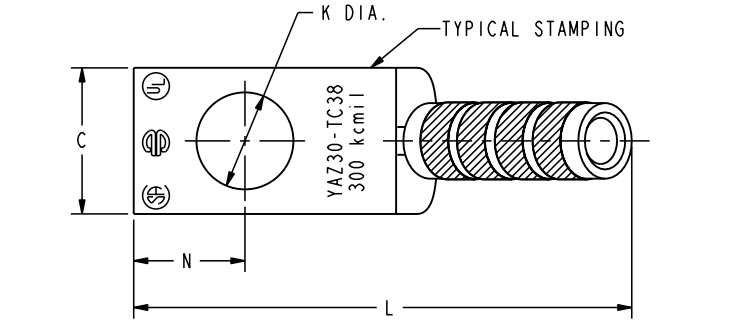
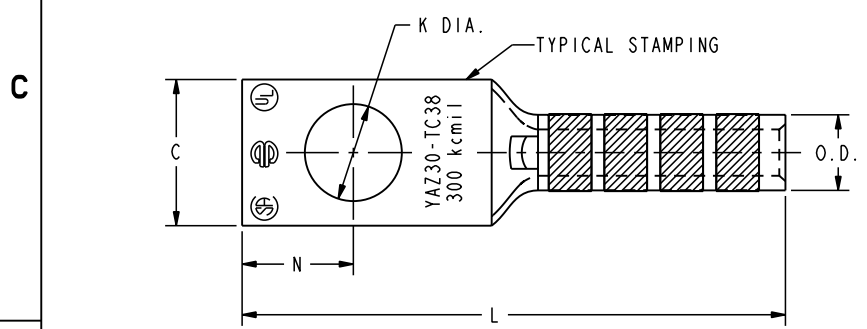

FIG. 1

FIG. 2

FIG. 3

NOTES:

- MATERIAL: COPPER TUBING.
- FINISH: TIN PLATED
- CATALOG # PT6515 ADAPTOR IS REQUIRED TO USE "U" DIES IN Y45 SERIES TOOLS.
- CATALOG # PUADP-1 ADAPTOR IS REQUIRED TO USE "U" DIES IN Y46 SERIES TOOLS.
- NAVY CABLE SIZE MAY BE OMITTED ON SOME SIZES BECAUSE OF SPACE LIMITATIONS.
- DIMENSIONS, METRIC WIRE, & METRIC BOLT SIZES IN BRACKETS [ ] ARE IN MILLIMETERS. DIMENSIONS ARE ROUNDED OFF TO THE NEAREST MILLIMETER, UNLESS OTHERWISE NOTED, AND ARE FOR REFERENCE ONLY.
- FOR USE BY CUSTOMERS THAT HAVE THIS HYPRESS™. NO NEW Y34A HYPRESS™ TOOLS ARE BEING PROCESSED.

TO ORDER BURNDY® PRODUCTS CALL		HYLUG™ (ONE HOLE CODE)	
UNITED STATES 1-800-346-4175 (LONDONDERRY, NH)		ITEM NO: NA	CAT. NO: YAZ30-TC- (TABLE)
CANADA: 1-800-361-6975 (QUEBEC) 1-800-387-6487 (ALL OTHER PROVINCES)		DRAWN BY: D.BOISVERT 02/03/2000	CHECKER: K.MCCARTHY 04/05/2000
FOR PRODUCT INFO: <a href="http://www.burndy.com">http://www.burndy.com</a>		DSN APPVL: J.MICHAUD 05/04/2000	MFG APPVL: N/A
		QA APPVL: S.BROWN	MKT APPVL: N/A
		SCALE: NTS	
		PROJ #:	SIZE
		DOCUMENT TYPE: Sales	SE212356
		REL LEVEL: Released	D SHEET 22 OF 40

REV: PE0200